

# Part II: Antenna Enhancements

## Jamming Protection of GPS Receivers

Steve Rounds, Interstate Electronics Corporation

THIS MONTH'S COLUMN features the second installment of a two-part article on jamming protection for GPS receivers. In Part I, we looked at enhancements to receiver design – primarily by integrating the GPS sensor with an inertial measuring unit. In this month's column, we examine a variety of antenna enhancements. — R.B.L.

**J**amming suppression techniques can be separated into enhancements to the receiver itself, and enhancements to the antenna providing inputs to the receiver. Part I of this article discussed receiver enhancements. We now turn to antenna enhancements.

Antenna enhancements are attractive in that they can often be applied to an existing GPS installation by upgrading only the antenna. By serving as an appliqué or simple “add on,” users are saved the cost of integrating a different receiver into their system.

Antenna enhancements can be further broken down into analog and digital implementations. The analog implementations involve mixing the radio frequency (RF) signals from multiple antennas into a single weighted signal, which is then digitized and used by the receiver digital section. As the term implies, digital implementations first digitize the RF signals using an analog-to-digital (A/D) converter, then perform the signal processing in the digital domain.

### Basic Antenna Enhancements

**Figure 1** shows block diagrams of several popular techniques for antenna enhancements, presented in such a way to highlight the differences as the complexity increases.

**Cancellers.** One of the simplest and easiest to understand antenna enhancements is the canceller. As shown in **Figure 1A**, the canceller uses two antenna inputs. The premise of the canceller is that one antenna has visibility to the jammer, but poor (or no) visibility to the composite GPS signal; the second antenna has visibility to both.

An example of such an installation could be an aircraft with an antenna on the top surface of the fuselage with its boresight nominally pointing in the zenith direction and another on the lower surface, pointing to the ground. The jammer has sufficient power to reach both antennas, but the GPS signal is only visible to the upper antenna.

For this system, if the gain (amplitude) and phase of the output of the jammer-only antenna is adjusted with a complex (gain and phase) weight,  $W$ , to be equal and opposite to the output of the jammer-plus-signal antenna, when added together, the jammer will cancel out. This is possible only because the GPS signal is well below the noise floor of the antenna, and would not affect the determination of  $W$ . The calculation of the value of  $W$  can be performed in analog circuitry that varies  $W$  to minimize the power at the summer output.

Cancellers also can prove very effective when the jamming comes from a local transmitter. Consider an application where a signal (e.g., a communications signal) is being transmitted from the same location as the GPS receiver, such as an integrated GPS/communications link. In this case, called co-site cancellation, a second antenna is not required since an accurate sample of the jammer-only signal is available from the transmitter itself. Co-site cancellers also can eliminate the effects of spurious signals generated within the GPS receiver RF section itself.

Cancellers are most effective against a single jammer source (although they also have proven effective in providing bands of protection such as against an array of

ground-based jammers viewed from the air). Multiple jammers would provide different signatures to the two antennas, measured as gain variations and time-of-arrival variations. However, the complex weights appropriate for one jammer are not generally appropriate for the second jammer, since the gain and time-of-arrival variations are generally different when the jamming signals emanate from two different locations. To circumvent this limitation, some approaches utilize multiple channel cancellers that are able to mitigate the effects of more than one jammer. However, the complexity of these designs increases rapidly with the number of channels.

**Polarimeters.** Another two-channel implementation of antenna enhancement is the polarimeter (see **Figure 1B**). Here, a single antenna output is fed through two output feed elements to generate two output channels with different polarizations, typically right-hand circularly polarized and left-hand circularly polarized. These two elements will observe the jammer differently, providing a signal difference that can be exploited to eliminate the jammer effects. As with the canceller, the trick is to calculate the two complex weights,  $W_1$  and  $W_2$ , which minimize the jammer power. Again, it is convenient to define  $W_1=1$  as was done implicitly for the canceller, simplifying the problem to the determination of a single weight.

As with the canceller, polarimeters are most effective against a single jammer, although for specific geometries they can be effective against multiple jammers.

**Spectral Filters.** **Figure 1C** shows a block diagram of a spectral filter, with  $m$  spectral taps. Such a device is also called a temporal filter, a notch filter, or in some implementations an adaptive transversal filter. Although shown in the time domain for comparison with subsequent implementations, this filter is often most easily visualized in the frequency domain.

We consider a CW jammer (see sidebar on jammer types). If the antenna output is converted to the frequency domain by passing it through a fast Fourier transform (FFT), the output will be a white-noise-like floor with a single large spike at the jammer's frequency. This is the common picture that would be seen if looking at the jammer signal on a spectrum analyzer. In a digital implementation, it is trivial to reduce the gain on the frequency bin (or bins) that correspond to this spike in order to "whiten" the output in the frequency domain. After notching out this spike, an inverse transform is applied to return the output signal to the time domain.

Unlike previous implementations with multiple taps, the spectral filter can remove multiple jammers. In the frequency domain, this corresponds to reducing the gain on several frequency bins. However, each time the gain on a frequency bin is reduced, the gain on the GPS signal content in that bin is correspondingly reduced. Therefore, while the spectral filter can mitigate the effects of more than one jammer, too many jammers can overwhelm this filter. The number of jammers that can be effectively eliminated is determined by the number and spacing of the individual temporal taps/frequency bins.

Whereas the spectral filter can reduce the effects of multiple jammers, it is completely ineffective against broadband jammers. Thinking again in the frequency domain, a broadband jammer does not appear as a single spike, but is spread over the entire GPS spectrum. With no spikes to notch out, the spectral filter is of no use.

**Spatial Nulling.** Spatial nulling is one of the most effective forms to mitigate the effects of GPS jamming, but it comes with the attendant cost and complexity. Figure 1D shows an implementation of a spatial nuller using a multi-element antenna.

To more fully understand this important technique, consider Figure 2 which shows a diagram of a simple 2-channel spatial nuller with a single GPS signal and a single jammer. The outputs of antenna elements 1 and 2,  $A_1$  and  $A_2$ , can be written as in Equation 1, where  $G_1$  and  $G_2$  represent the different gains of the two channels,  $v_1$  and  $v_2$  are the independent noise values on those

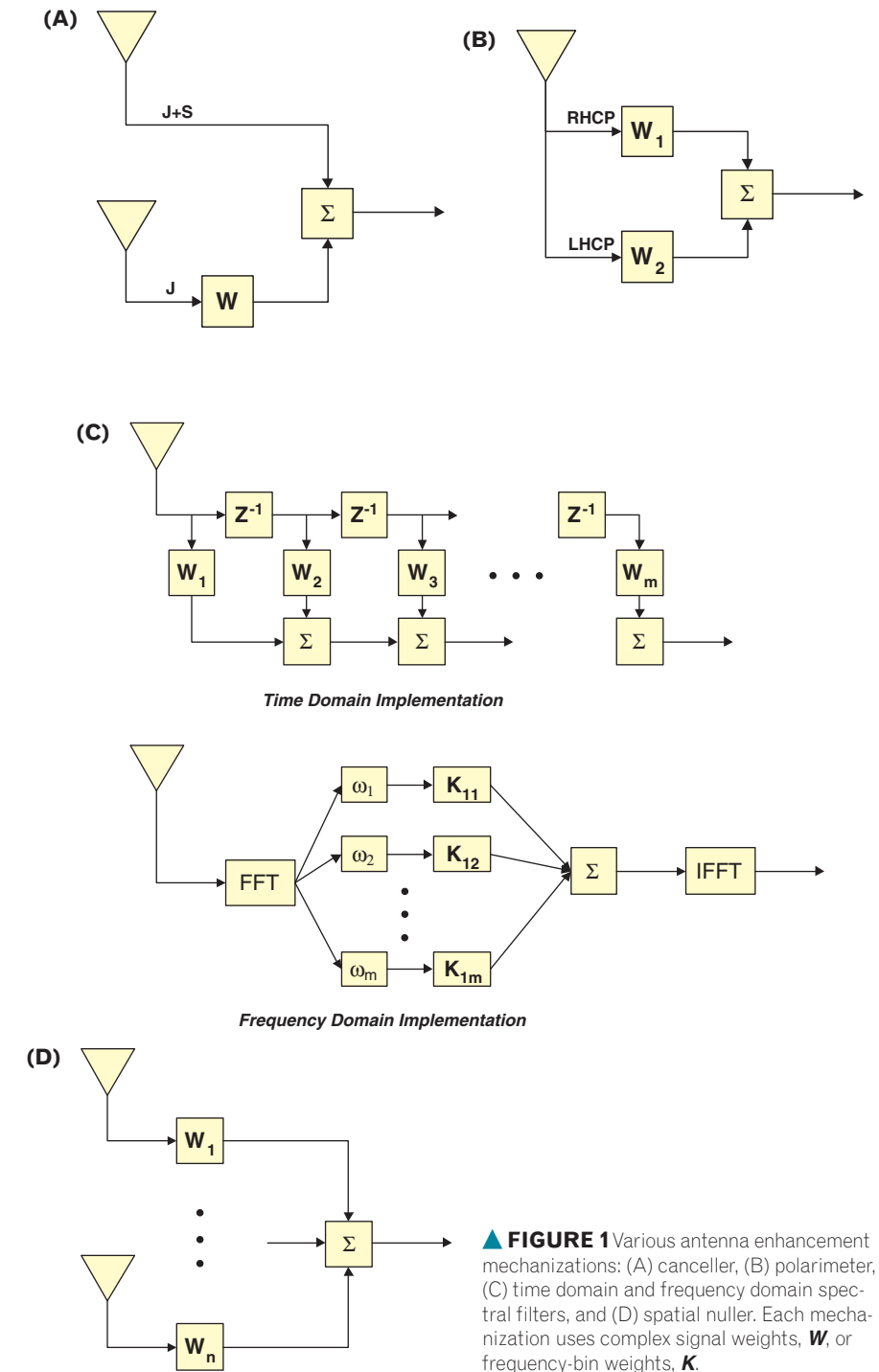

▲ FIGURE 1 Various antenna enhancement mechanisms: (A) canceller, (B) polarimeter, (C) time domain and frequency domain spectral filters, and (D) spatial nuller. Each mechanization uses complex signal weights,  $W$ , or frequency-bin weights,  $K$ .

same two channels, and the effects of antenna gain variations have not been considered.  $S(t)$  and  $J(t)$  represent the GPS and jammer signals,  $D$  is the distance between the antennas, and  $\theta_1$  and  $\theta_2$  are the elevation angles of the GPS satellite and jammer. Parameters  $c$  and  $\omega$  are the speed of light

and the GPS signal angular frequency. If we choose  $W_1=1$  and optimize the value of  $W_2$ , the spatial nuller output,  $W_1 A_1 + W_2 A_2$  can be written as Equation 2.

Examining this equation, we see that the choice of  $W_2$  has caused the jammer to vanish, while both the signal and noise have

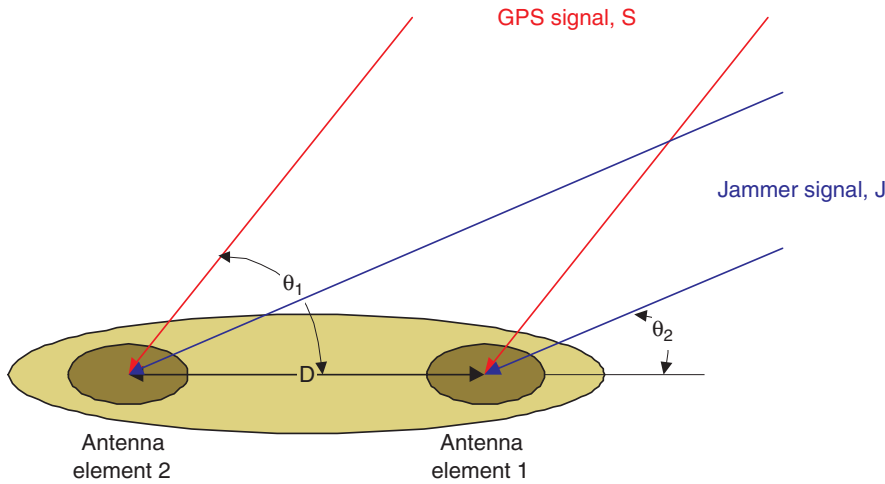

▶ **FIGURE 2** Simplified geometry for 2-element antenna used for spatially nulling a jammer

larger and larger antenna arrays.

The equations above imply that the jammer can be completely eliminated, but of course there are limitations in the real-world implementation. These limitations include the antenna size effects (related to the approximation in the first equation), loss of accuracy in the A/D conversion, and latency effects. This last category arises from typical implementations that sample the jamming environment in one cycle, calculate the weights, and apply the weights in the subsequent cycle. Changes in the jamming environment, such as caused by pulsed jammers, can reduce the algorithm effectiveness. Nonetheless, spatial nulling typically provides 25–40 dB of jamming suppression against all jammer types.

The effectiveness of the spatial nuller is often presented in an antenna gain chart, such as shown in **Figure 3**. This standard azimuth/elevation-angle chart, with the antenna zenith at the center of the circle and the horizon around the perimeter, shows results for a seven-element antenna system with five broadband jammers. The locations of the jammers and satellites are identified, and the colors represent the effect of the idealized weights in nulling the jamming for each direction in space. Notice the deep and narrow nulls that surround the jammers (represented in brown), with very little loss in effective antenna gain in the direction of the satellites.

**STAP**

What if you could combine the power of the spatial nuller against all jammer types with the relatively inexpensive ability of the temporal filters to eliminate large numbers of CW jammers? The resulting technique, called spatial temporal adaptive processing (STAP), is generally recognized as the most powerful technique for jamming suppression. **Figure 4** shows a block diagram of such a technique. By comparing this figure with the Figures 1C and 1D, we see that STAP can be thought of conceptually as the optimal combination of spatial and temporal processing with *n* antennas and *m* spectral taps. Calculating all *n* × *m* weights in parallel is critical in the implementation. This allows use of the temporal taps to attack the CW jammers, reserving the spatial capa-

$$A_1(t) = G_1 [S(t) + J(t) + v_1]$$

$$A_2(t) = G_2 \left[ S(t - \frac{D \cos(\theta_1)}{c}) + J(t - \frac{D \cos(\theta_2)}{c}) + v_2 \right]$$

$$\approx G_2 \left[ S(t) e^{\frac{-i\omega D \cos(\theta_1)}{c}} + J(t) e^{\frac{-i\omega D \cos(\theta_2)}{c}} + v_2 \right]$$

▲ **EQUATION 1**

$$W_2 = -\frac{G_1}{G_2} e^{\frac{i\omega D \cos(\theta_2)}{c}}$$

$$W_1 A_1 + W_2 A_2 = G_1 \left\{ S(t) \left[ 1 - e^{\frac{-i\omega D (\cos(\theta_1) - \cos(\theta_2))}{c}} \right] + v_1 - v_2 e^{\frac{i\omega D \cos(\theta_2)}{c}} \right\}$$

▲ **EQUATION 2**

been modified — possibly increased, possibly decreased. An important observation is that if  $\theta_2 = \theta_1$ , the GPS signal also vanishes. In physical terms, this means that if the jamming signal comes from the same direction as the satellite, the spatial nuller will inadvertently but unavoidably null the satellite as well. As a corollary, the same weights are equally effective (in an average sense) for all satellites.

If there were a second jammer from a different direction, no value of  $W_1$  and  $W_2$  would null both jammers (except the trivial case of  $W_1 = W_2 = 0$ , which also nulls all satellites). However, were a third antenna element added, a solution could be found. This points out a fundamental property of spatial nullers: an *n*-channel spatial nuller

can null *n* - 1 jammers.

With the exception of the very accurate approximation of the first equation (that is, the phase delay of the jammer signals across the antenna elements is frequency-independent), spatial nullers are equally adept at nulling broadband and CW jammers.

In the above two-element example, it

was easy to identify the value of  $W_2$  to null the jammer. However, in practice the coefficients of the individual channel equations are not known, and the complexity increases for increasing numbers of elements. There are multiple approaches for solving these equations, but with the increasing capability of modern processors, current applications trend from analog solutions toward digital solutions. Even here, multiple approaches can solve the more general equation set, including least mean square, recursive least squares, and sample matrix inversion techniques. Each of these computational algorithms has its advantages and disadvantages, particularly with regard to throughput requirements and the resultant latency of the weights, and scalability to

bilities to attack the broadband (and other) jammers.

Of course, if all  $n \times m$  weights must be calculated in parallel, this implies matrices of the order  $n \times m$  by  $n \times m$ , and these matrices must be multiplied and inverted. For  $n = 7$  and  $m = 15$ , for example, this would imply inverting a  $105 \times 105$  matrix. As with the deep integration processing discussed in last month's installment, the trick in implementing STAP is identifying simplifications in the algorithms that bring the processing requirements within reason, while retaining performance as close to optimal as possible.

Figure 5 provides an example of the advantages of STAP processing compared to spatial nulling alone. Both systems use a 7-element antenna and the STAP system also includes 7 temporal taps. The jamming scenarios for each case are identical — the same 5 broadband jammers used in Figure 3, with 5 additional CW jammers. As can be seen from the figure, the spatial nuller is overloaded — it has more jammers than its  $n - 1$  degrees of freedom. This is evident from the larger areas of deep nulls. The STAP system, however, is not overloaded, as the 5 CW jammers are handled by the temporal taps, leaving 7 spatial elements to attack the 5 broadband jammers. The STAP system shows sharp nulls around the jammers, while the nulls from the spatial nuller are broad and not as deep.

**SFAP**

Just as the temporal nuller could be visualized and implemented in either the time or the frequency domain, so the STAP process can be alternatively implemented in the frequency domain — a technique known as space frequency adaptive processing (SFAP), shown in Figure 6.

Whereas frequency-domain implementations are often more efficient than the corresponding time-domain implementations, even this simplification often does not reduce the processing requirements sufficiently. However, the SFAP implementation does offer an approximation that can substantially reduce these requirements. Considering a

single frequency bin in Figure 6, the weights can be calculated for the  $n$  different antenna elements without considering the other  $j - 1$  frequency bins, and the process repeated for each bin. Since the matrix operations tend to go as the cube of the matrix dimensions, this reduces the order of the computations from  $(j \times n)^3$  to  $j \times n^3$ . This approximation does come at the expense of some performance degradation, though often of small magnitude. This can be offset by increasing the number of temporal taps ( $j$ ) for SFAP versus the number ( $m$ ) for STAP. With this adjustment, SFAP can be more effective against large numbers of CW jammers, while minimizing the performance degradations elsewhere.

Figure 7 continues the comparison of the STAP system ( $n = 7, m = 7$ ) of Figure 5, this time with SFAP ( $n = 7, j = 128$ ) against the same 5 broadband and 5 CW jammers. As seen from this figure, the STAP and SFAP performances are very similar.

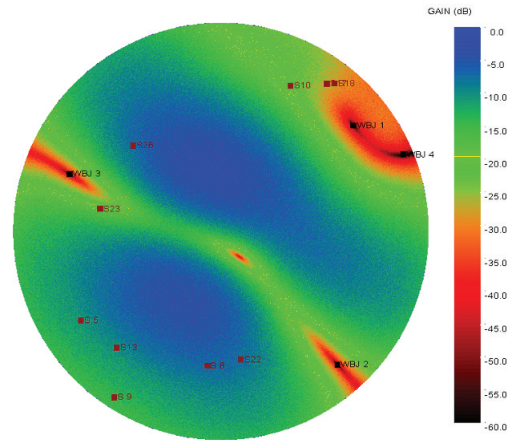

▲ FIGURE 3 Antenna gain chart example of spatial nulling (7-element antenna with 5 broadband jammers)

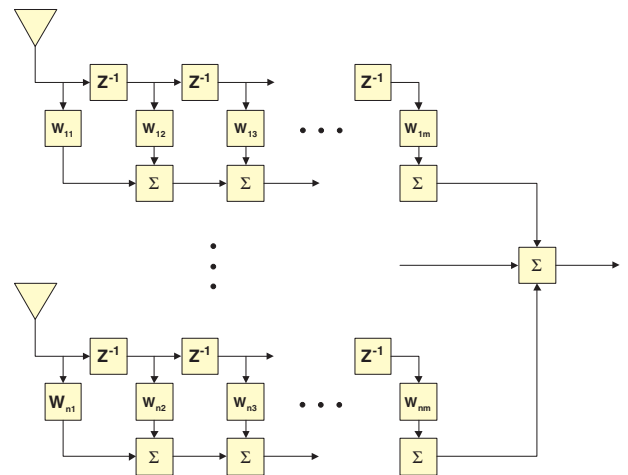

▲ FIGURE 4 Spatial temporal adaptive processing. This technique is a combination of spatial nulling with the time domain implementation of spectral filtering.

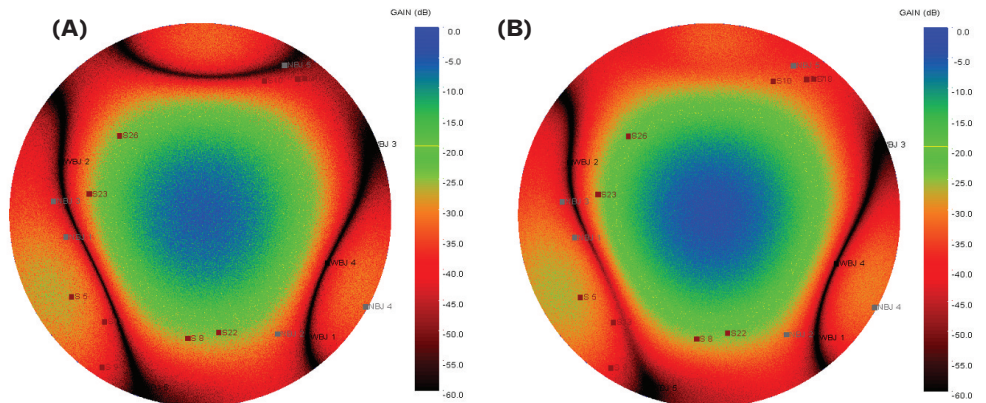

▲ FIGURE 5 Antenna gain charts comparing (A) spatial nulling with (B) spatial temporal adaptive processing

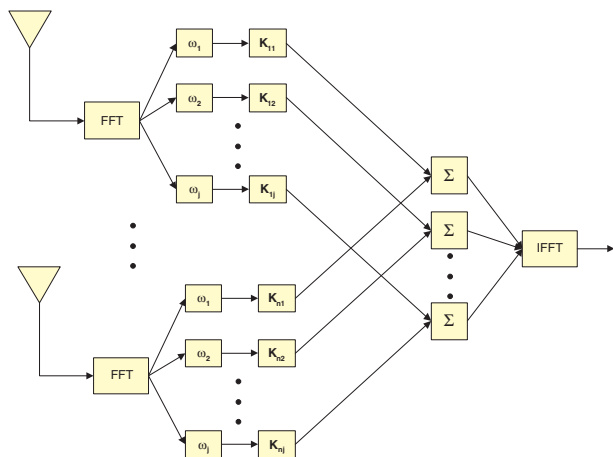

**FIGURE 6** Spatial frequency adaptive processing. This technique is a combination of spatial nulling with the frequency domain implementation of spectral filtering.

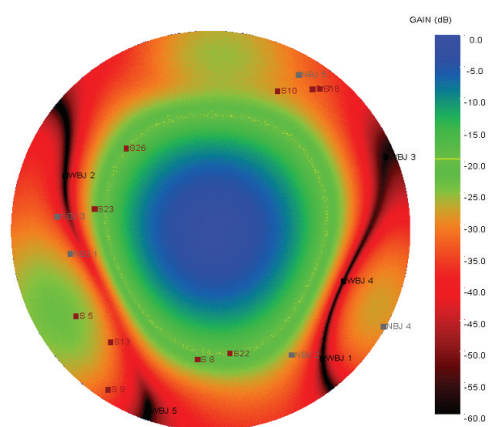

**FIGURE 7** Antenna gain chart illustrating spatial frequency adaptive processing (compare with Figure 5)

### STAP, SFAP Added Benefits

While STAP and SFAP are generally recognized to be the most powerful methods to minimize the effects of jammers, these techniques have additional benefits.

**Beamforming.** Beamforming can be thought of as the inverse of spatial nulling: instead of minimizing the gain in the direction of the jammer, beamformers maximize the gain in the direction of a satellite. This technique is most effective when the antenna array is not fully loaded, that is, the number of jammers is less than the maximum of  $n-1$ .

Unlike nulling, however, beamforming cannot observe the satellite signal and adaptively maximize the antenna gain in that direction since the satellite signal is below the

noise floor and not observable. (A small number of implementations calculate the weights after correlation with the satellite code, and therefore the satellite signal has been restored to be above the noise floor. As with most tradeoffs, this ability comes at some expense, in this case substantially increased hardware requirements.) Therefore, the beamforming algorithms must be provided with the known azimuth and elevation angle of the satellite, transformed to the antenna coordinate system.

When examined through the detailed mathematics of calculating the complex weights, beamforming represents a straightforward additional operation of multiplying by a steering vector to the satellite.

Since the direction to each satellite is different, the process must be repeated for each satellite. This means that the weights applied to the antenna outputs,  $W_{ij}$  in Figure 4, are different for each satellite. Correspondingly, there are multiple outputs of the beamforming/STAP system, each optimized for a distinct satellite. If a receiver has only four input channels, a beamforming/STAP system might develop three outputs optimized for three distinct satellites, with the fourth channel optimized to maximize the overhead gain.

In typical applications, beamforming can increase the strength of the received satellite signal by about 3–6 dB. Note also that since this technique makes use of the spatial properties of the STAP and SFAP process, it is equally effective with a spatial nuller.

**Self-Equalization.** One of the real-world issues that limit the effectiveness of spatial nulling is the need to match the RF channels for each antenna element. Gain mismatches, phase delay mismatches, and bandwidth mismatches all limit the ultimate

system performance. One of the strengths of STAP and SFAP is that the temporal taps can substantially reduce the sensitivity to these errors. While it is difficult to quantify the sensitivity of the various algorithms to these effects, degradations in threshold performance of 7–15 dB are not uncommon for poorly matched spatial nulling systems, while these same effects are greatly reduced for STAP and SFAP systems.

Spatial nullers circumvent this limitation by utilizing high precision RF components, or by performing calibration and compensation of the RF characteristics. While this has proven feasible, utilizing the temporal taps of the STAP/SFAP algorithms to minimize the effects provides a much more cost-effective solution.

**Other Benefits.** Just as multipath can cause problems with precision tracking of the satellite signals, multipath can cause a single-jammer signal to arrive from multiple directions with different delays. In a spatial nuller, this appears to the nulling algorithms as two distinct jammers, and therefore consumes two of the “ $n-1$ ” degrees of freedom from the antenna array. For a STAP/SFAP implementation, because the temporal weights are optimized in combination with the spatial weights, the multipath jammer signal can be recognized as a time delay of the direct jammer signal.

Another benefit of STAP/SFAP and spatial nulling, when implemented in a digital design, is the ability to locate the jamming sources. As shown in Figure 2, the weights are a function of the angle of arrival of the jammer. Once the weights have been calculated, it is possible to invert the equations to determine the angle of arrival of the jammers that are being nulled. The derived angles represent the azimuth and elevation angle of the jammer in antenna coordinates, which typically must then be rotated to Earth-fixed coordinates to identify the jammer location. One such implementation is the Multiple Signal Classification (MUSIC) algorithm, developed at Stanford University. The effectiveness of algorithms such as these depends strongly on the antenna geometry.

### Receiver Impacts

Antenna enhancements, even when imple-

mented as an appliqué, are not completely transparent to the receiver. Two important issues are phase perturbations and RF dynamic range.

**Phase Perturbations.** Most of the techniques discussed include multiplying the output of the antenna elements by complex weights in order to null the jammer(s). Furthermore, these weights change continuously as the antenna rotates and the jammer waveform is otherwise modified. Since the weights are complex, this implies that time-varying phase changes will be applied to the signal provided to the GPS receiver for tracking.

Inside the GPS receiver, the Costas loop tracks the phase of the GPS signal, using the measurements for high accuracy positioning (in real-time kinematic applications) or for delta pseudorange observations to improve velocity performance. Phase modifications introduced by the nulling algorithms will be erroneously interpreted as phase changes of the GPS signal. Some implementations go so far as to avoid nulling until

the jammer level reaches a threshold, and then discontinuing phase tracking for higher jamming levels.

In a digital implementation of the nulling, the weights and therefore the applied phase perturbations are known. In theory, these can be compensated, although issues of latency become important. Additionally, the phase compensations are unique for each satellite being tracked.

**RF Dynamic Range.** Because of the very high performance capabilities of some antenna enhancement techniques, often the RF front end ultimately determines the limit of system performance. For the nulling algorithms to work, the RF channels must remain linear at the peak jamming levels. In fact, for the receiver to continue to work effectively against most waveforms, the RF linearity must extend to >12 dB above the average jamming levels. With the capabilities afforded by deep integration and STAP/SFAP, this implies linearity of the RF front end to exceedingly high input power levels. This in turn becomes a major driver

in system power, size, and cost.

**Conclusions**

Jamming of GPS receivers is real. The susceptibility to GPS jammers is very high, due both to the very weak GPS signal and the sensitivity of the short C/A-code to CW interference. Unintentional jamming has been observed in civilian applications. Military forces that depend on GPS are rapidly trying to develop protection for their receivers from known, intentional jamming threats. Industry is responding with a wide variety of schemes for jamming protection, as outlined in this article, with each technique having its particular strengths and weaknesses.

**Acknowledgments**

The author would like to thank his many colleagues in government and industry for their contributions to the development and understanding of the many topics in this article, particularly his current colleagues at IEC. 🌐

**JAMMERS**

Any transmitter whose fundamental frequency or radiated harmonics are within the L1 or L2 frequency bands has the potential to interfere with or jam the GPS signal. Military forces use purpose-built jamming transmitters, or jammers for short, as weapons in electronic warfare to deny an adversary the use of the radio spectrum whether it be used for communications, radar, or navigation.

A jammer is typically characterized by its signal spectrum – its carrier and how it is modulated. The basic jammer types are CW, white-noise, pulsed, and FM.

**CW.** A continuous wave (CW) jammer transmits a continuous unmodulated carrier. If the CW jamming signal has the same frequency as the “target” signal but is not in phase with it, the jamming is non-coherent. If the jamming signal is in phase with the target, the jamming is coherent. It is also possible to sweep the CW jamming signal over a range of frequencies centered on the target signal’s frequency (SCW). For example, every mil-

lisecond the jammer frequency could be swept linearly from 50 kHz below the target frequency to 50 kHz above it and back again.

**White-noise.** For jamming purposes, the phase of a carrier can be randomly varied to create a white-noise jammer. (White noise has a Gaussian voltage distribution with a zero mean and a uniform phase distribution between 0 and  $2\pi$  and essentially contains the contributions of a wide band of frequencies akin to how white light is composed of a wide band of colors.) The rapidity with which the phase changes are made will determine the bandwidth of the jammer. If the bandwidth were 20 MHz, for example, the jamming signal would essentially overlay the whole GPS signal. This type of jammer is also known as a wideband or broadband jammer. In a variation on the white-noise jammer, the carrier is modulated by a pseudorandom noise code. The resulting wideband signal has a structure similar to that of a GPS signal and, in fact, the code sequence and chipping rate can be

selected to match one of the GPS signals. Such a jammer can be quite effective.

**Pulsed.** Interrupting a continuous wave by periodically keying the transmitter on and off produces a sequence of pulses. The pulsing might be regular with a duty cycle of say 50 percent (as generated by a square-wave sequence) or random with varying pulse width. Radars are pulsed transmitters with very short regular duty cycles. A pulsed signal is a basic form of amplitude modulation (AM).

**FM.** In a frequency-modulated (FM) signal, the instantaneous carrier frequency changes with the frequency and amplitude of a modulating waveform. The transmitted bandwidth is governed by the ratio between the frequency deviation (how much the instantaneous frequency departs from the carrier frequency) and the modulating frequency. An FM jamming signal might use a pure sinusoidal modulating waveform with a frequency of 1 kHz and with a frequency deviation of  $\pm 50$  kHz. – R.B.L.

---

**Steve Rounds** is a senior director in the Advanced Technology Department at Interstate Electronics Corporation (IEC), a division of L-3 Communications, in Anaheim, California. In addition to his support of antijamming development, he is responsible for the identification and integration of new technologies at IEC. He holds a B.S. degree in physics from Stevens Institute of Technology in Hoboken, New Jersey, and an M.S. degree from Yale University in New Haven, Connecticut.



"Innovation" is a regular column featuring discussions about recent advances in GPS technology and its applications as well as the fundamentals of GPS positioning. The column is coordinated by **RICHARD LANGLEY** of the

Department of Geodesy and Geomatics Engineering at the University of New Brunswick, who appreciates receiving your comments and topic suggestions. To contact him, see the "Columnists" section on page 2 of this issue.

## Further Reading

**For general introductions to GPS and jamming as well as references for receiver antijamming enhancements, see**

Further Reading in Part I of this article, "Jamming Protection of GPS Receivers – Part I: Receiver Enhancements" by S. Rounds in *GPS World*, Vol. 15, No. 1, January 2004, pp. 54-59.

**For an introduction to antennas and how they work, see**

"A Primer on GPS Antennas" by R.B. Langley in *GPS World*, Vol. 9, No. 7, July 1998, pp. 50-54.

**For further information on adaptive antenna arrays, see**

*Adaptive Antennas: Concepts and Performance* by R.T. Compton, Jr., published by Prentice Hall, Englewood Cliffs, New Jersey, 1988.

*Introduction to Adaptive Arrays* by R.A. Monzingo and T.W. Miller, published by John Wiley & Sons, New York, New York, 1980.

"Adaptive Multisensor Detection and Estimation" by A. Steinhardt in *Adaptive Radar Detection and Estimation*, S.S. Haykin and A. Steinhardt, eds., published by John Wiley & Sons, New York, New York, 1992, pp. 91-160.

**For details of the MUSIC algorithm, see**

"Multiple Emitter Location and Signal Parameter Estimation" by R.O. Schmidt in *IEEE Transactions on Antennas and Propagation*, Vol. 34, No. 3, 1986, pp. 276-280.