

MICROWAVE PROJECTS

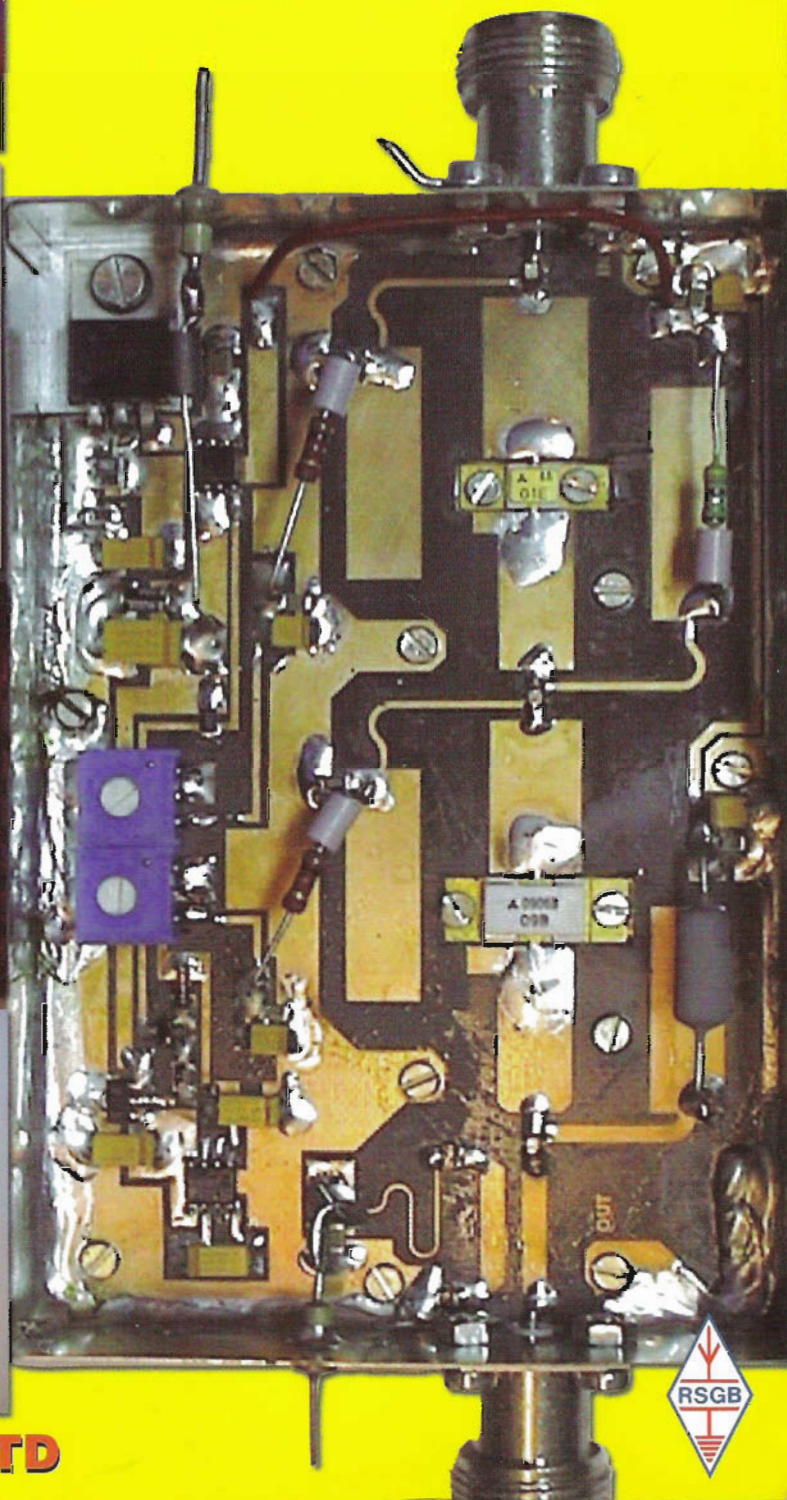

Edited by
Andy Barter, G8ATD

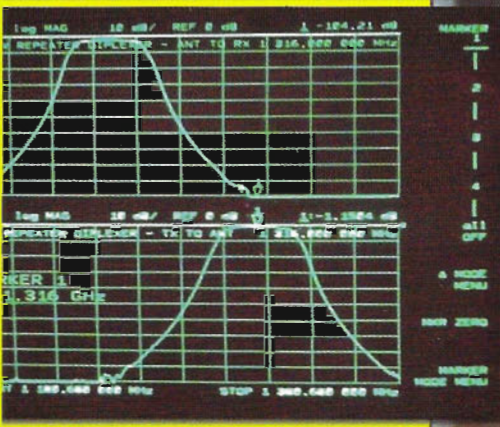

Microwave Projects

Edited by Andy Barter, G8ATD

Published by The Radio Society of Great Britain, Cranborne Road, Potters Bar, Herts, EN6 3JE.

First published 2003 reprinted 2005

© Radio Society of Great Britain, 2003. All rights reserved. No parts of this publication may be reproduced, stored in a retrieval system, or transmitted, in any form or by any means, electronic, mechanical, photocopying, recording or otherwise, without the prior written permission of the Radio Society of Great Britain.

ISBN 1-872309-90-9

Publisher's note

The opinions expressed in this book are those of the authors and not necessarily those of the RSGB. While the information presented is believed to be correct, the authors, the publisher and their agents cannot accept responsibility for the consequences arising for any inaccuracies or omissions.

Cover design: Anne McVicar

Production: Mark Allgar, M1MPA

Typography: Andy Barter, K M Publications, Luton

Cover photographs were kindly supplied by Giles Read of www.G1MFG.com

Printed in Great Britain by Latimer Trend & Company Ltd of Plymouth

Acknowledgements

The articles in this book have been supplied by radio amateurs from around the world. The editor would like to thank the following people and organisations for their contributions:

André Jamet, F9HX
Paolo Pitacco, IW3QBN
Daniel Uppström, SM6VFZ
Kerry Banke, N6IZW
Tom Mayo, N1MU
Grant Hodgson, G8UBN
Harold Fleckner, DC8UG
Ian Bennett G6TVJ
Sigurd Werner, DL 9MFV
Carsten Vieland, DJ4GC
Carl G. Lodstrom, SM6MOM
E.Chicken MBE, BSc. MSc, CEng, FIEE, G3BIK
Alexander Meier, DG6RBP
Harald Braubach, DL1GBH
Gunthard, Kraus, DG8GB
VHF Communications Magazine
UKW Berichte Magazine
San Diego Microwave Group

Finally the book would not be what it is without the help of my proof reader, Pat Brambley, who has hopefully found all of the major mistakes.

Chapter	Title	Page
1	Signal Sources	
	• 144MHz transceiver	1
	• Microtransmitter for L band	29
2	Transverters	
	• Building blocks for a 23cm transverter	37
	• 10GHz Transverter from Surplus Qualcomm OmniTracks Units	46
	• A "building block" 5750MHz transverter design	61
3	Power Amplifiers	
	• GH Quad linear amplifier for 23cm	69
	• A 10 watt power amplifier for the 13cm band using GaAs technology	78
	• A 13cm power amplifier using a GaAs MMIC	88
	• Amplifier for 47GHz using chip technology	90
4	Test Equipment	
	• A sensitive thermal power meter	97
	• A grid dip meter	105
	• A SINAD meter	112
	• A ± 10 5GHz pre divider	120
	• Made to measure directional couplers	125
	• A ± 10 10GHz prescaler using state-of-the-art ICs	134
5	Design	
	• Modern design of band pass filters made from coupled lines	143
	• Using TRL85 for synthesis and analysis of microwave problems	170
	Index	179

After editing The International Microwave Handbook in early 2002 the RSGB contacted me to ask if I could produce a book of weekend projects for the microwave enthusiast. I explained that most microwave projects were much more than just weekend projects, so the title microwave cookbook was discussed but it was thought that there may well have been many disappointed purchasers of such a title! Finally the title of Microwave Projects was chosen.

The microwave amateur radio bands still attract keen constructors who experiment with different designs and technologies to achieve that moment of joy when a rare contact or contact on a new band is made. The content of this book has been chosen to wet the appetite of these amateurs with designs from all around the world using everything from tried and tested designs, through modification of second hand equipment, to new designs using state of the art components.

I have tried to organise the various articles in a logical sequence. This starts with generating your signal with a transceiver or a synthesised transmitter, followed with a number of transverter designs. Having produced rf on the required band there are some useful amplifier designs. Of course you will need some test equipment to help persuade your new equipment to work, if like me you do not have rf "green fingers". In true amateur style if all else fails you will need to resort to the theory of how your equipment should be working, so there is a chapter with some design aids.

Andy Barter, G8ATD

Signal Sources

In this chapter :

- A 144MHz transceiver
- Microtransmitter for L band

The most popular method to operate on the microwave bands is to use a commercial transceiver followed by a transverter to change the operating frequency to the desired band. As described in the first article of this chapter the commercial equipment available nowadays often has lots of bells and whistles but lacks some of the basic characteristics that have been superseded in the name of progress. So the way forward is to make your own transceiver. This is a very big project but fortunately André Jamet has done all of the hard work.

The other technology that is used as a matter of course in commercial equipment is the Phase Locked Loop. There are also many examples of designs for the amateur constructor. With the explosion in the mobile telephone market and other consumer market communications devices, the technology required by amateurs to make the job easier is becoming more and more available. The second article of this chapter is a neat design using some of the latest devices.

A 144MHz transceiver for SHF, André Jamet F9HX

Why make things simple when you can make them complicated? (Gribouille, misunderstood philosopher)

Typical equipment for SHF operation

For operating on the 5.7, 10, 24 and 47GHz bands and beyond a transverter is usually used to reduce the signal to be received or transmitted to lower frequencies. The 144MHz band is in frequent use as an intermediate frequency up to 10GHz, but the 432MHz and 1,296MHz bands are also used for higher frequencies.

We therefore need a VHF or UHF transceiver with the characteristics required to work in combination with the transverter i.e. one that can generate SSB and telegraphy, but also has certain accessories which are very useful for SHF traffic.

One transceiver very widely used for this application on the 144MHz band is the famous IC-202. In spite of its faults:

- An imprecise frequency display
- An S-meter which is just as imprecise



Fig 1: A picture of the completed transceiver.

- No receive selectivity adjustment (to adjust the pass band to improve the signal-to-noise ratio)
- No transmit power control
- No pip generator (to make it easier to get into contact)
- Very frequently poor health

Also bear in mind the great age of those in service and the amount of travelling they have had to endure.

So among the OMs working with SHF a wish has often been expressed to replace this old companion with a more modern transceiver that performs better. Unfortunately, tests carried out using modern transceivers fitted with a very large number of accessories have not always given the results expected. If the various faults mentioned above have disappeared, a new one has seen the light of day. The spectrum purity of their local oscillator is not up to that of the older equipment! This is a hindrance to the reception of weak signals [1,2], when high amplitude signals are received, and to the generation of a narrow transmission. It may appear presumptuous to criticise these transceivers, they benefit from all of the current technology. However using PLLs and, above all, DDSs, their spectrum purity close to the carrier frequency (and also at a distance, in spite of numerous filters) does not attain that of a simple crystal oscillator, even when pulled in frequency in a VXO, as used in the IC-202.

All this is perhaps slightly exaggerated, but the 10GHz specialists (and not only in France) have a lot of trouble in replacing their IC-202s, and several have reconditioned them to give them a new lease of life, adding on the new equipment required.

F9HX

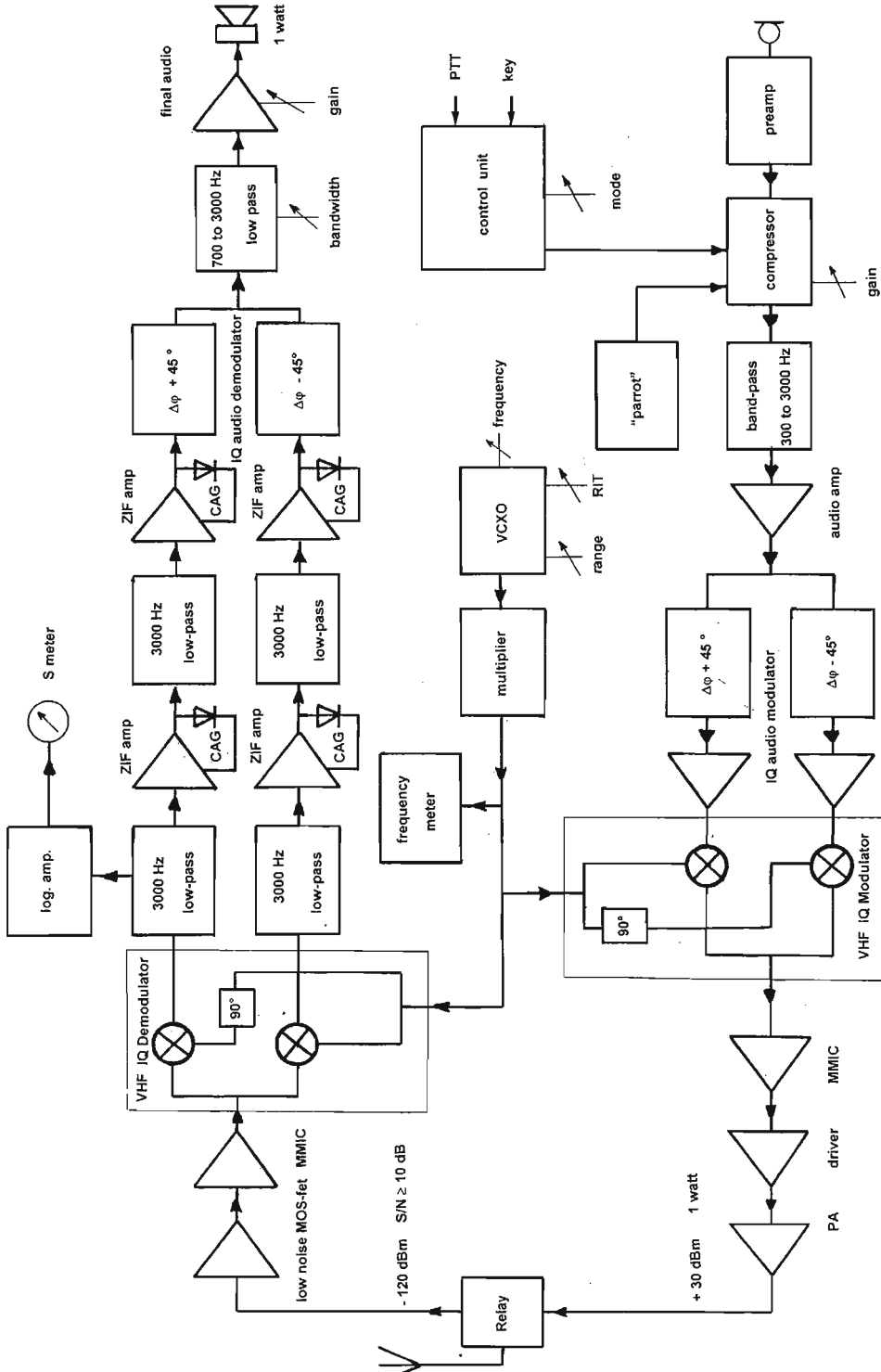

Fig 2: Block diagram of the zero intermediate frequency 144MHz transceiver.

Microwave Projects

What if we replaced our IC-202s?

That's the title of several articles which have appeared over the last two years or so in the French SHF magazine [3], written by your humble servant. The original idea was to create a 144MHz transceiver that would have precisely the characteristics required, without any unnecessary accessories. A transceiver is now functioning efficiently, and allows for 10GHz operation that gives the same results as the IC-202.

In the specifications laid down at the start, there were also plans to have three transceivers as an ideal. One used to drive the transverter as explained above, the second with an external PA supplying about fifty Watts, intended for traffic on the path being used for making contact, and the third as a back-up in case one of the other two broke down! The first and the last applications may well be possible, but the second is much less so, as we shall see below.

The transceiver principle implemented

It would have been simple to retain the IC-202 structure, i.e.:

- A simple intermediate-frequency conversion receiver operating around 10MHz, comprising a quartz filter to obtain the desired selectivity followed by a product detector for the demodulation of the CW and SSB.
- A transmitter using the same quartz filter to reject the unwanted sideband and generate SSB.

This solution was adopted by F1BUU, and has been described in articles in the amateur press [4]. But, following the precept of the philosopher mentioned in the heading, why not do things differently and perhaps in a more complicated way? After all, it is one of our tasks as radio amateurs to look for new paths in both equipment and propagation and transmission modes.

As Uncle Oscar has reminded us [5], we can also generate and demodulate SSB using the method known as phasing i.e. using phase converters to cancel the unwanted sideband. The intermediate frequency can be HF, as for the quartz filtering method, or even in the audio frequency range.

This method had been practically abandoned, but it has been taken up again for the transceivers used in mobile phones. So why not try it?

Reception is based on simple conversion i.e. a single frequency change. But, since the local oscillator is on the same frequency as the signal received, the intermediate frequency is directly in the audio range. This is referred to as being at zero intermediate frequency, since if the modulation signal is at zero frequency, the intermediate frequency is as well (and not at 10MHz). In English publications, the expression "direct conversion" refers simultaneously to the single frequency change and to the zero intermediate frequency [6,7], whereas in France some assume that direct conversion corresponds to the single frequency change, without the intermediate frequency being at zero. The block diagram of the transceiver is shown in Fig. 2.

In the receiver the antenna is matched to a low noise FET by a simple LC circuit. The output is

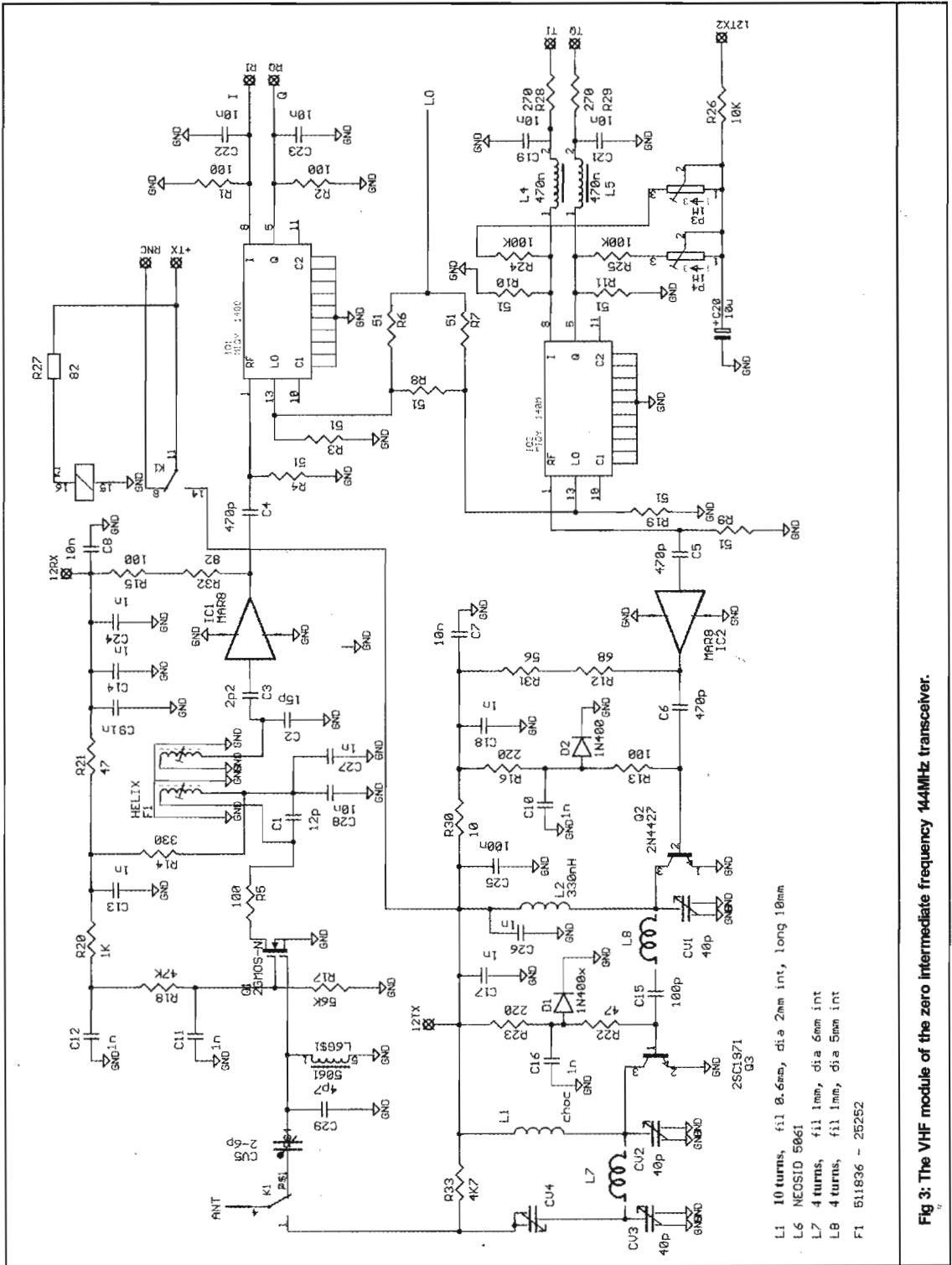

- L1 10 turns, fil 0.6mm, dia 2mm int, long 10mm
- L6 NEOSID 5061
- L7 4 turns, fil 1mm, dia 6mm int
- L8 4 turns, fil 1mm, dia 5mm int
- F1 511836 - 25252

Fig 3: The VHF module of the zero intermediate frequency 144MHz transceiver.

Microwave Projects

fed to an MMIC through a band-pass filter. This feeds a Mini Circuits double balance mixer to demodulate the signal into I and Q audio signals. These very low level audio signals (in the order of a microvolt for VHF reception in nanovolts) these are amplified by two identical channels of amplifiers fitted with automatic gain controls. They also have active low-pass and high-pass filters in order to limit the pass band received. Then the level is sufficient, the I and Q signals are phase-shifted in what are known as Hilbert filters, in such a way that, when they are subsequently added together, the signals from the wanted sideband are added and those from the other are cancelled out. An elliptic 8th order filter using a capacitor switching IC gives an adjustable bandwidth from one to three kilohertz. A one watt audio amplifier ensures a loud signal from the speaker. The demodulator is fed by the LO which comprises four VCXO's switched from the front panel and multiplied to give VHF reception. A logarithmic high dynamic range IC is used for the S-meter.

In the transmitter modulation is obtained from a microphone or a one kilohertz signal for CW, Tune or Dots. This signal is initially amplified, then rigorously filtered to allow only the band needed for SSB to pass. Two Hilbert filters produce I and Q signals to feed the double balanced modulator that produces a VHF SSB signal that only needs to be amplified up to the desired power. A voice record and playback IC stores a twenty second message for calling CQ.

This all seems complicated, and in fact it is, but not that much! For those interested in the theory, articles have been published in the amateur press [8,9] explaining mathematically the functioning of this method and also that of Weaver, which is a refinement of it. A Slovenian radio amateur [10] has described some intermediate-frequency direct conversion UHF and even SHF Weaver transceivers, up to 10GHz, which are models of application for modern techniques. Lets also recall the article published by F61WF in [11], which describes a direct conversion zero intermediate frequency decametric receiver.

Review of various functions of transceiver

To study the behaviour of the transceiver, modules were created to handle one or more related functions, each on a printed circuit. This also proved to be of interest for the final design, and the idea of a single printed circuit was set aside for the final assembly.

Starting from the antenna, we first find a 50 Ohm relay, which handles the transmit receive switching for the VHF section.

Receive section

VHF module (Fig. 3)

The VHF signal is amplified by a low noise selective stage that is fitted with a robust BF 998 dual gate FET transistor, with a performance level at least equal to that of the CF 300, which is only too well known for its fragility over voltages. A filter limits the pass band to the limits of the 2m band and feeds an untuned amplifier fitted with an MMIC. The amplified VHF signal feeds a

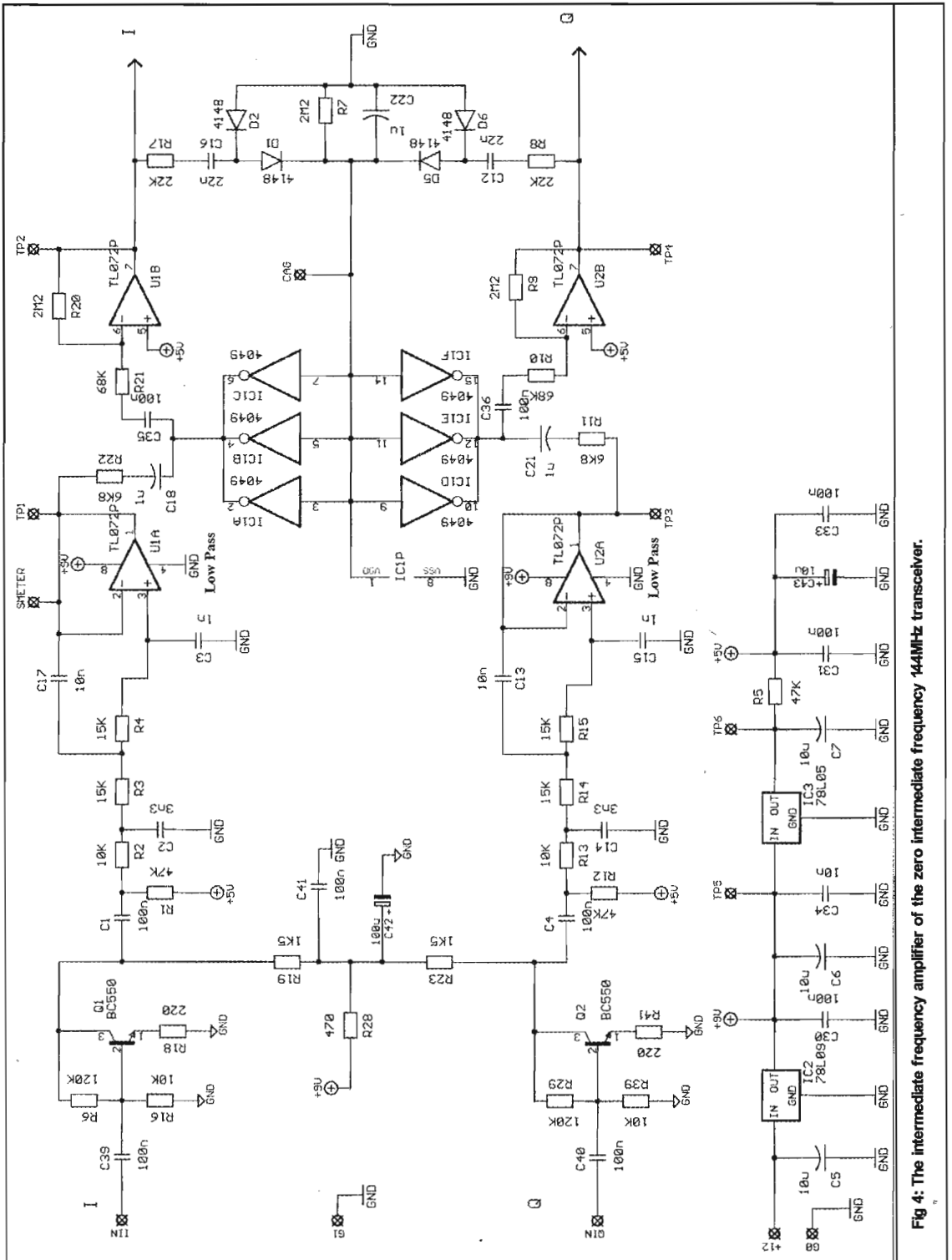

Fig 4: The intermediate frequency amplifier of the zero intermediate frequency 144MHz transceiver.

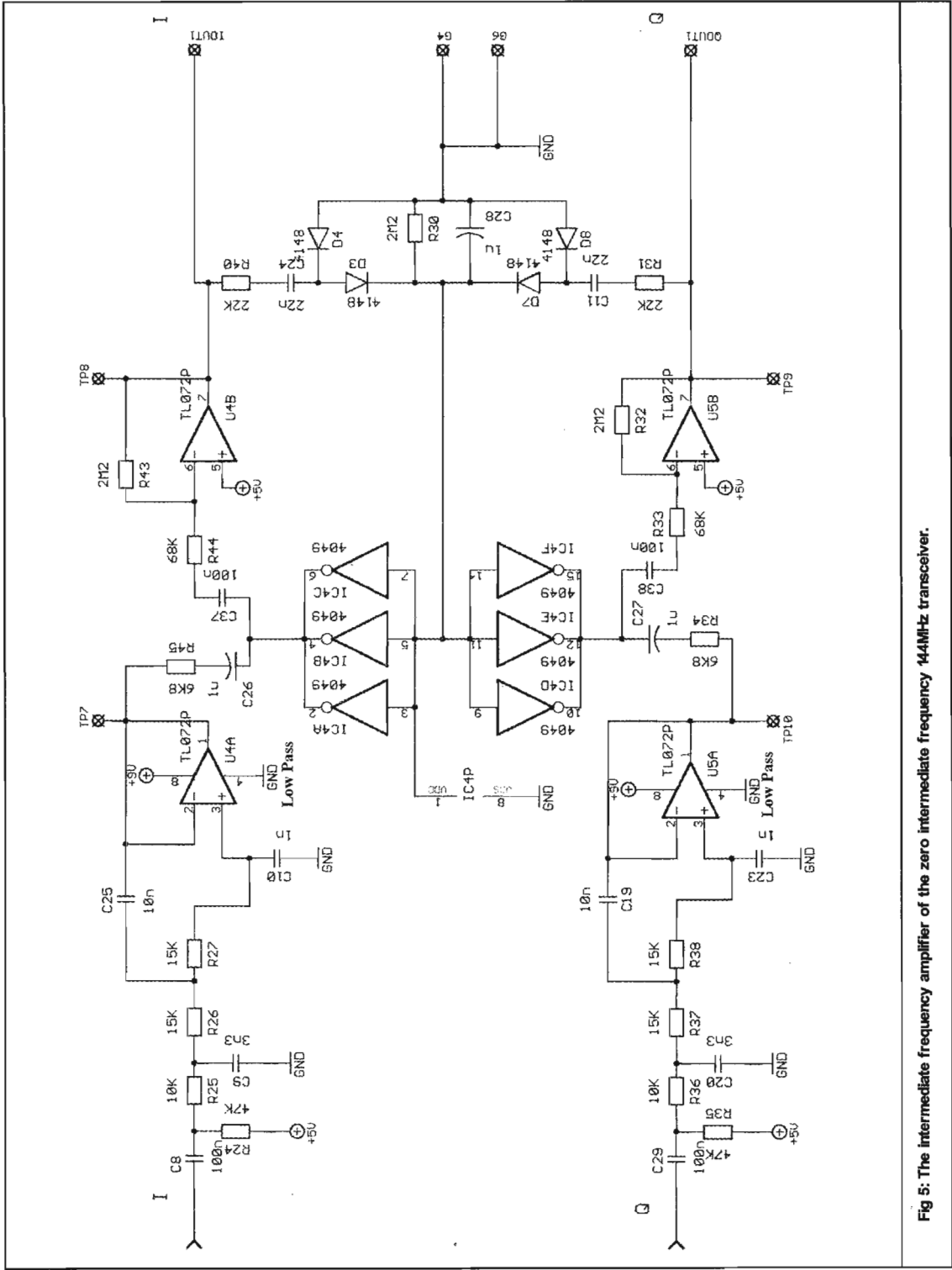

Fig 5: The intermediate frequency amplifier of the zero intermediate frequency 44MHz transceiver.

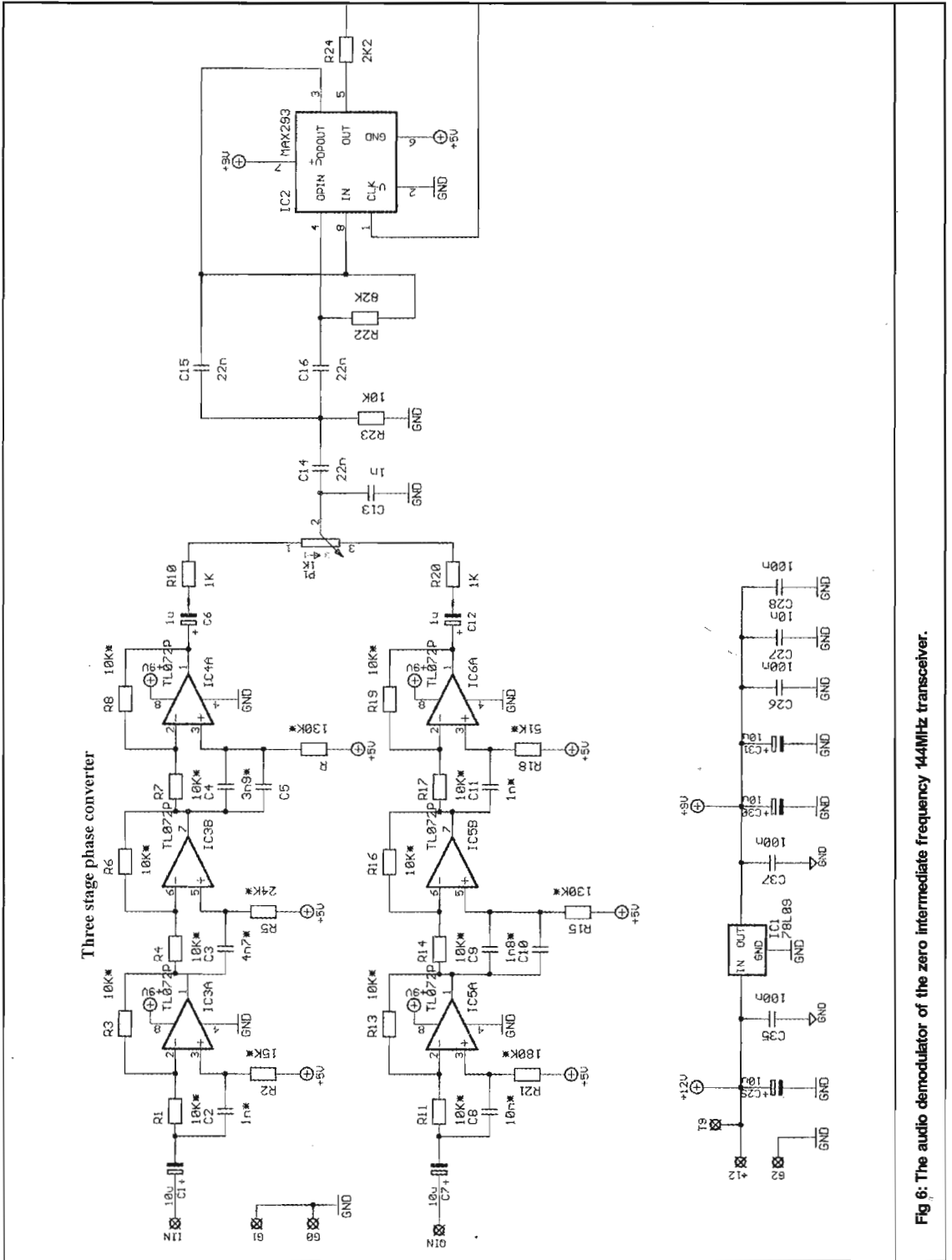

Fig 6: The audio demodulator of the zero intermediate frequency 144MHz transceiver.

Microwave Projects

Mini Circuits quadrature demodulator, which also receives the signal from the local oscillator that is described below. The output signals from the demodulator are in-phase and quadrature signals referred to as I and Q.

Intermediate frequency amplifier (Figs. 4 and 5)

The printed circuit comprises two identical amplification channels with a low noise transistor at the input of each of them, followed by a low pass filter and a variable gain amplifier acting as an automatic gain control. Next is another low pass stage and another variable gain stage. The outputs from this module are thus always two square wave audio signals, but amplified, calibrated for the pass band and amplitude compressed.

Audio demodulator (Figs. 6 and 7)

On another printed circuit, we first of all find two channels with different phase conversion. These are the Hilbert circuits that bring the signals from the desired sideband into phase and those from the other sideband into opposition. A passive circuit combines the two channels to obtain only the desired sideband. A first order active high pass filter and an eighth order elliptical low pass filter actively limit the pass band and play the major role in defining the transceiver band. A knob on the front panel can control the low pass filter. This adjusts the cut off frequency from 700 to 3,000Hz to cover the SSB and CW requirements (Fig. 20).

Finally, a power amplifier stage can feed the internal loudspeaker and/or a headset.

Transmit section

As shown in Fig. 8, the signal from the microphone, which can be ceramic, electret or magnetic, is amplified by a stage followed by an adjustable compressor. Then high pass and low pass filters, as efficient as those used in the receiver, limit the pass band to 300 to 3,000Hz. An input is provided for the signal from the parrot and 800Hz generator incorporated in the equipment, for CQ calls, CW and the generation of pips to assist when aligning parabolic antennas.

The signal is then fed to two channels, each including Hilbert phase-shift filters to generate I and Q signals (Fig. 9).

On the same printed circuit as the receiver section, we find the transmit section (Fig. 3). It receives square wave audio signals and feeds a Mini Circuits modulator, which is also fed by the signal from the local oscillator. The local oscillator is on a separate module, and is divided into two outputs by a 3dB resistive divider to feed the receive demodulators and transmit modulator. The output from the modulator is amplified by an MMIC, followed by two temperature stabilised class AB stages, each having a diode thermally linked to its casing. The output power can be adjusted using a knob located on the rear face of the transceiver by controlling the level of I and Q signals feeding modulator.

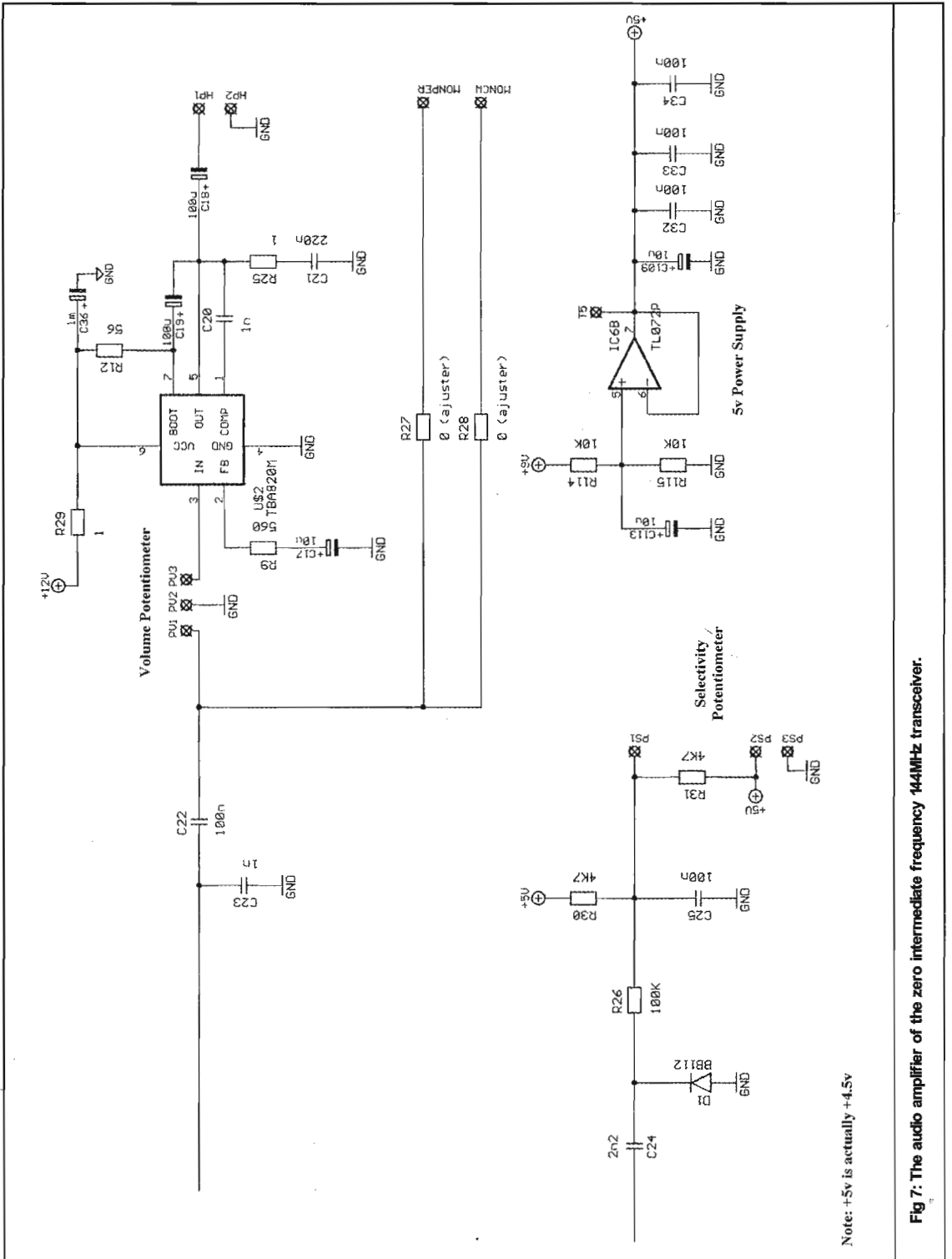

Note: +5v is actually +4.5v

Fig 7: The audio amplifier of the zero intermediate frequency 144MHz transceiver.

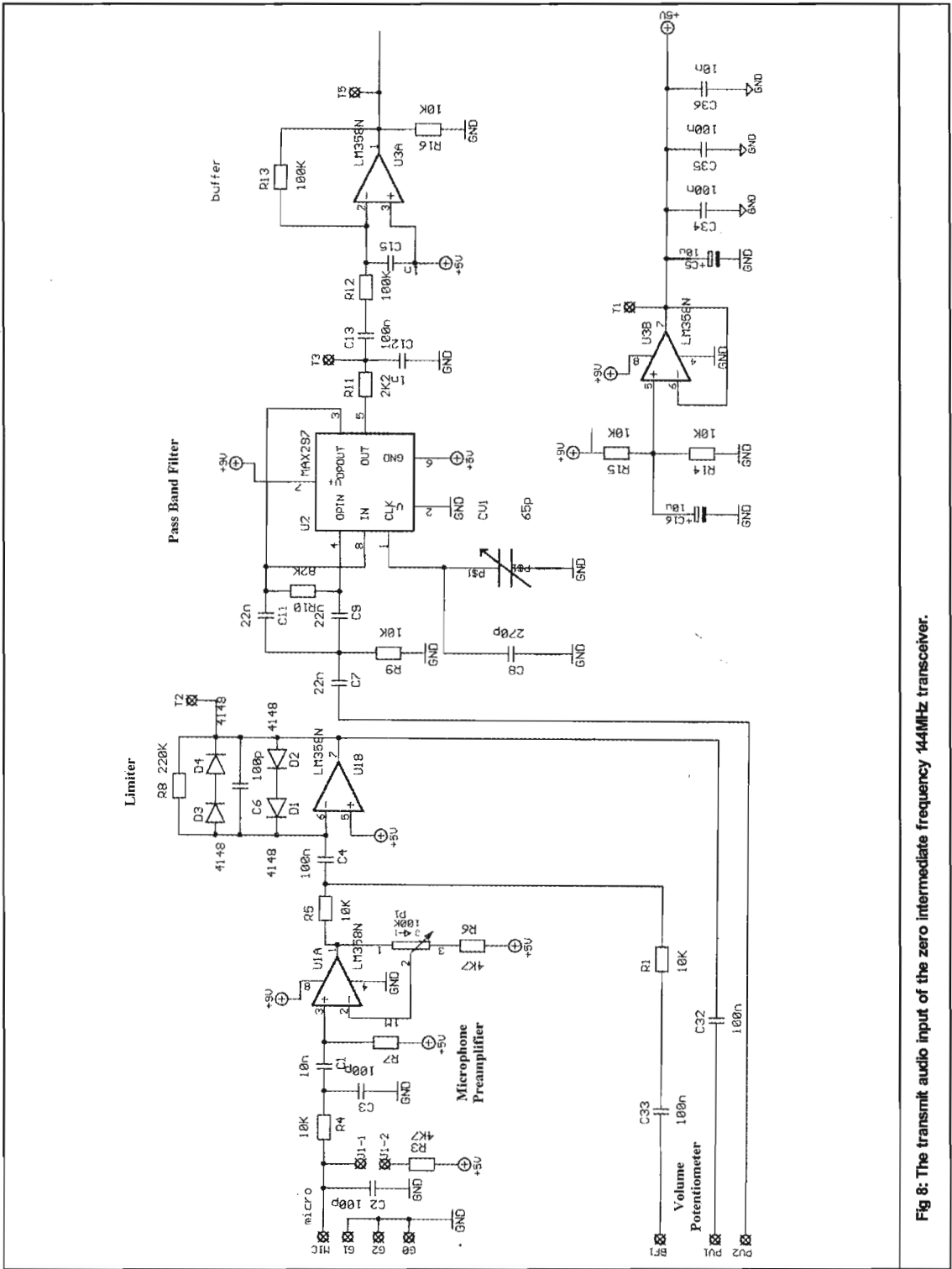

Fig 8: The transmit audio input of the zero intermediate frequency 144MHz transmitter.

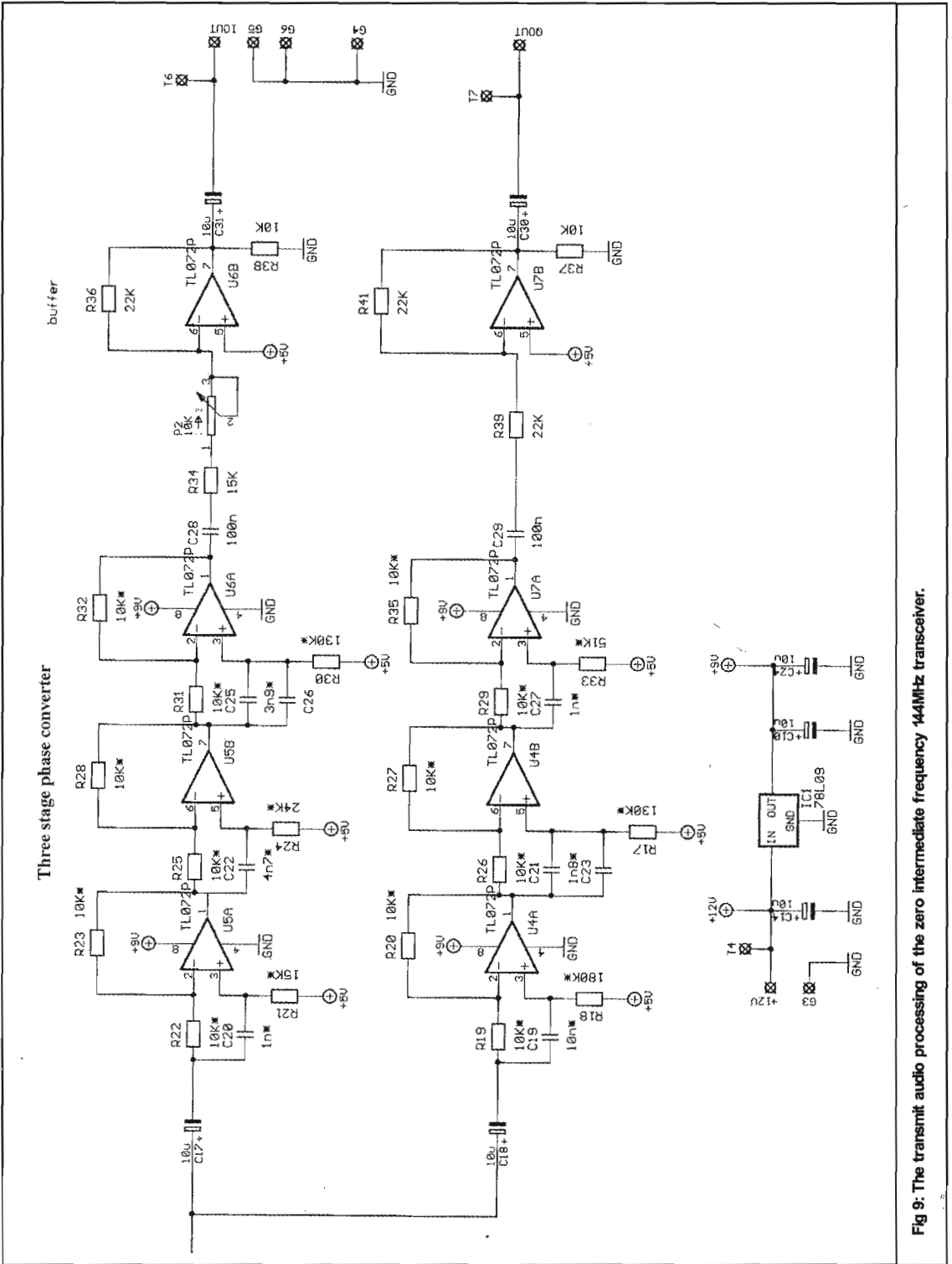

Fig 9: The transmit audio processing of the zero intermediate frequency 144MHz transceiver.

Microwave Projects

Local oscillator

This consists of a 24MHz VXO, the frequency is adjusted by means of a varicap diode, and a ten turn potentiometer (Fig. 10). An RIT can be used for reception using a potentiometer with a notch at the central position, thus a click can be felt when the knob is rotated. A switch makes it possible to select one of four oscillators to cover four ranges of at least 200kHz within the 144-146MHz band. In contrast to the VXO of the IC-202, the switching is not effected via VHF, but through the DC feed of the selected oscillator. This avoids interference from other capacities, which would reduce the range covered by the varicap diode (remember that in the IC-202 the frequency variation is given by a double variable capacitor linked to adjusting capacitors). The crystals used on the equipment and the ranges covered are as follows:

- 24.038MHz crystal:- 144 to 144,200MHz
- 24.071MHz crystal:- 144.271 to 144.400MHz
- 24.133 MHz crystal:- 144.600 to 144.800MHz
- 24.172 MHz crystal:- 144.800 to 145.000MHz

The oscillator is followed by the multiplier stages and an amplifier stage, to provide the level required in the 144MHz band (Fig. 11). In the same module there is a divider (x 10) supplying the signal for the frequency meter.

Auxiliary circuits

The following auxiliary functions are on a single printed circuit (Figs. 12 and 13):

A DC voltage regulator, with reverse polarity protection, limits the voltage applied to various modules to 12 Volts. The other modules include second regulation if necessary, as for the VXO, for example.

A PIC based circuit controls the selection of the type of transmission and its generation, CW, SSB, pips, message, tune. It also controls the switching from transmit to receive, with a "K" at the end of the message. Signals in CW, tune and pips are at approximately 800Hz.

An S-meter, using a logarithmic amplifier, receives one of the audio signals, taken from the output of the first IF amplifier stage, before the automatic gain control. This allows a linear deviation, in decibels, from the signal received (scale of 100dB).

Frequency meter

The 24MHz signal generated by the local oscillator is divided by ten using an ECL divider to feed the frequency meter module. This is made up of a gate, two counters (16 bit counting), a PIC and a two line by 16 character back lit display (Figs. 14 and 15). The PIC and its 20MHz crystal control the frequency meter, generating the gate opening time (0.1 seconds) and all the

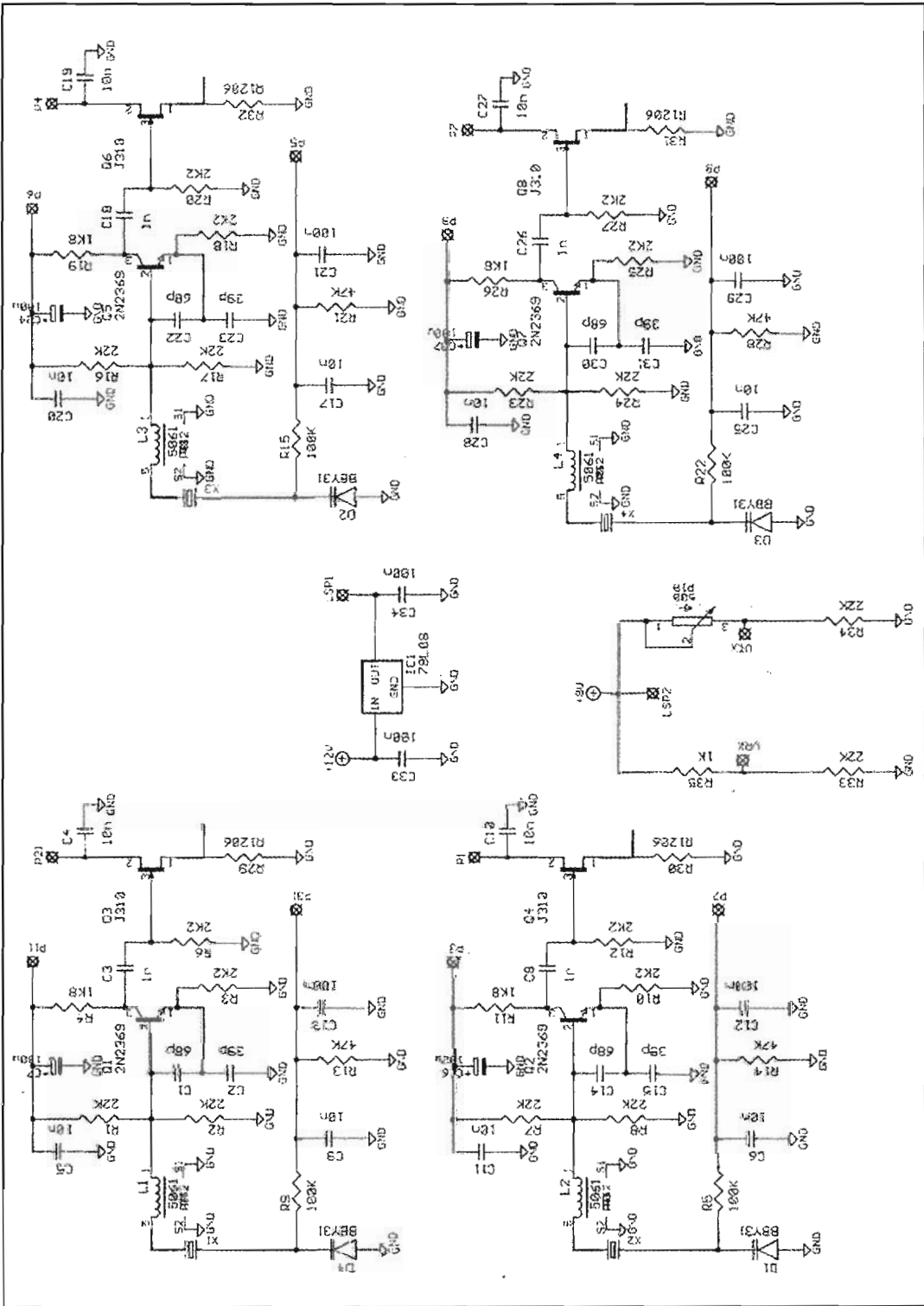

Fig 10: The local oscillator of the zero intermediate frequency 144MHz transceiver.

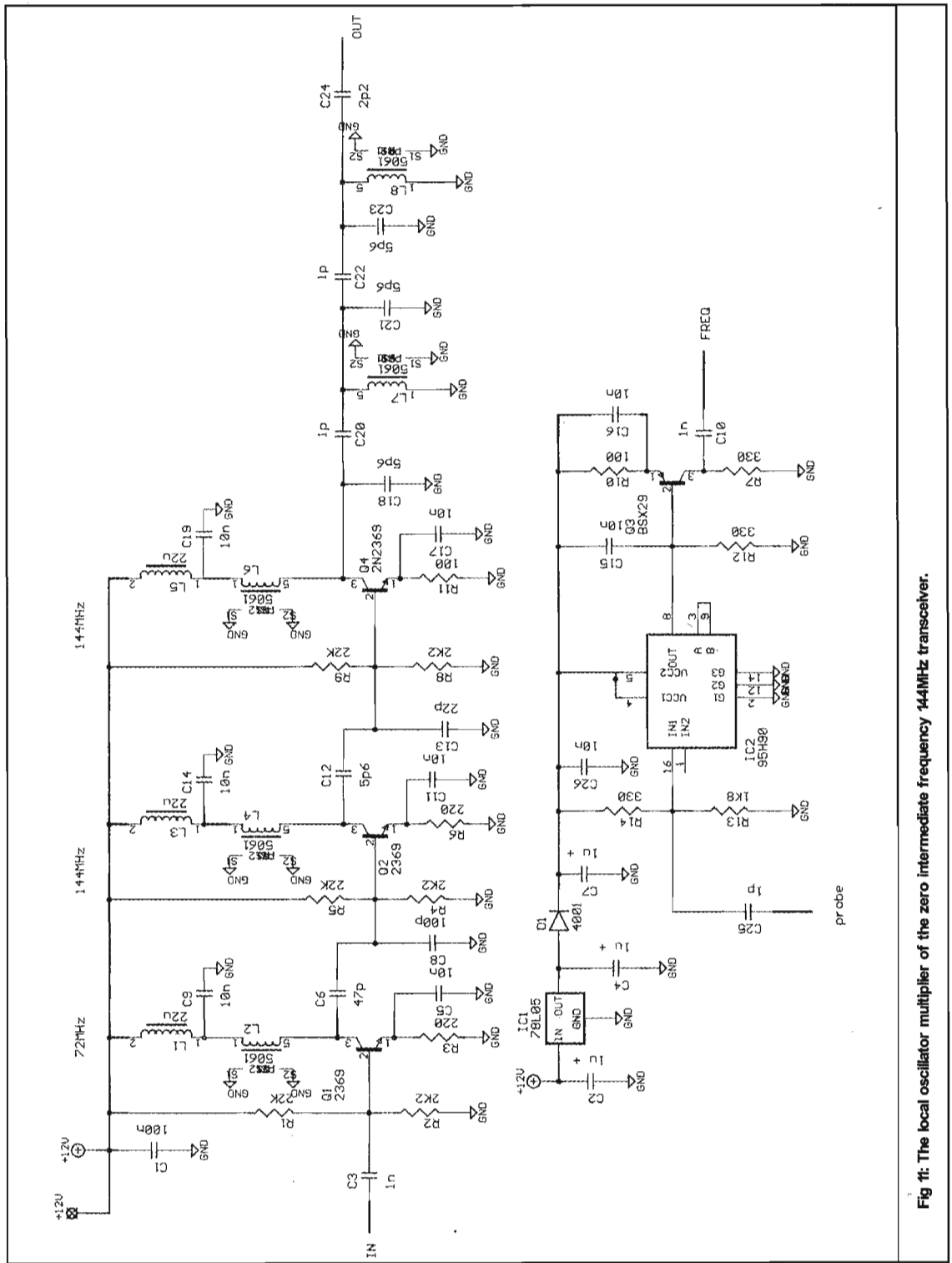

Fig 11: The local oscillator multiplier of the zero intermediate frequency 144MHz transceiver.

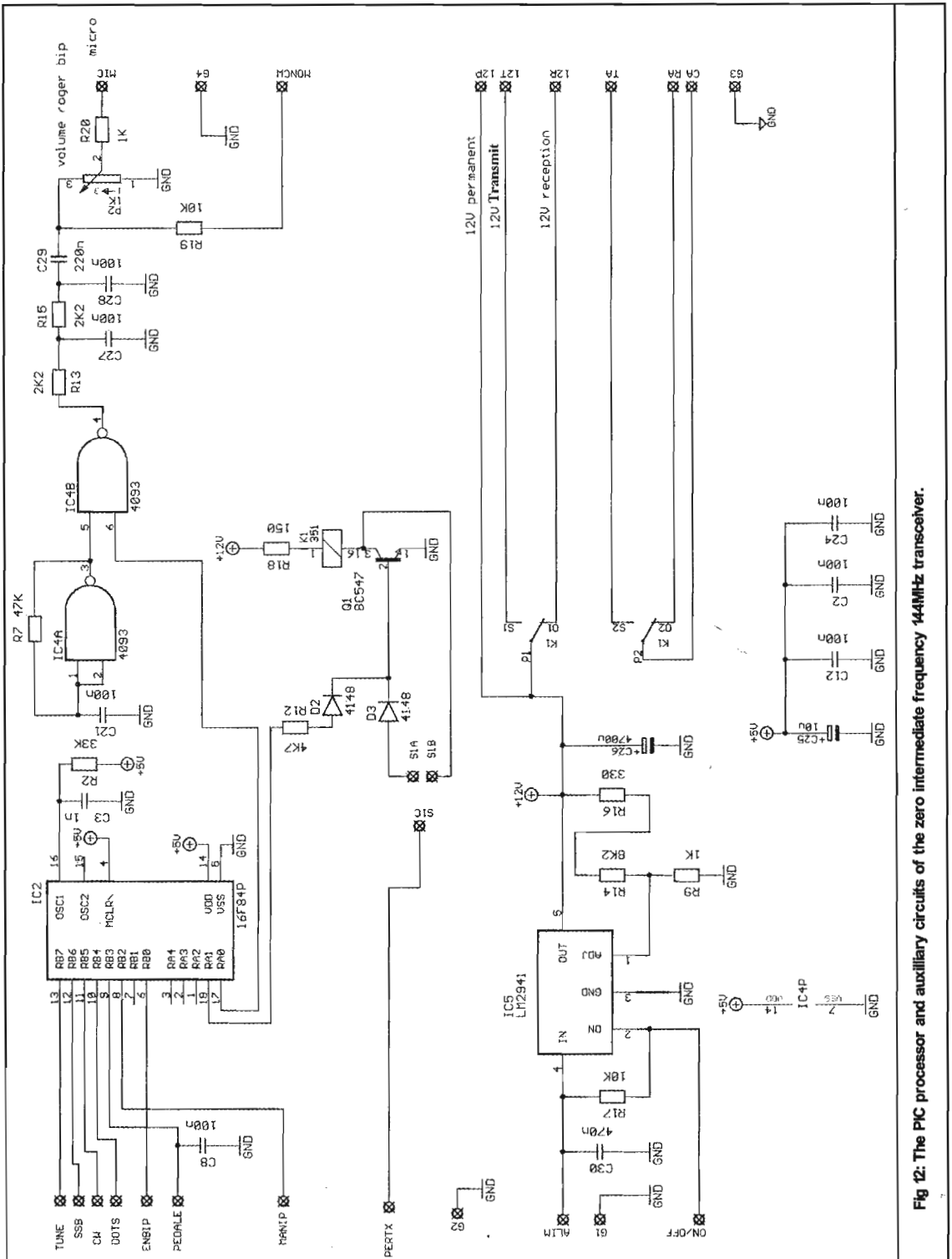

Fig 12: The PIC processor and auxiliary circuits of the zero intermediate frequency 144MHz transceiver.

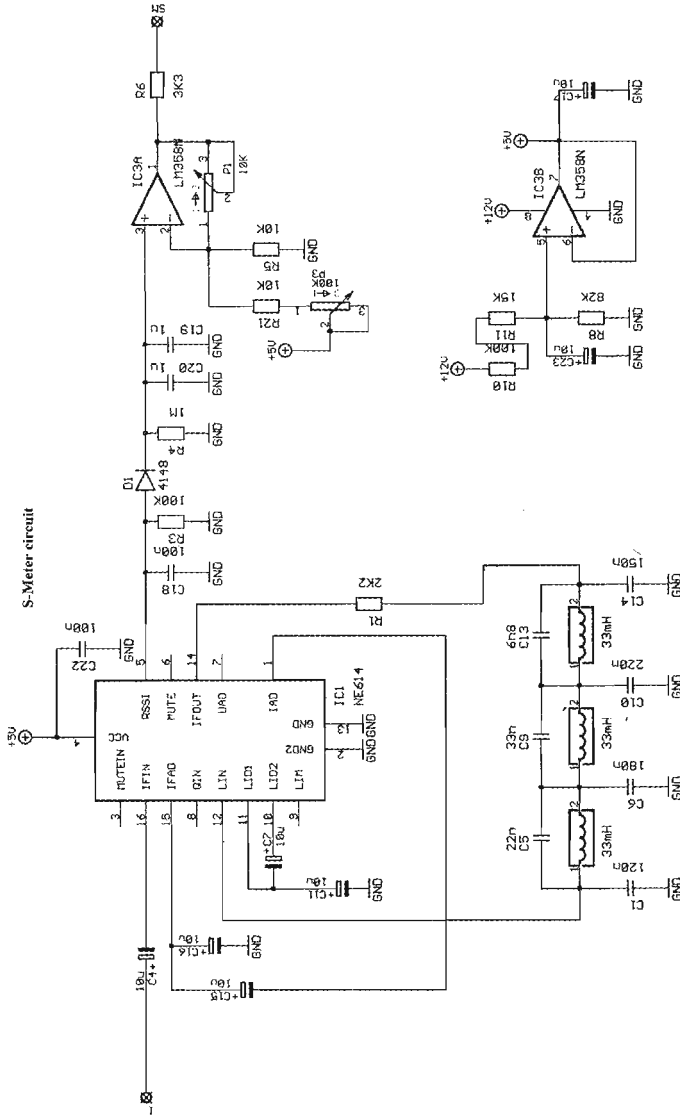

Fig 13: The S-meter of the zero intermediate frequency 144MHz transceiver.

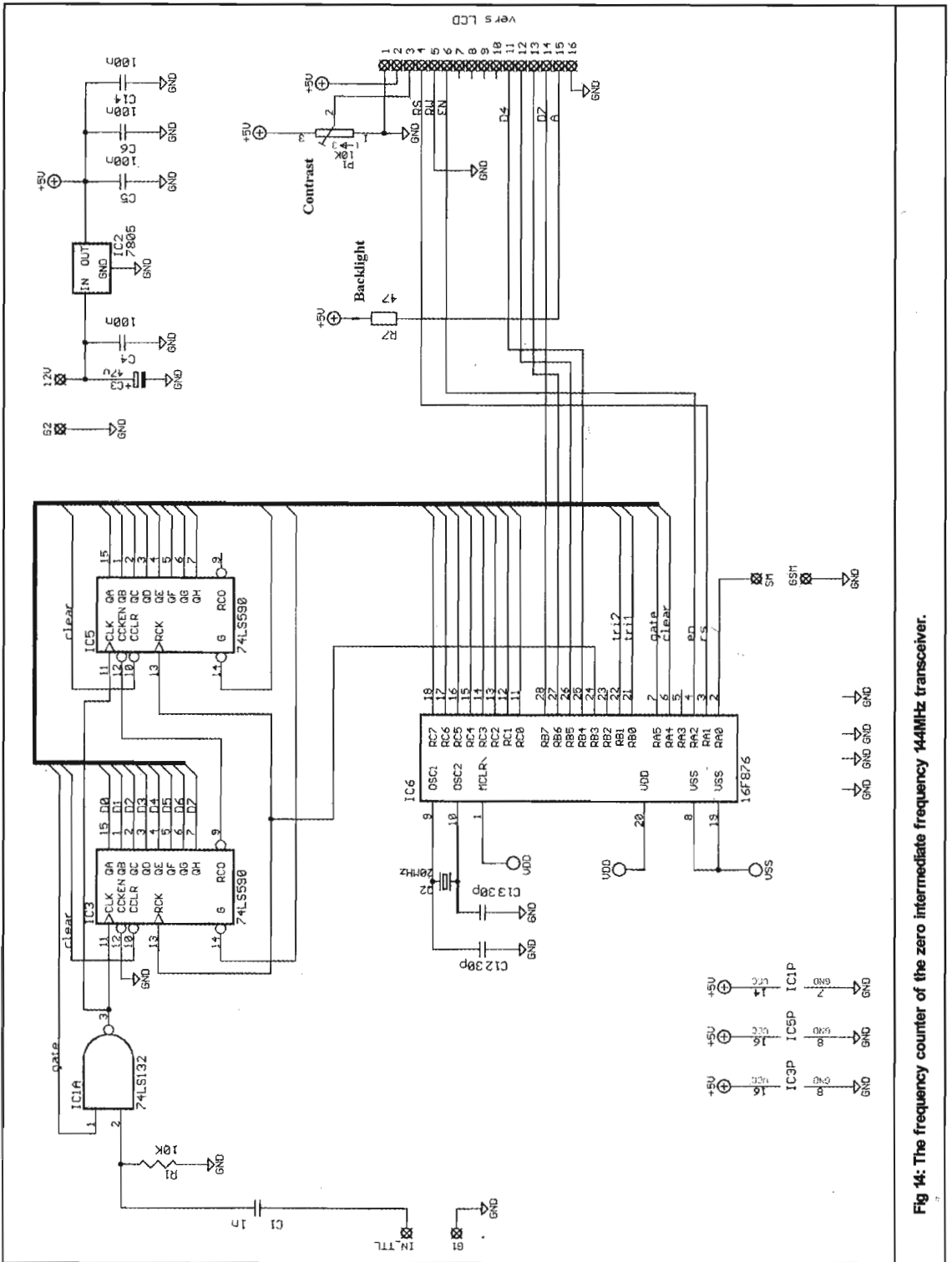

Fig 14: The frequency counter of the zero intermediate frequency 144MHz transceiver.

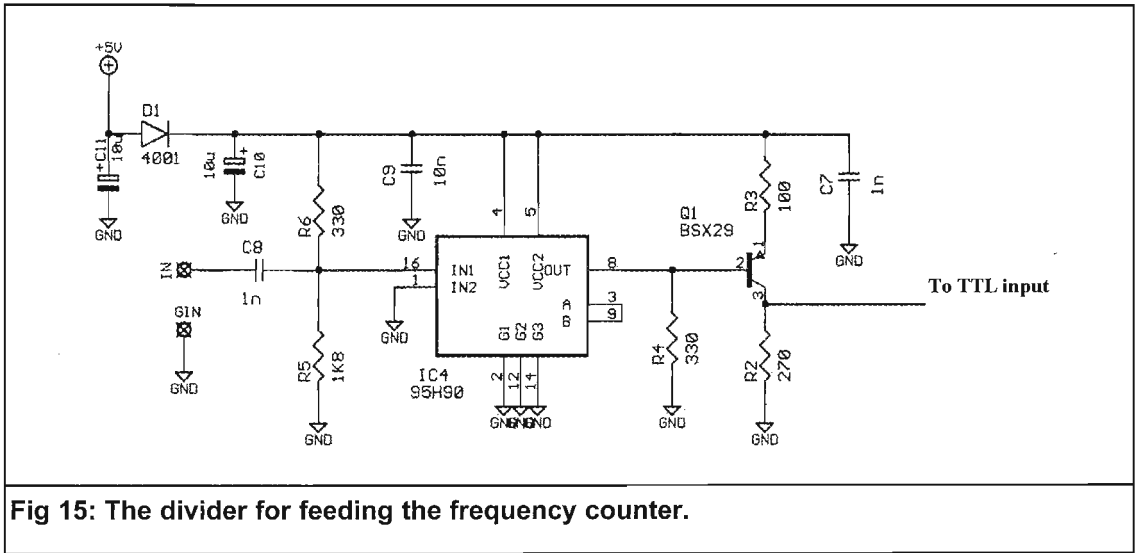

Fig 15: The divider for feeding the frequency counter.

signals required for LCD display. The PIC code is optimised in order to measure frequencies in the 2m band, with a refresh time in the order of 120ms. The PIC clock frequency can be adjusted using a capacitor for an accurate display.

The analogue/digital converter function of the PIC is used to produce an S-meter display as a bar graph with a length proportional to the logarithm of the signal received.

Parrot

A recorder repeater makes it possible to modulate the transmitter, using a single or repeated message (Fig. 16). The recording uses an electret microphone, mounted at the back of the transceiver, with knobs for the various operations necessary.

Switching operations

Two switches make it possible to select the range of frequencies received and the functioning mode. Figs. 17, 18 and 19 show how they are connected up to the various modules.

Assembly

The transceiver is housed in a metal box that has the only controls strictly necessary for SHF operating on its front panel:

- Selection of range covered at 144MHz .

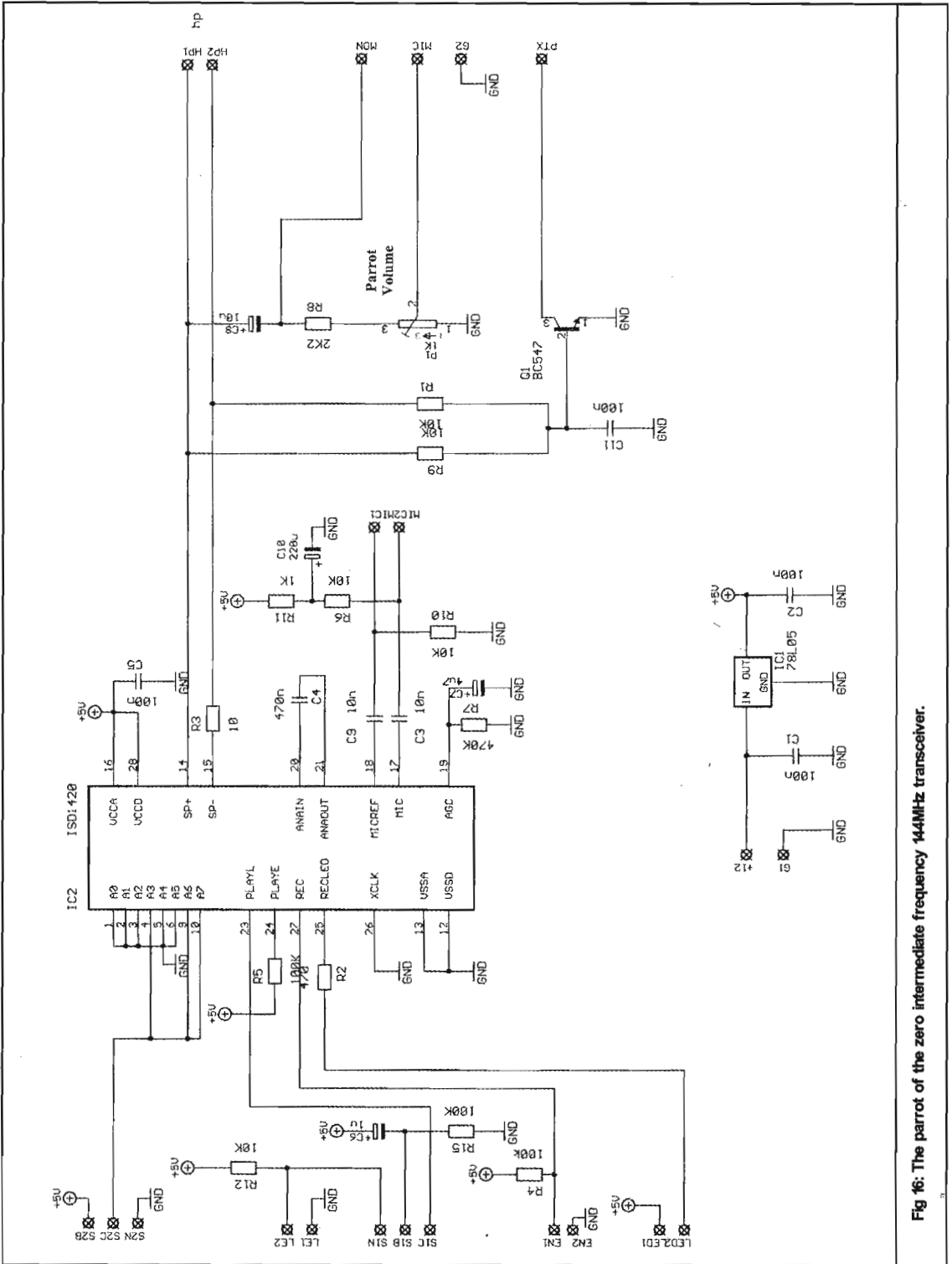

Fig 16: The parrot of the zero intermediate frequency 144MHz transceiver.

Microwave Projects

AGC. The second receiver module can be tested using an audio generator, preferably followed by a buffer stage supplying two square wave signals. The transmit modulator should be excited by an audio generator, and we can check that the outputs are square wave. The compressor is to be adjusted as desired.

The VHF module should be tested in receive mode, with the local oscillator connected. Applying a 145MHz signal to the TNC socket will make it possible to adjust the input stage by measuring the output voltages I and Q, the input VHF signal being offset by approximately 1.5kHz in relation to the local oscillator frequency. It is possible to adjust the three adjustments, antenna and coupling, to obtain a flat pass band of between 144 and 146MHz, or to favour the most frequently used range, for example, from 144 to 144.200MHz for use with a 10GHz transverter. The phase difference of outputs I and Q can be checked by creating a Lissajous figure with a two channel oscilloscope, which should show a circle. During transmit, with the local oscillator connected, two square wave I and Q produced as referred to for the receive section will make it possible to generate a 145MHz signal. This can be tuned for a maximum value using the adjustable capacitors.

When all the modules are functioning correctly, it is time to install them into the housing, to check that the assembly is operating properly, and to fine tune the settings.

Conclusion

I have no regrets about this long project, which has taken me two years. In the course of the project, I have had to consult numerous texts and carry out numerous tests and measurements. If the result may appear not to measure up to these efforts, this is perhaps due to an excess of honesty regarding the details of the measurements carried out. After several months of use on microwave activity days, I was actually able to obtain some very satisfactory results at 10GHz, as my correspondents could confirm following our numerous contacts at distances of close to 500 kilometres, in spite of a very modest parabola with a diameter of 48 centimetres.

F5CAUs contribution

Now we must render unto Caesar the things that are Caesar's. Our friend Gil, F5CAU, has indeed been kind enough to agree to a request I made in *Hyper*. I was looking for an OM capable of designing printed circuits to professional standards, which is totally beyond me. He not only carried out this work but he also designed the frequency meter, the 800Hz generator and the PIC for the auxiliary modules. He also gave me some helpful advice during this project, and I would like to thank him once again.

In addition, as the assembly instructions are too extensive to be published in full in here, he has undertaken to post it on his Internet site, where you can download the printed circuit drawings and some other useful documents free of charge: <http://perso.wanadoo.fr/f5cau>. Note: the documents on this web site are in French but the PIC code can also be found on the VHF Communications web site: <http://www.vhfcomm.co.uk>

Microtransmitter for L-band (microtx), Paolo Pitacco IW3QBN [15]

This is my solution to generate a stable signal on L-band. It is useful to transmit ATV, high speed digital signals or simply as local oscillator for a transverter.

Introduction

Most amateurs refuse to go on SHF bands because of the difficult to easily generate a stable and reliable signal. Normally this is achieved using an expensive chain of multipliers from a crystal oscillator. Tuning is the big obstacle, especially when only a simple test meter is available in the ham-shack. The project presented here will demonstrate that it is possible to do all that is required in a simple and easy manner.

Due to the growth of wireless technology and related applications, it is easy today to access complex circuitry without any dedicated instruments. I refer to developments in the field of micro-controllers and rf modules, today we can have complex functions ready to use in a single package:

- Microprocessors are made smaller having more peripherals and are re-programmable "in circuit".
- Wide band amplifiers, MMIC are matched to 50 ohms.
- Voltage controlled oscillators (VCO) and the components for the control of these (PLL).

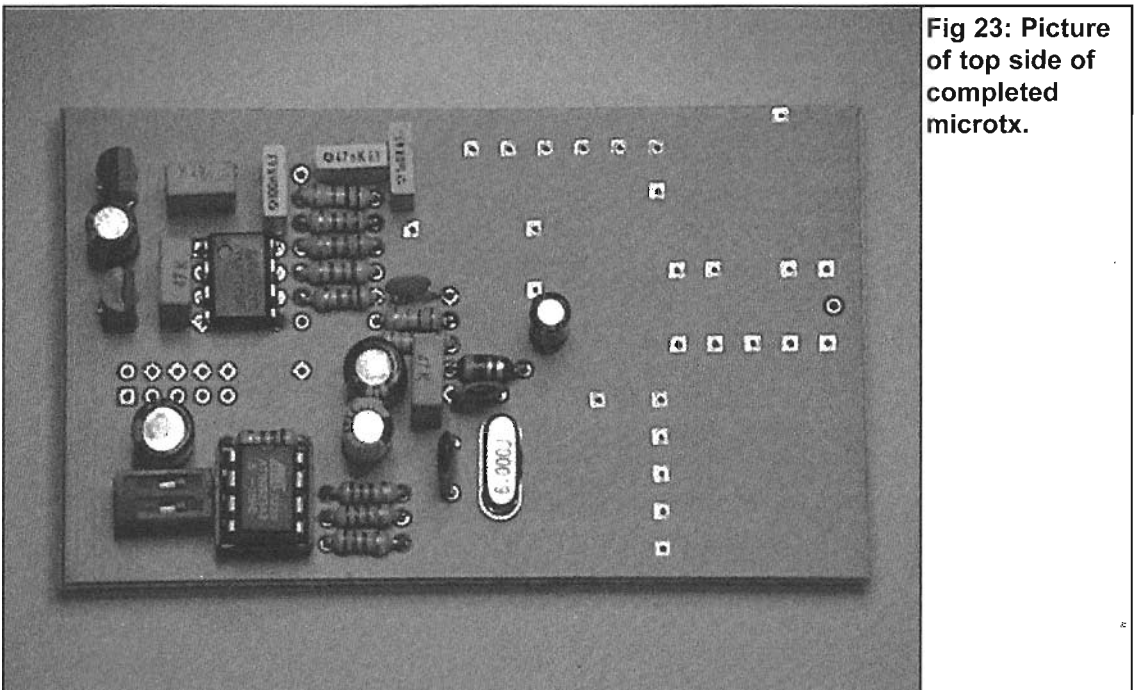

Fig 23: Picture of top side of completed microtx.

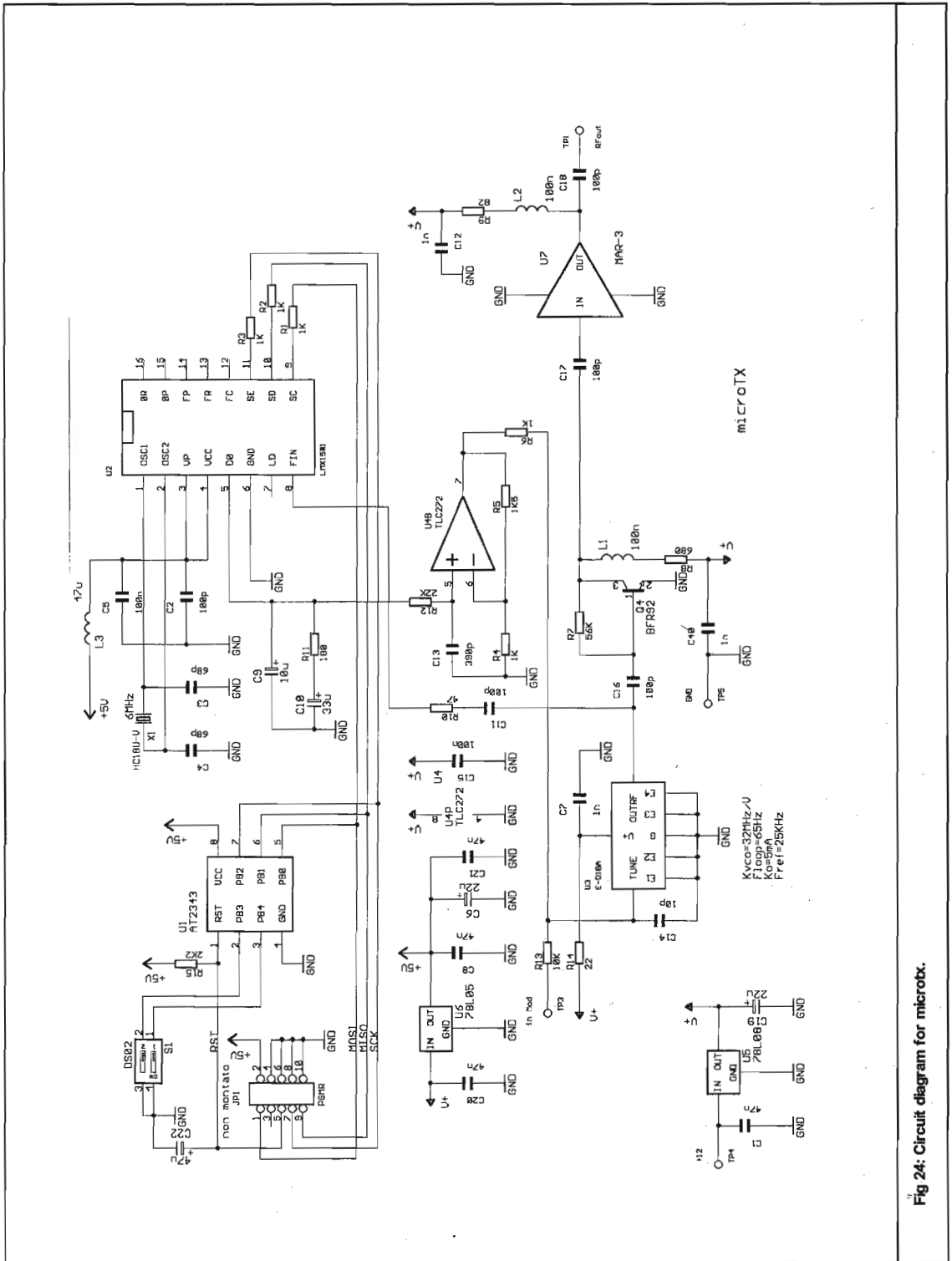
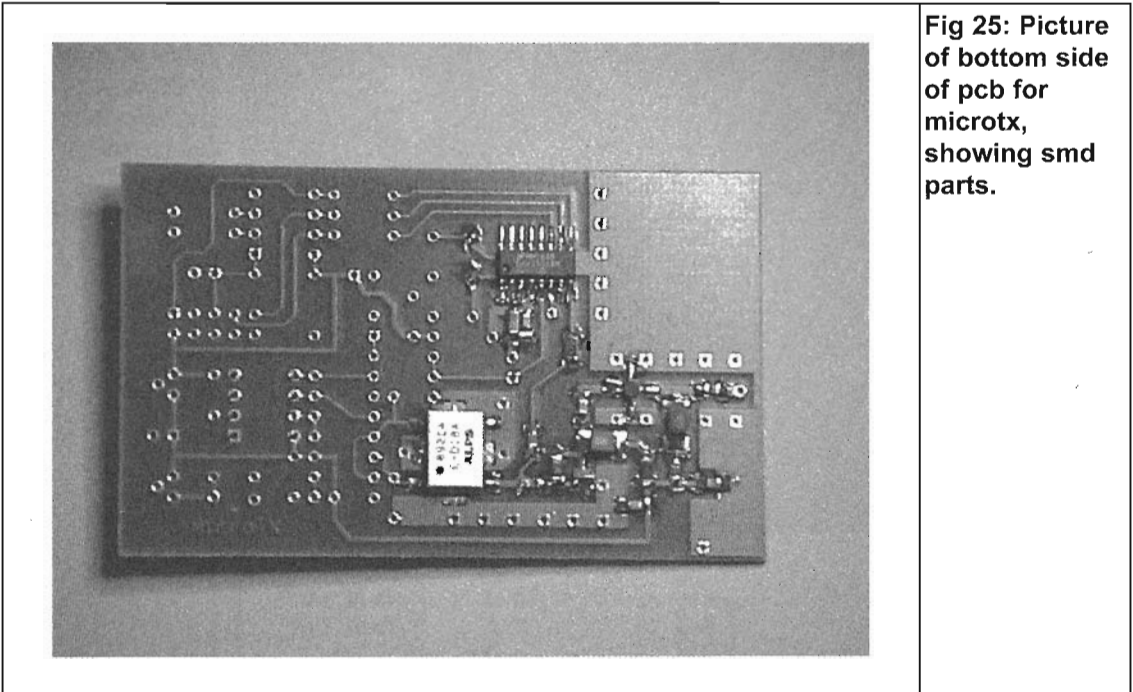

Fig 24: Circuit diagram for microbx.



Using these technological solutions, it is very easy to design a stable and re-programmable oscillator with few parts. The result is shown in the Fig 23, a small pcb gives a great circuit.

Circuit description

The circuit diagram is very simple (see Fig 24), a major factor is the absence of any variable (externally tuneable) elements. The RF part is built around a commercial (ready-to-go) smd VCO functioning between 1100 and 1400MHz, ALPS model ED18-A. A buffer transistor and an MMIC amplifier are used for an output stage.

VCO control is achieved using a National PLL, LMX1501, programmed by a small and inexpensive micro-controller from Atmel, AT90S2343. This is the little member (dimensionally speaking) of the AVR family from Atmel, and has only 8 pins! With an internal oscillator (RC), this device does not require an external oscillator or crystal. Two pins are used for frequency selection. I wrote the program for this small micro-controller to select one of 4 frequencies used for ATV traffic in my country (Italy). These are 1224, 1240, 1256 and 1272MHz. Any change in the switch position during operation changes the output frequency, because the switch setting is checked continuously by the micro-controller. The loop filter is calculated for a VCO sensitivity $K_{vco}=32\text{MHz/V}$ and a reference frequency $F_{ref}=25\text{KHz}$, using National's information from the LMX1501 datasheet [14], all values were used to obtain a good carrier for ATV transmission. The LMX1501 is a good device that works well from VHF to SHF with enough sensitivity. It is fully programmable (pre-scaler, reference and divider) in serial mode using National's Microwire interface (3 wire: clock, data and latch). The PLL uses a 6MHz crystal for internal reference

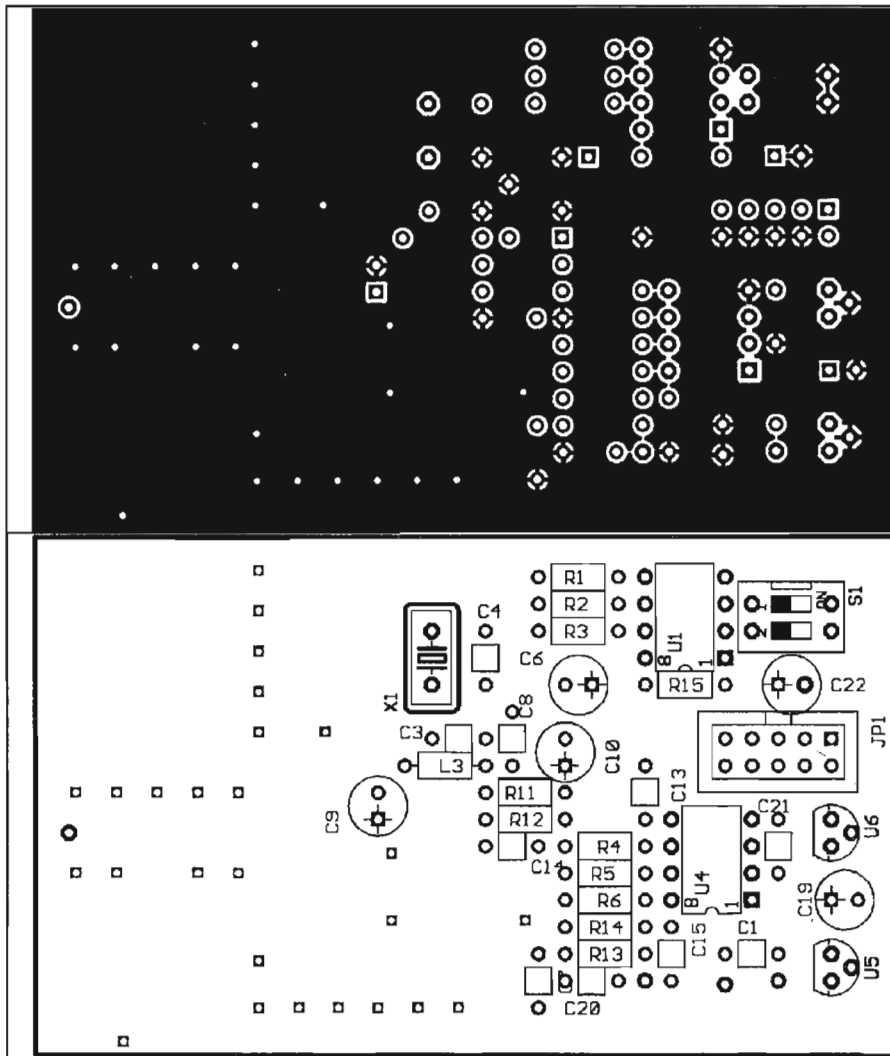

Fig 26: Top side of microtx PCB and component layout for normal insertion parts.

oscillator. Any other frequencies in the VCO's range of operation are possible by re-programming the micro-controller. For this reason I have made provision on the pcb for a connector used by the Atmel ISP dongle, this is not installed for normal and "standard ATV" versions. Software tools are available directly from Atmel [12] moreover a lot of suggestion and applications are available on the internet [13].

Construction

To make the circuit as simple as possible, I decided to use a mix of component technology, normal insertion parts for micro-controller, power regulation and loop filter, smd parts for the rf side. The pcb is designed in the same way: a component side with all insertion parts, and a

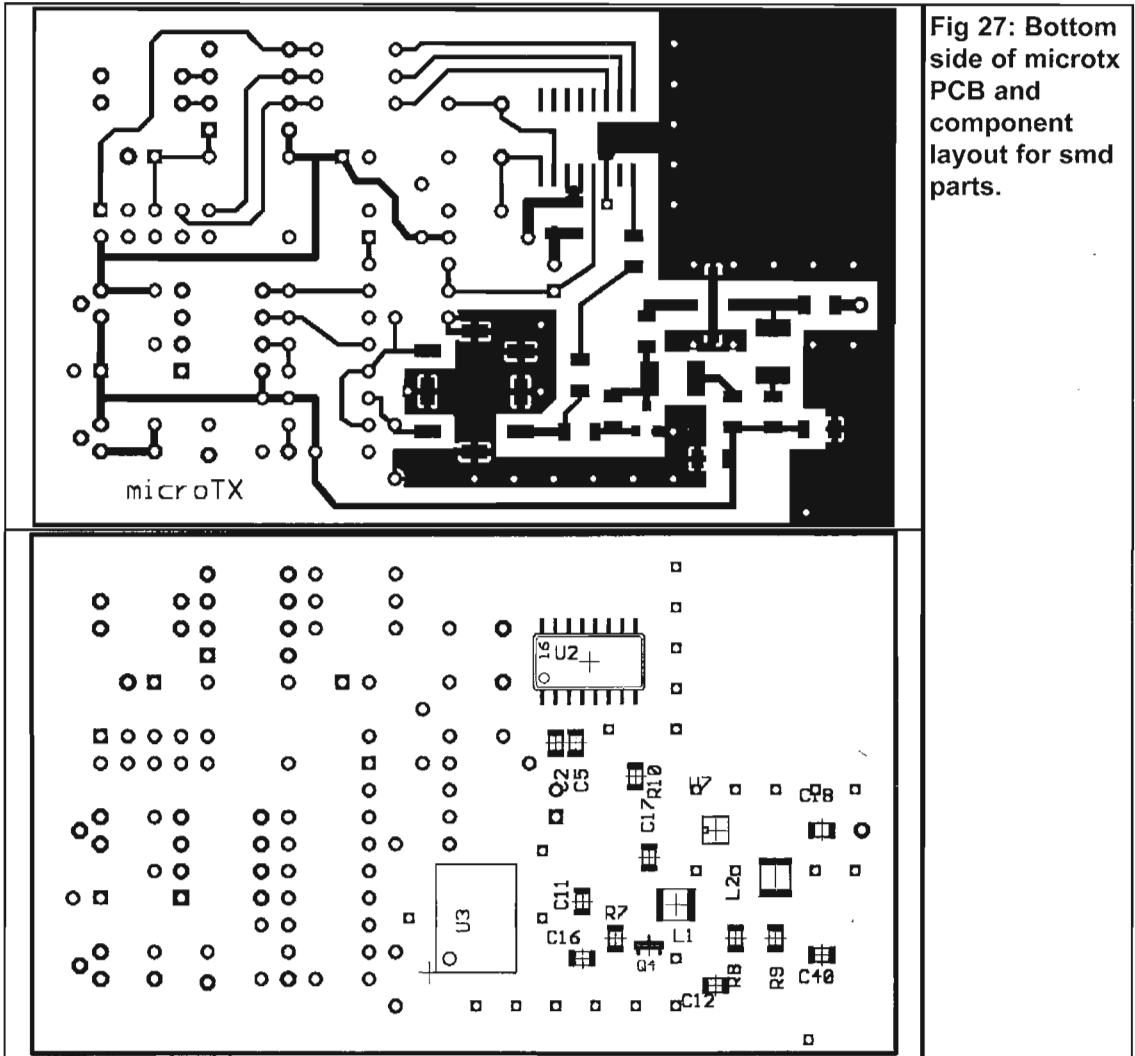

Fig 27: Bottom side of microtx PCB and component layout for smd parts.

solder side with all smd parts. This design reduces interference between rf parts and micro-controller without great screening or filtering. The bottom side is shown in Fig 25. Another design criteria was to use a minimum of smd parts which are not currently accepted by radio amateurs. After component installation, no tuning is required for stable and controlled operation, this represent a big satisfaction for all! Measured power output (on my HP432A) is greater than +10dBm in all cases, and is suitable to fully drive a power amplifier (e.g. Mitsubishi model M67715) to reach 2W output. The pcb, shown in Fig 26 (top) and Fig 27 (bottom), and all parts, are available by sending an email for the attention of IV3KAE to elenuova@tin.it

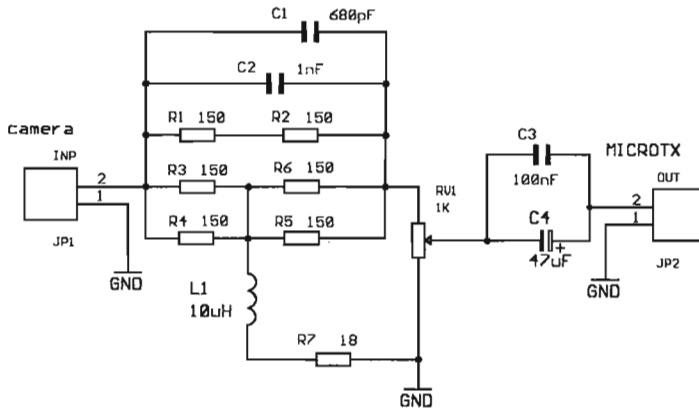

Fig 28: Filter for use with microtx as an ATV transmitter.

Applications

The primary use is an ATV transmitter and it is good practice to use a filter between base-band signal and modulation input (R13) as shown in Fig 28, but some others are possible (and tested). In order to have audio capability, you can use the circuit shown in Fig 29 as a 6.5MHz sub-carrier, and using the second half of U4 as audio amplifier. Set the inductor coil for centre frequency, RV2 for enough deviation and RV1 to set the sub-carrier level 14dB down from video carrier (with spectrum analyser). A prototype has flown on some model aeroplanes (RC) with good performance.

I have done a test as high speed digital transmitter simply by substitution of video base-band signal with a stream of 38400 Baud Manchester encoded data.

Another test was carried out for generation of 2400MHz using a doubler. I have programmed an output frequency of 1200MHz and connected the tx output to a simple doubler using a diode (HP2800) followed by a Murata filter for ISM band (2400-2480MHz), the filtered second harmonic was amplified by an MMIC (ERA3). In this manner a simple beacon for S-band was realised, again without tuning elements (Murata filter are small boxes without screws!).

For the satellite enthusiast, it is possible to use this circuit as local oscillator for a transverter for 144 - 1268MHz "mode L" up-link of satellites (i.e. AO-40). With a programmed 1124MHz output frequency, I feed a double balanced mixer (ADE-12 from Mini Circuits) in the LO port, and my 144MHz transmitter (with a VERY low level, controlled!) in the RF port and obtained a 1268MHz signal. Another Murata filter followed the mixer and a couple of MMICs amplified this signal to a +10dBm to drive the M67715 (2W, linear), usable for up-link to the satellite (together with a good antenna system).

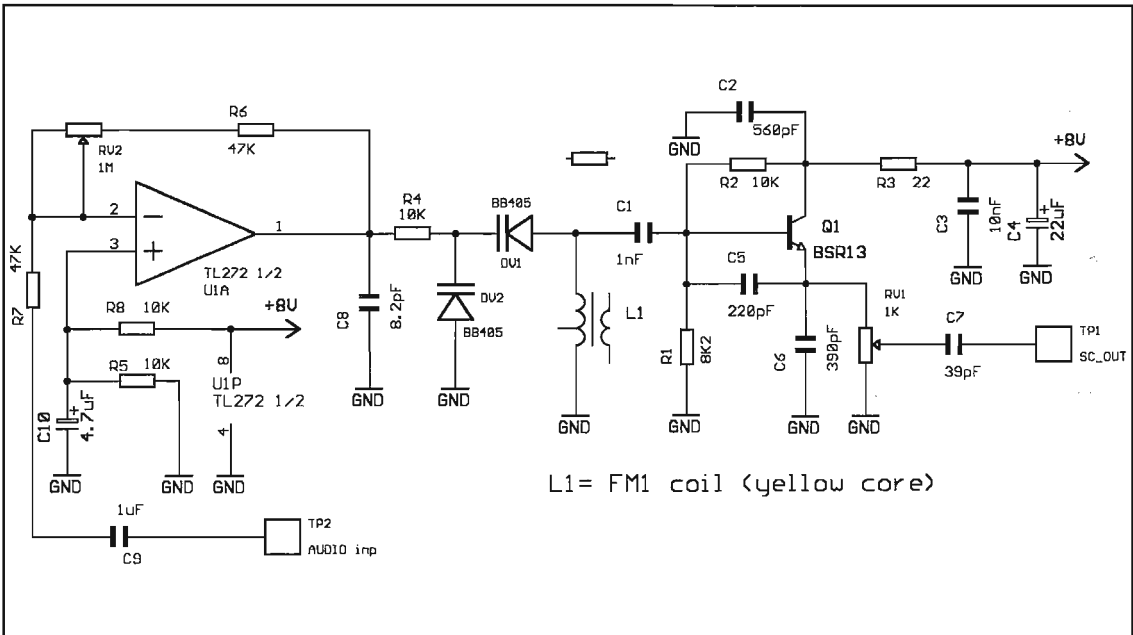

L1= FM1 coil (yellow core)

Fig 29: Circuit for using 6.5MHz sub-carrier sound with the microtx.

Conclusion

From my viewpoint, this is a simple solution, but demonstrates how it is possible to reach good results with low complexity for the experimenter. I hope that my idea will be useful to other radio amateurs.

References

- [1] RF Design Guide, Peter Vizmuller, Artech House
- [2] Radio Amateurs Equipment, F6AWN, *Mégahertz* 2/1997
- [3] What if we replaced our IC-202s? F9HX, *Hyper*, no. 37, pp. 46, 48, 54
- [4] Simple Direct-conversion VHF transmitter-receiver F1BBU, *Mégahertz* 7/2000, 2/2001, *Radio-REF* 4/2001, 6/2001 (sold as kit: see REF-Union shop)
- [5] Whats phasing-system SSB? Uncle Oscars notebooks, *Mégahertz* 7/2000
- [6] Direct Conversion Prepares for Cellular Prime Time, Patrick Mannion, *Electronic Design*, 11/1999
- [7] On the Direct Conversion Receiver A Tutorial, A.Mashour, W.Domenico, N.Beamish *Microwave Journal*, June 2001

Microwave Projects

- [8] The Generation and Demodulation of SSB Signals using the Phasing Method DB2NP, *VHF Communications* 2 and 3/1987
- [9] Weaver Method of SSB-Generation DJ9BV, *Dubus*, 3/1997
- [10] No-Tune SSB Transceivers for 1.3, 2.3, 5.7 and 10 GHz S53MV, *Dubus*, 3, 4/1997 and 1, 2/1998 and International Microwave Handbook ISBN 1-872309-83-6
- [11] Study of a very low-priced decametric transceiver F61WF, *Proceedings of CJ*, 1995 and 1996
- [12] www.atmel.com
- [13] www.avrfreaks.net
- [14] www.national.com
- [15] Paolo Pitacco IW3QBN, e-mail: iw3qbn@amsat.org

Transverters

In this chapter :

- Building blocks for a 23cm transverter
- 10GHz Transverter from Surplus Qualcomm OmniTracks Units
- A "building block" 5750MHz transverter design

There are many kits and ready-made transverters available to the radio amateur who wants to operate on the microwave bands. This chapter contains some alternative approaches ranging from design concepts through to modification of surplus equipment.

Building blocks for a 23cm transverter, Daniel Upström, SM6VFZ

Introduction

For the technically interested radio amateur, the 23cm band should be of great interest. The frequency is high enough for the introduction of components based on transmission lines in the layout of a printed circuit board, but not too high for the use of easily available components and laminate board. When it comes to operating modes, the 23cm band offers the possibility of wideband modes like ATV and high-speed digital modes together with an almost infinite number of channels for NBFM. For those interested in weak-signal modes and wave propagation there is tropo, aeroplane scatter, EME with low background noise, satellites and much more.

The easiest way to get QRV on 23cm is probably to use a transverter together with a radio for a more common band like 2m. A block diagram of a transverter is shown in Fig 1, the remainder of this article will cover a discussion about these building blocks.

Mixer

The main function of a transverter is to mix between two frequencies. The signal from a frequency stable local oscillator (LO) is mixed with either a received signal or a locally generated signal. This results in conversion between two frequency bands, in both directions. This tells us that the first discrete building block we need is a mixer. Its job is to function as a mathematical multiplier for the signals fed into it. We can see from equation (1) that if we are able to multiply two signals or waves represented as cosine functions, we get the sum and the difference frequencies:

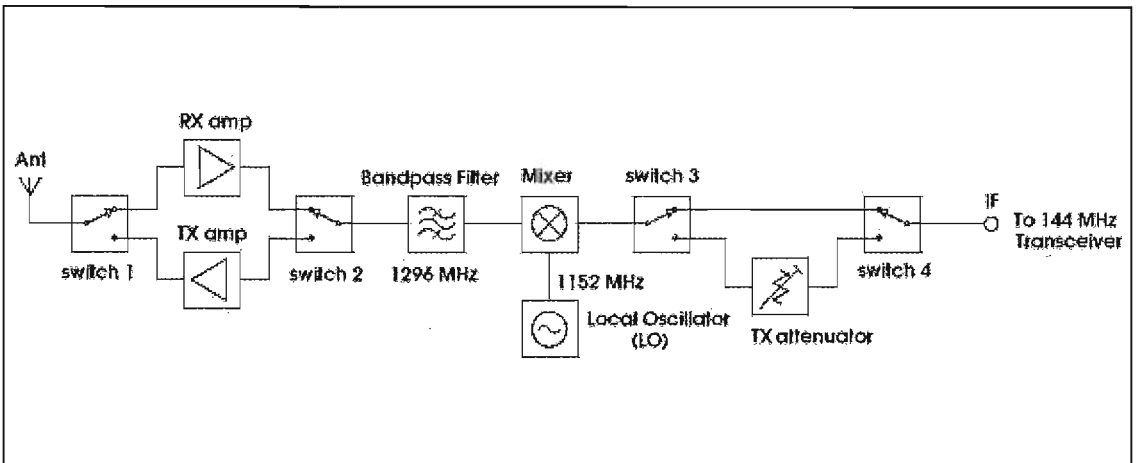

Fig 1: Block diagram of a 23cm transverter.

$$\cos(\omega_1 t) \cos(\omega_2 t) = \frac{\cos((\omega_1 + \omega_2)t) + \cos((\omega_1 - \omega_2)t)}{2} \quad (1)$$

To be able to multiply two signals like this we need a non-linear device. This could be a diode, a transistor, a valve or some other device that shows non-linear properties. The quality of a mixer depends on to what extent the signals are multiplied. If a high amplitude signal is applied to a non-linear device, higher order harmonics will always be generated and, because of this, most mixers will produce signals, not just those described in equation (1).

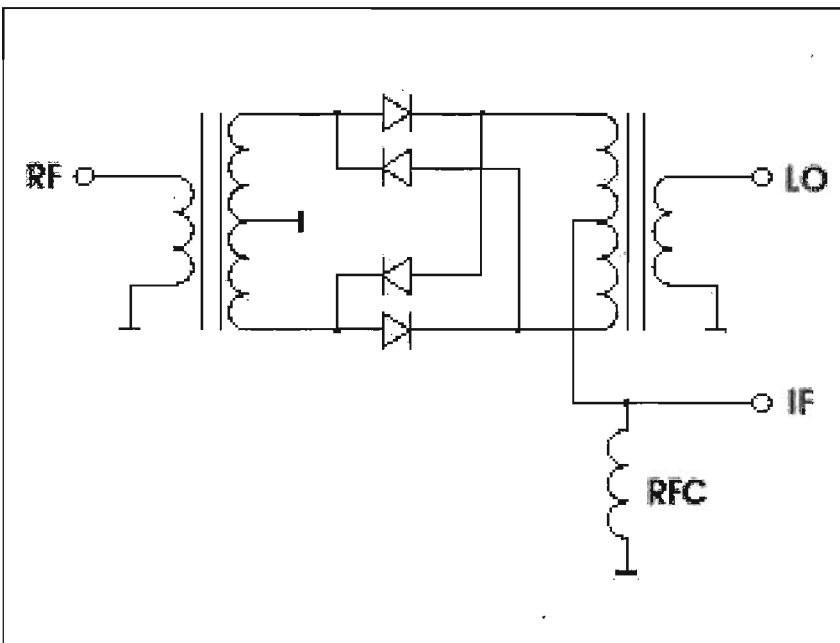

Fig 2: Diagram of a doubly balanced mixer.

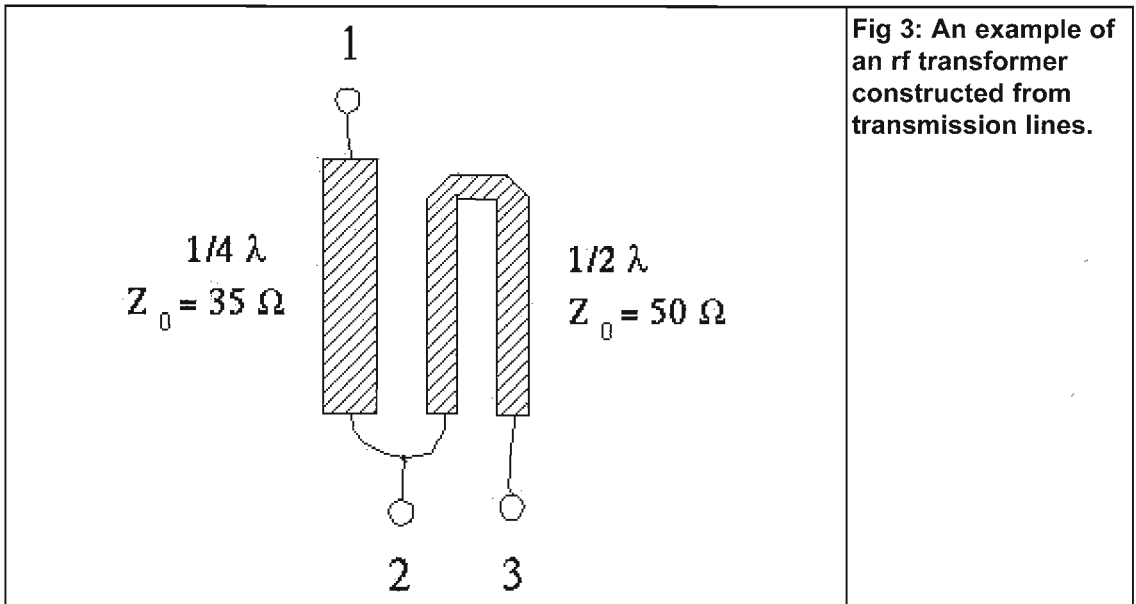

Fig 3: An example of an rf transformer constructed from transmission lines.

If we want to convert between 1296 and 144MHz we need an LO that produces a signal on 1152MHz. When transmitting we apply both 144 and 1152MHz to the mixer. Our wanted frequency 1296MHz is generated, but we also get signals at $n \times 144$ where $n = 1,2,3,\dots$ plus $1152 - 144$, $1152 + 2 \times 144$, 2×1152 and so on, at different levels. All these signals must be filtered out if we want to amplify the signal and feed it to an antenna.

There are two main types of mixers, unbalanced and balanced. The first type generates a lot of power at unwanted harmonics, while the latter type suppresses harmonics of the applied signals, giving mainly the sum and difference frequencies from (1) at the output. This means that we have to do less filtering if we use a balanced mixer compared to an unbalanced mixer. The most common and well-known form of a doubly balanced mixer is shown in Fig 2.

The purpose of the transformers are to provide two signals with equal amplitude with respect to ground but with 180 degrees phase difference. At high frequencies it is often not that easy to make good RF transformers by simply winding wire around a commercially available core. At high frequencies however, the function of a transformer could also be realised by an arrangement of transmission lines. An example of this is shown in Fig 3 where the power fed into port 1 is transmitted equally to port 2 and 3 with the desired 180 degrees phase difference. But such a solution on 1.3GHz occupies much board space. It is also not a very good idea to implement it when using a high-loss board material like glass fibre epoxy FR4. The different mechanical lengths between the paths 1 to 2 and 1 to 3 introduce a difference in power level between the ports which is often unacceptable for a balanced mixer.

In commercial designs like cell phones and other UHF equipment, ready made balanced mixers (DBMs) available in small packages are most often used. Such packaged mixers are often both expensive and hard to find in small quantities. It is important that they are specified for operation at the frequency of interest. A DBM specified up to 1000MHz (with modest specification) proved useless at 1300MHz when tested by the author.

An interesting alternative to the classical DBM approach is to use a single unbiased MOSFET

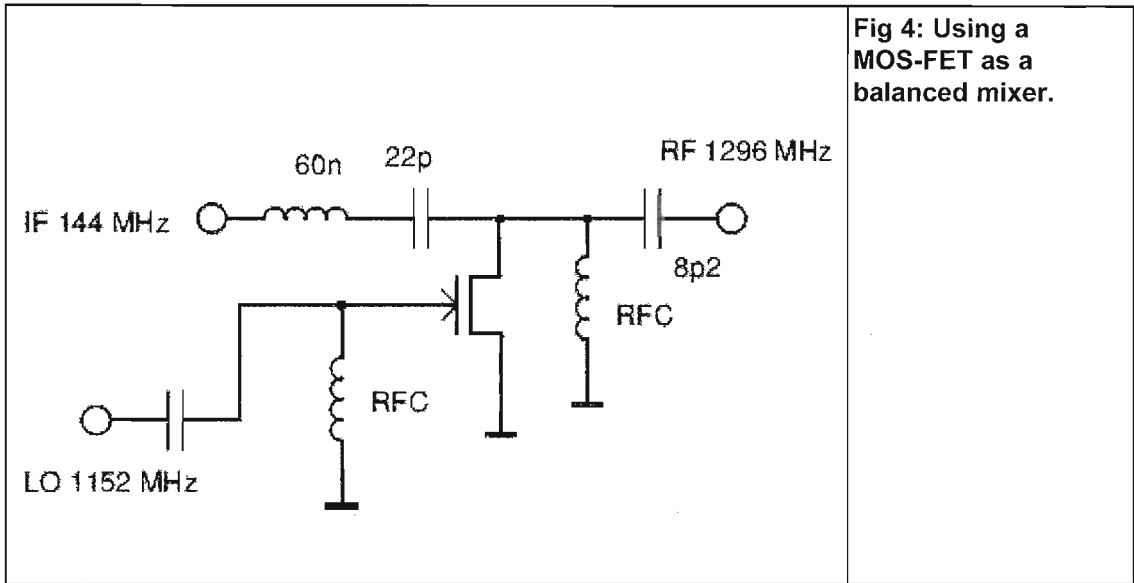

Fig 4: Using a MOS-FET as a balanced mixer.

as a balanced mixer (Fig 4), then no phasing arrangement is needed. In this circuit the MOSFET functions as a switch operated by the LO signal, just like the diodes in Fig 2. The task is to find a MOSFET with low turn on resistance and without diode protection on the gate. Further details about this type of mixer can be found in [1].

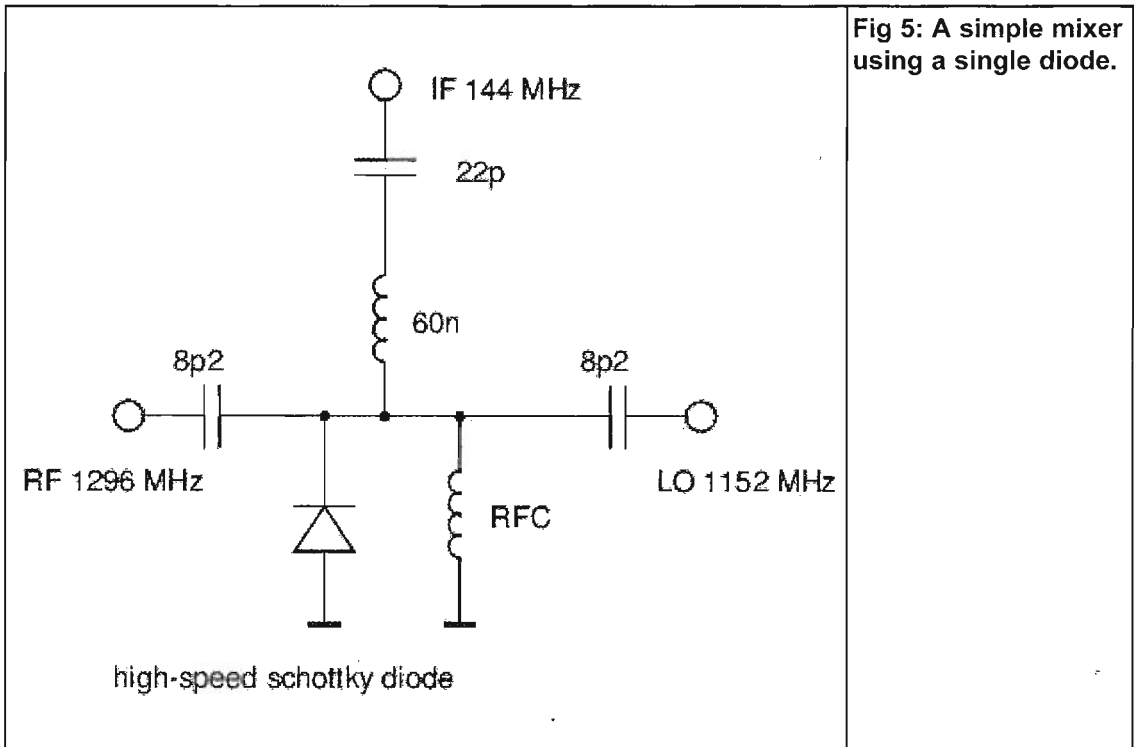

Fig 5: A simple mixer using a single diode.

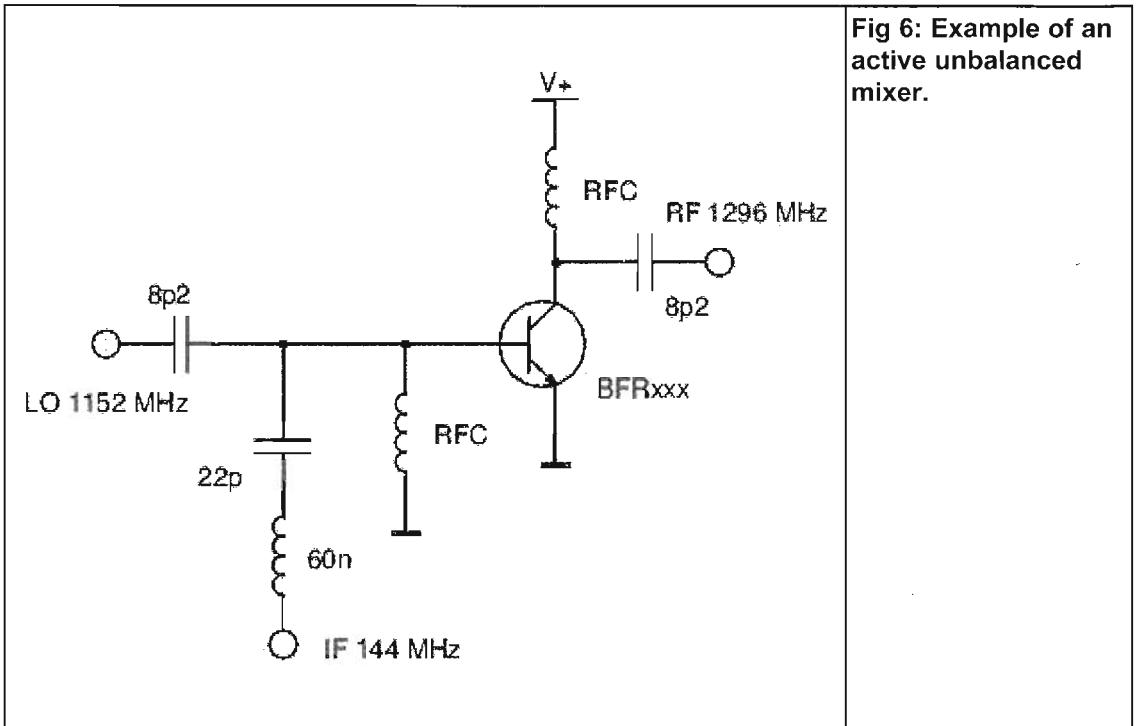

Fig 6: Example of an active unbalanced mixer.

If a lot of filtering before/after the mixer is acceptable, it is possible to use some kind of unbalanced mixer. The simplest mixer of this kind consists of a single diode (Fig 5). Just like the balanced mixers mentioned, this has the advantage that it can mix in both directions, i.e. it doesn't matter if power is applied to the IF port and taken from the RF port or vice versa.

Experiments have shown that this mixer sometimes works better with two or more diodes in parallel, probably because the impedance is closer to 50Ω .

Mixers can also be active using some kind of amplifier biased for non-linear operation. A lower conversion loss (or conversion gain) can be achieved. An unbalanced example is shown in Fig 6.

The main drawback with this type of mixer is that it can only be used in one direction, i.e. a signal on the collector can not be mixed with the LO signal (at least not with a tolerable conversion loss). This means that we need to have separate mixers for the TX and RX paths and split or switch the LO power between them.

Local Oscillator

Equally important as the mixer is of course the local oscillator. Most transverters for 23cm use a quartz crystal oscillator operating at 96MHz followed by a number of frequency multipliers, using non-linear biased amplifier stages with tuned outputs. This forms an oscillator chain. Another approach is to lock the frequency of a free running oscillator to a reference frequency in a Phase

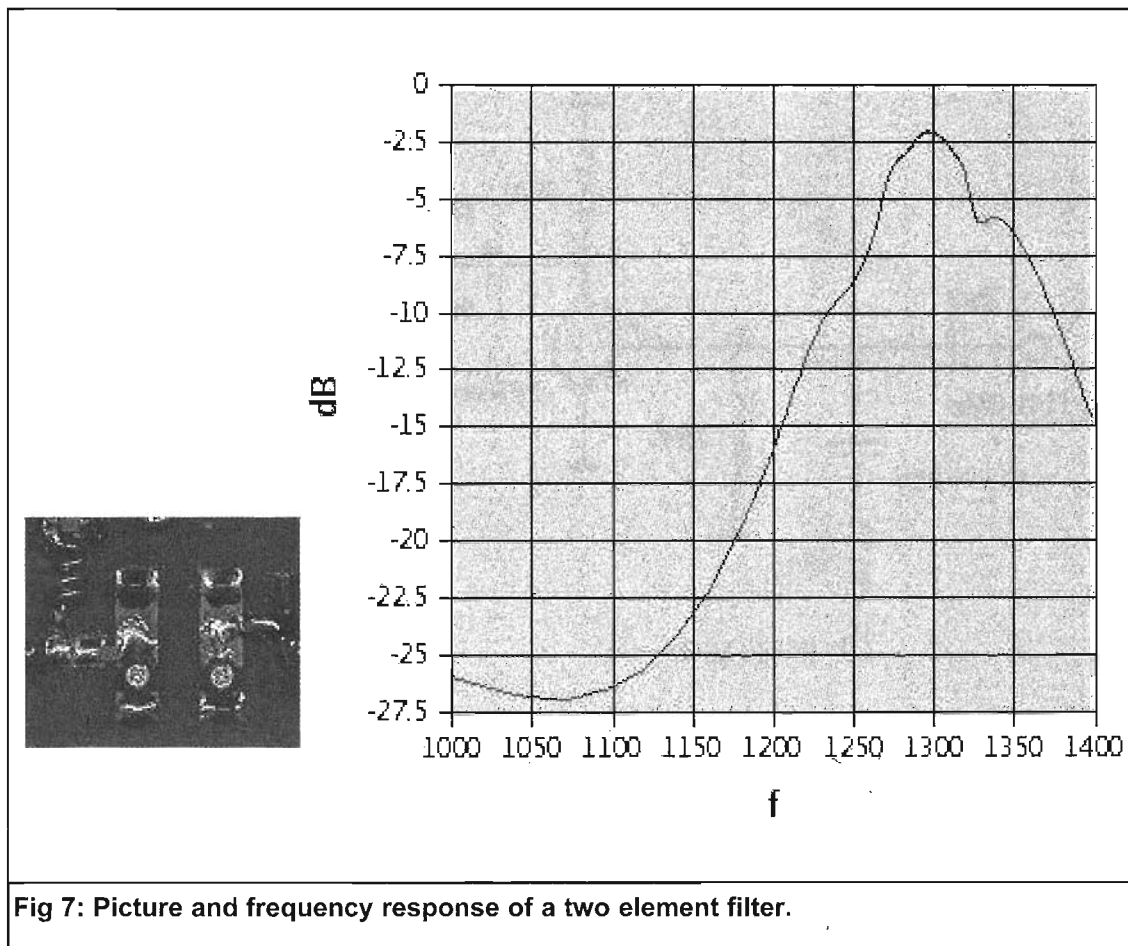

Fig 7: Picture and frequency response of a two element filter.

Locked Loop (PLL). An LO could also use both of these techniques. The first criteria for an LO is that it should be as coherent as possible, i.e. its output frequency should be a single frequency with low phase noise. The second criterion is to be stable in frequency with regard to variations in ambient temperature. Since an LO consists of many building blocks, this article will not cover the topic in more detail.

Filters

The classic UHF filters for amateur radio designs consist of printed circuit transmission lines with electrical lengths of less than one quarter of a wavelength, grounded at one end and tuned with a trimmer capacitor at the other. Several such resonant elements are placed parallel with some millimetres spacing. This is commonly known as an interdigital filter. More recently some space saving solutions using expensive and hard-to-find ready-made resonators have been proposed, but the classical interdigital filter is still popular. It is also an economical solution since the lines are etched and the small trim capacitors needed are available for around one Euro

each. The use of surface mount capacitors is recommended since leaded capacitors have high inductive reactance at UHF. Fig 7 shows a picture of a two element filter, together with its approximate frequency response when carefully tuned. Note the insertion loss of some 2dB. The board material is 1.6mm FR4.

In order to calculate the line length and capacitance required it should be noted that the reactance of an end grounded stripline can be calculated with the following formula:

$$Z_l = jZ_0 \tan \frac{2\pi y}{\lambda} \quad (2)$$

where:

- j is the imaginary unit
- Z_0 is the characteristic impedance of the line
- λ the effective wavelength
- y the effective strip length

Note: Remember to have your calculator set to radians when typing the tan expression.

If a trimmer capacitor of a few pF is available, it is then a simple task to calculate the length of a stripline that would give an inductive reactance of the same magnitude. Remember the relation for capacitive reactance:

$$Z_c = \frac{-j}{2\pi f C} \quad (3)$$

By setting $Z_l = -Z_c$ then:

$$\frac{y}{\lambda} = \frac{\arctan \frac{1}{Z_0 2\pi f C}}{2\pi} \quad (4)$$

Note that the mechanical length of a stripline is shorter than the corresponding electrical length in free space due to a dielectric constant, ϵ_r , higher than unity. By compensating for this we get the formula:

$$x = \frac{c}{2\pi f \sqrt{\epsilon_r}} \arctan \frac{1}{Z_0 2\pi f C} \quad (5)$$

where:

- c is the speed of light (3×10^8 m/s)
- x is the mechanical length of the line

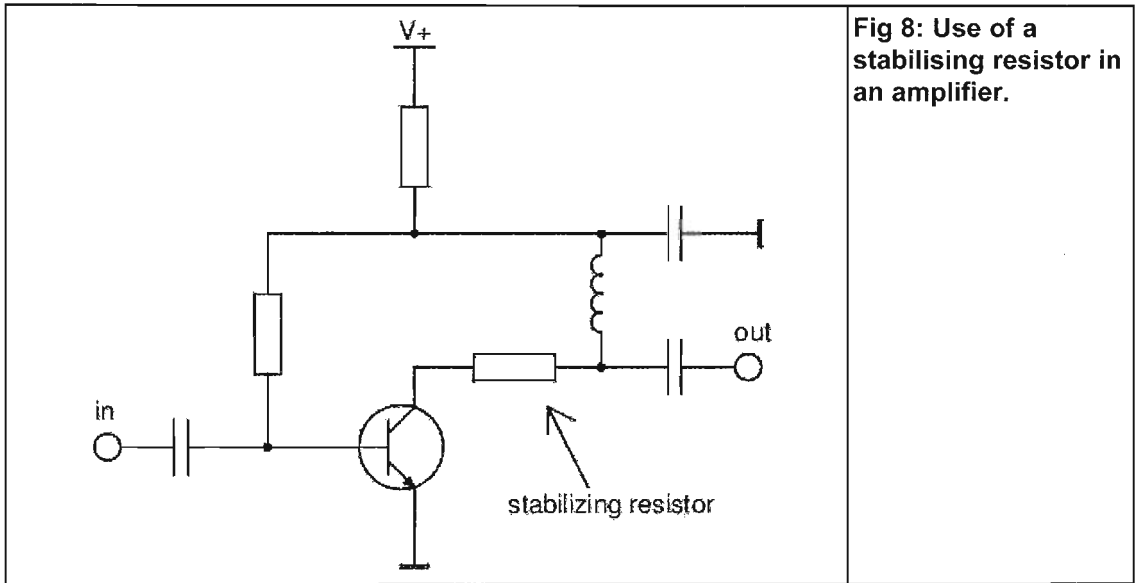

Fig 8: Use of a stabilising resistor in an amplifier.

In order to choose a suitable characteristic line impedance we use this relation:

$$Z_0 = \frac{87}{\sqrt{\epsilon_r + 1.41}} \ln \frac{5.98H}{0.8W + T} \quad (6)$$

where:

- H is the board thickness
- W the width of the line
- T the thickness of the copper (often negligible)

The filter in Fig 7 uses striplines with a Z_0 of 30Ω , corresponding to a width of 5mm on 1.6mm thick FR4 with $\epsilon_r = 4.7$, tuned with approximately 4pF. By using the equations above we find the mechanical length to be 14mm. Note that when the calculated length is short, it is a good idea to include the length of the trimmer capacitor.

Amplifiers

There are many bipolar transistors available with descent gain (7 - 13dB) that would make good small signal amplifiers on 23cm. These range from the older BFR91, BFR34 to the descendants like BFR93A, BFR520 and other modern devices in SMD packages with higher gain and less noise. There are also new bipolar transistors with very high transition frequencies ($f_t > 20\text{GHz}$) which show very low noise and high gain at a few GHz. But to construct an amplifier stage for 1.3GHz is not a simple task. A rule of thumb is that the gain of a transistor decreases at 6dB per octave. This means that a transistor with 10dB gain at 1GHz has around 22dB at 250MHz and that one has to take this into consideration when designing an amplifier. Otherwise it might

easily turn into an oscillator. When using devices with very high gain like GaAs FETs or high f_t Si or SiGe bipolar transistors, it is in general a very good idea to decrease the gain at all frequencies by placing a resistor at the drain or collector as shown in Fig 8. This could be of a value of 10Ω to 50Ω or so.

If either a very low noise figure or high output power is not needed, it might be a good idea to use an MMIC amplifier. Such devices are often unconditionally stable, which means that they do not oscillate at any frequency if no external feedback network is present. This is often not the case for a high gain transistor that might burst into spurious oscillation if the impedances connected are not chosen with care.

The experimenter should also know that modern devices intended for small signal amplifiers are specified with S parameters. These are measurements of the reflection coefficients at the different ports of the device when terminated with 50Ω . The parameters are most often fed into a computer program for modelling and simulation of the device. A complete understanding of S parameters requires some knowledge in mathematics and transmission line theory, but fortunately one doesn't have to know all about them to use them. There are many books available covering the topic, [2] is one that is suitable for the amateur. When reading tables of S parameters for some device, the S_{21} parameter is often the most interesting one. It describes the complex forward transfer reflection coefficient, and by taking $20\log |S_{21}|$, where $|S_{21}|$ is the value of the parameter (not the angle), one gets the gain in dB at the frequency of interest when the source and load impedances are both 50Ω .

Switches and capacitors

In order to use building blocks for both TX and RX, one has to use switches of some kind. When it comes to connecting the antenna to the RX and TX amplifiers (switch 1 in Fig. 1), a coaxial relay is in general a very good choice since it has minor loss and can handle high power levels. But such a relay is expensive and occupies space. Therefore it is a better choice to use PIN diodes for switches where the loss is less critical (like for switch 2 in Fig 1). What is so special about PIN diodes is that they are slow enough not to rectify an RF signal and at the same time have small junction capacitances. But their main drawback is that they always have several Ohms of forward resistance that can result in a loss in the order of a dB for a simple switch. The fact that a PIN diode also has poor isolation, i.e. attenuation when it is turned off, would suggest that a simple mechanical relay might be a better choice for the switches 4 and 5 in Fig. 1. A small relay usually works fine at VHF.

Another thing the designer should be aware of is the loss in capacitors at high frequencies. Apart from dielectric loss this is caused by the low self-resonance frequency of standard capacitors. For instance a 100pF 0805 SMD type ceramic capacitor is not really a capacitor at 1296MHz , it behaves as an inductor and a resistor in series. A loss of 0.3dB was measured for such a device. According to [3], a 0805 capacitor has a series inductance of some 1.5nH and this would suggest that 10pF would be a better value in order to minimise reactive loss.

10GHz Transverter from Surplus Qualcomm OmniTracks Units

This article was written by Kerry Banke, N6IZW of the San Diego Microwave Group and presented at The Microwave Update in 1999. It offers an economical route to 10GHz with the parts still available when this book was produced in 2003. The unmodified transceiver, 10MHz TXCO and unmodified 1 watt PA can be ordered from Chuck Houghton for about £100 [4].

Overall Concept and Design

An earlier Qualcomm X-Band conversion project required considerable mechanical as well as electrical modifications and was based on replacing the original stripline filters with pipecap filters. The pipecap filters were required to provide sufficient LO and image rejection at 10GHz that the original stripline filters could not provide for a 2m IF. This version uses a somewhat smaller, more recent OmniTracks unit that contains the power supply and synthesiser on the same assembly as the RF board and utilises dual conversion high side LO to allow use of the stripline filters. The filter modification has been proven to work well by extending the filter elements to specified lengths. Some additional tuning of the transmit output stages appears to be required for maximum output.

The synthesiser VCO operates at 2,272MHz which, when multiplied by 5, becomes 11,360MHz for the first LO. The first IF frequency is 992MHz which is near the original internal IF frequency of 1GHz. The second LO is derived from the synthesiser pre-scaler, this divides the VCO

3216 PLL Calculations for X Band Transverter with 144MHz 2 nd IF						1 st LO=11,360MHz 1 st IF=992MHz		
Ref MHz	2	Ref MHz can be 10MHz divided by any integer from 1 - 16						
VCO MHz	2,272							
PLL MHz	1,136	PLL in MHz is VCO/2 and must be an integer multiple of Ref MHz						
N	568							
		M6(Pin15)	M5(Pin14)	M4(Pin13)	M3(Pin10)	M2(Pin9)	M1(Pin8)	M0(Pin7)
M	55	0	1	1	0	1	1	1
Board as is		0	0	0	0	0	0	0
		A3(Pin21)	A2(Pin20)	A1(Pin19)	A0(Pin18)			
A	8	1	0	0	0			
Board as is		0	0	0	0			
		R2(Pin5)	R2(Pin4)	R1(Pin3)	R0(Pin2)			
R	4	0	1	0	0			
Board as is		0	0	0	0			
Lift pin22								
Reference suppression filter modifications, parallel these capacitors with the following values								
Ref MHz	C1	C2,C3	Add 1pF to VCO					
5	None	None						
2	1000pF	3000pF						
1	4700pF	6800pF						

Fig 9: Synthesiser calculations.

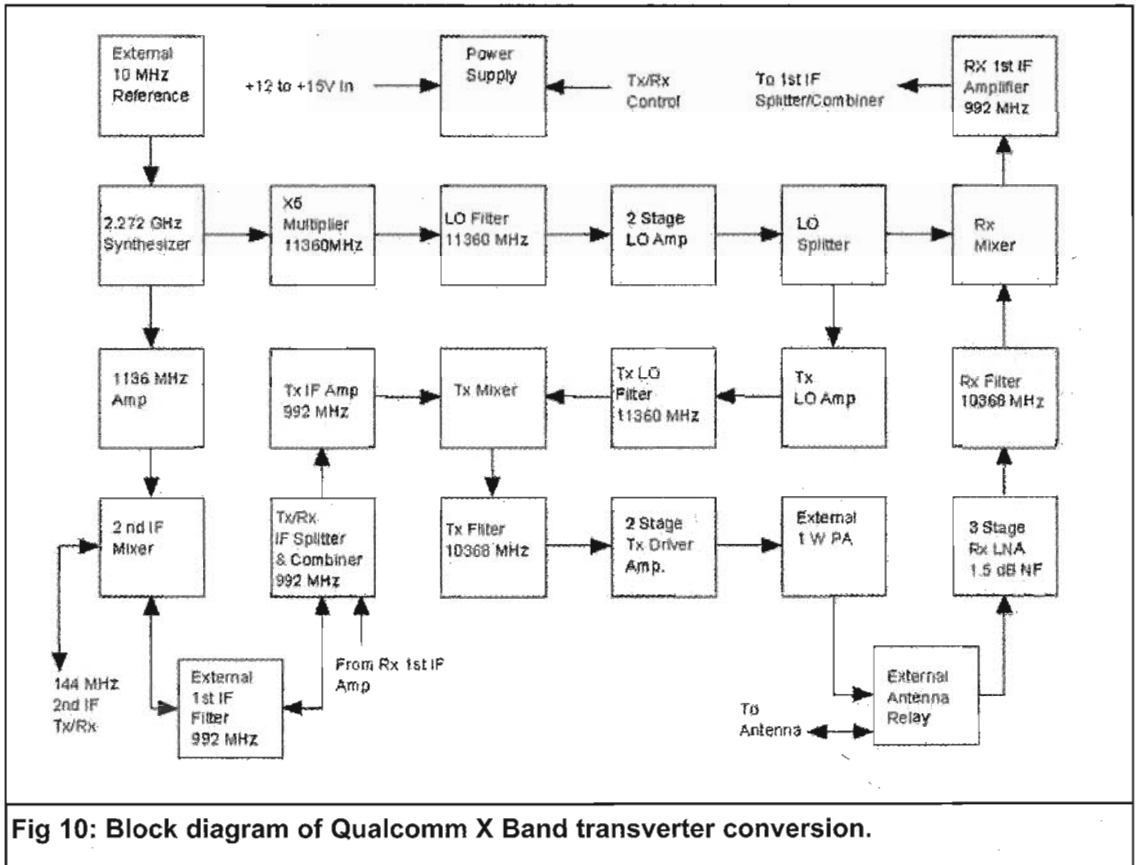

Fig 10: Block diagram of Qualcomm X Band transverter conversion.

frequency by 2 to produce 1,136MHz. Other second IF frequencies may be calculated using the relationship $(RF-IF2)/0.9 = LO1$ where RF is the 10GHz operating frequency (10,368MHz), IF2 is the second IF frequency, and LO1 is the first LO frequency. The synthesiser output frequency is then LO1 divided by 5. Fig 9 shows the Excel spread sheet used to calculate the synthesiser programming.

The second conversion stage consists of a second LO amplifier (1,136MHz) and SRA-11 mixer converting the 992MHz 1st IF to the 144MHz 2nd IF. A 992MHz filter is required between the two conversion stages. Both Evanescent Mode and Coaxial Ceramic filters have been used.

The conversion yields a reasonably high performance transverter with a noise figure of about 1.5dB and a power output of +8dBm, frequency locked to a stable 10MHz reference. Power required is +12VDC with a current consumption of about 0.5 amps in receive and 0.6 amps in transmit (about 1.5 amps total in transmit when including the 1 watt PA).

Fig 10 is a block diagram of the modified unit. The unmodified circuit has a synthesiser output of 2,620MHz providing an LO of 13.1GHz. The original transmit frequency was around 14.5GHz with 1 watt output, and the receiver was near 12GHz. Unfortunately the integrated PA in the original configuration provides no useful output below 12GHz and is not modifiable and so has been removed for the 10GHz conversion. The transmit and receive IF preamplifiers make the transmit input requirement low (-10dBm) and provides high overall transverter receive gain.



Fig 11: Picture of the modified Qualcomm transverter.

Fig 11 shows a picture of the modified transverter, 1 watt amplifier and 10MHz TCXO. Fig 12 shows a picture indicating the locations of the various functions.

The following is an outline of the conversion procedure:

1. Marking location of RF connectors and removal of circuit boards.
2. Base plate modification for mounting two SMA connectors (10GHz receive and transmit) plus four SMA connectors installed (2 RF + 1 IF and 10MHz Reference input).
3. Clearing of SMA connector pin areas in PCB ground plane.

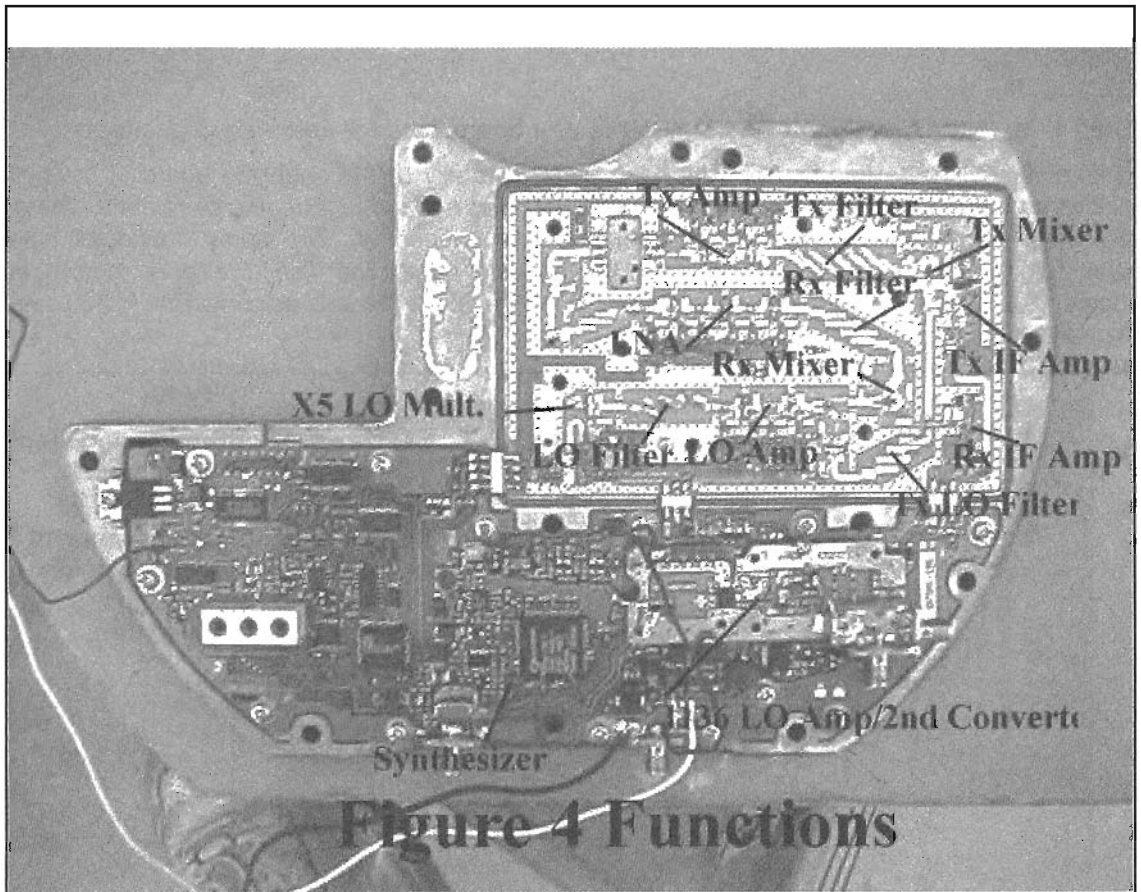

Fig 12: Picture of Qualcomm transverter showing various functions.

4. Remounting of PCBs.
5. Cuts made to PCB and coupling capacitors installed.
6. Stripline filter elements extended and tuning stubs added.
7. Synthesiser reprogrammed and 4 capacitors added.
8. Add tuning stubs to the x5 Multiplier stage
9. 2nd LO amplifier, mixer and 1st IF filter added.
10. Power and transmit/receive control wires added.
11. Test of all biasing.
12. Synthesiser and receiver test.
13. Transmitter test and output stage tuning.

Conversion procedures

Step 1. Mark the location of RF connectors and board cuts for coupling capacitors.

Before removing the boards from the base plate, carefully drill through the board in the two places shown using a 0.050 inch diameter drill just deep enough to mark the base plate. These are the locations for receive and transmit RF SMA connectors. The upper connector hole (transmit) is located 0.5 inches to the left of the transistor case edge. The lower hole (receive) is located 0.4 inches to the left of the transistor case edge. Make the cuts as shown in Fig 13 using a sharp knife.

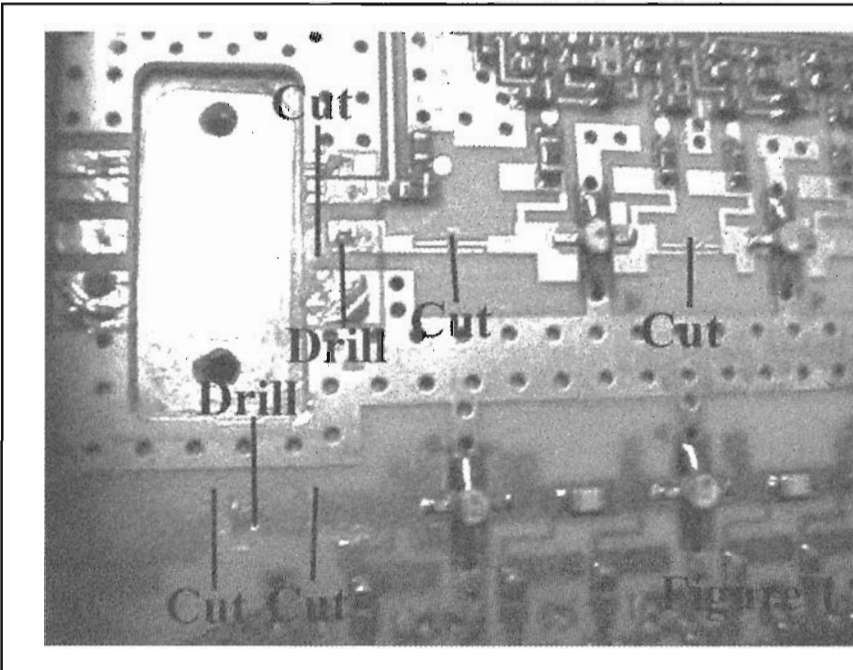

Fig 13:

Conversion step 1, mark the location of RF connectors and board cuts for coupling capacitors.

Step 2. Base plate removal, modification, and connector installation.

After making the holes and cuts, remove all screws and lift the boards off of the base plate. (Note: the original antenna connector pin must be de-soldered to remove the board. Once the boards are removed, drill through the plate in the 2 locations marked using a 0.161 inch drill to clear the teflon insulator of the SMA connectors. Use a milling tool to remove enough material on the back side of the base plate (see Fig 14) to clear the two SMA connector locations, taking the thickness down to about 0.125 inches (may vary depending on available SMA connector pin length). Locate, drill and tap the base plate for two 2-56 mounting screws at each connector. Mount the SMA connectors on the base plate and cut the Teflon insulator flush with the top side of the base plate (circuit board side). Carefully clear the ground plane around the two connector holes on the bottom side of the circuit board to prevent the SMA probe from being shorted (using about a 0.125 inch drill rotated between your fingers). Reinstall the circuit boards onto the base plate.

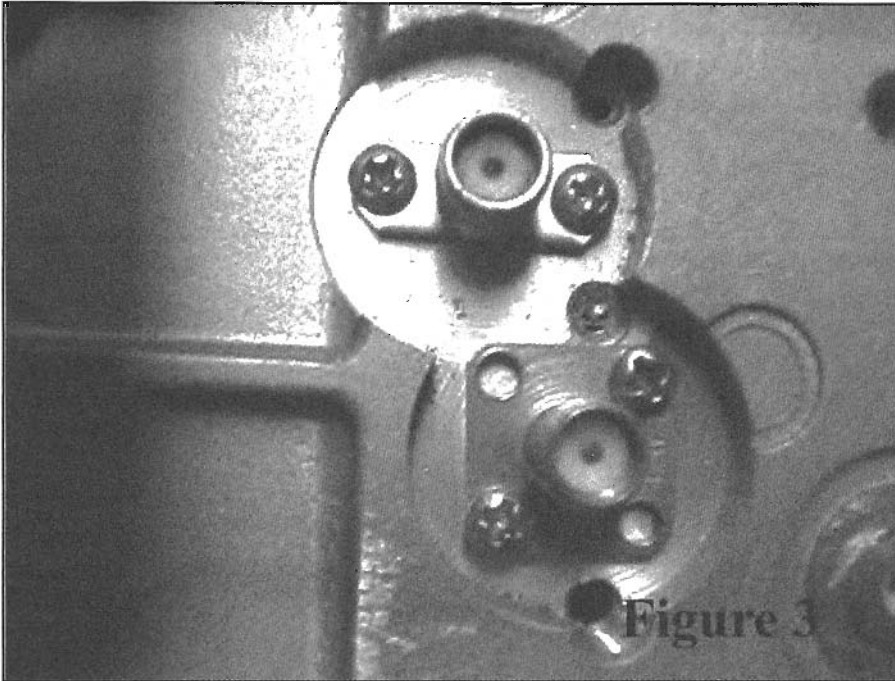

Fig 14:
Conversion step 2, base plate removal, modification, and connector installation.

Step 3. Add coupling capacitors

Add the 3 capacitors along with the additional microstrip pieces to modify as shown in Fig 15.

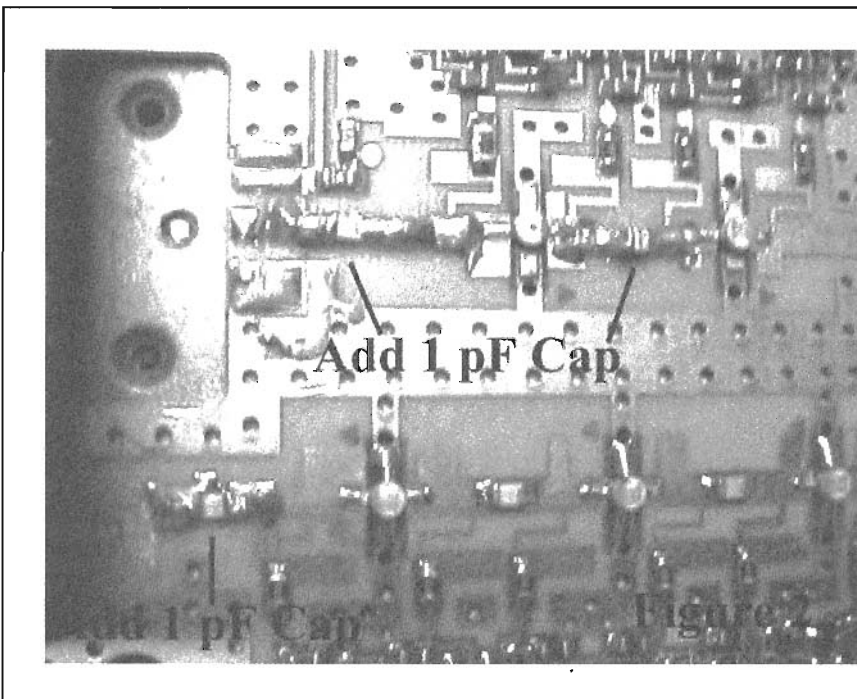

Fig 15:
Conversion step 3, add coupling capacitors.

Microwave Projects

Step 4. Extend the transmit LO filter elements to the total length shown in Fig 16.

Filter extensions are made by cutting 0.003 - 0.005 inch copper shim stock into strips about 0.07 inches wide and tinning both sides of the strip shaking off excess solder. No additional solder is normally needed when attaching the extensions as the tinning re-flows when touched by the soldering iron. The length of the top element (0.21 inches) is measured between the marks as shown.

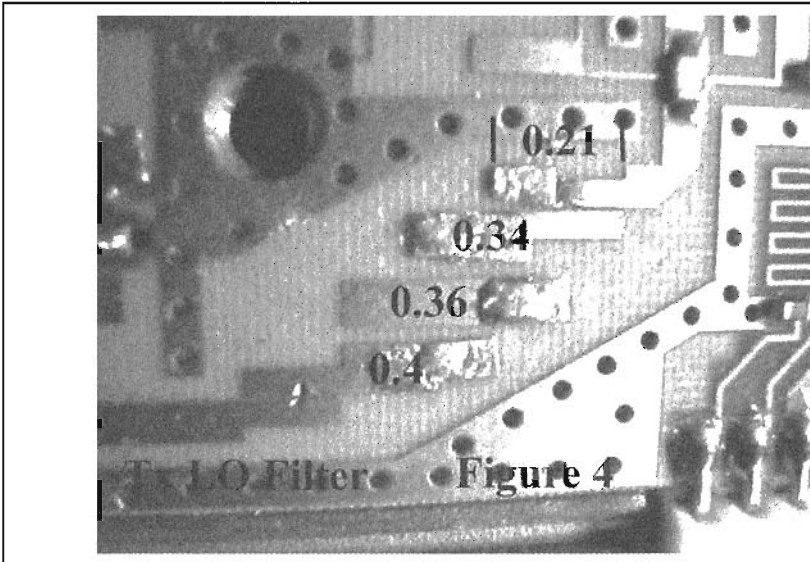

Fig 16:

Conversion step 4, extend the transmit LO filter elements.

Step 5. Extend the LO filter elements as shown in Fig 17.

Again, total element lengths are shown except for the right-most element that has additional dimensions.

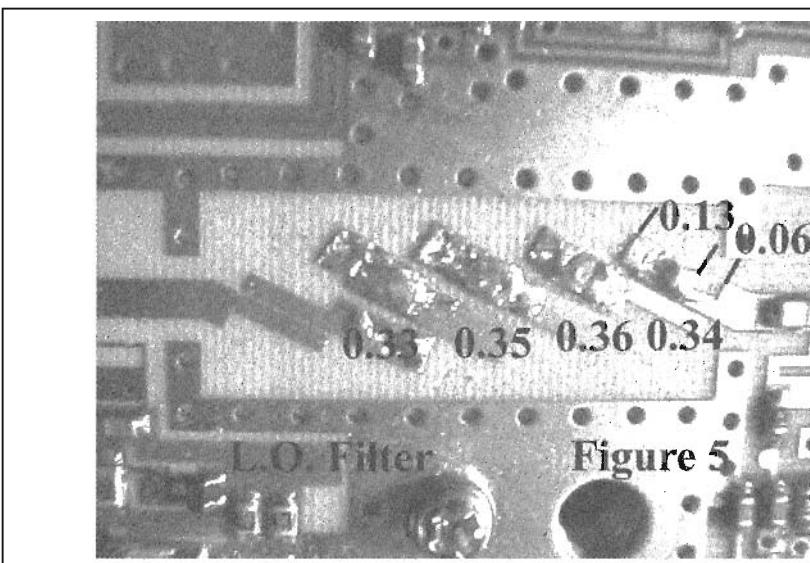

Fig 17:

Conversion step 5, extend the LO filter elements.

Step 6. Extend the receive filter elements as shown in Fig 18.

Dimensions shown are total element length.

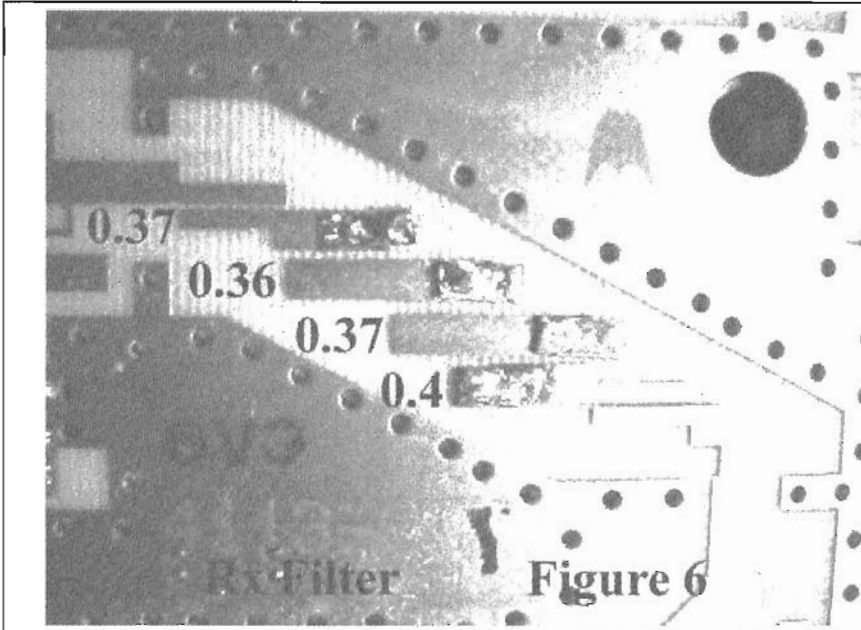

Fig 18:
Conversion step 6, extend the receive filter elements.

Step 7. Extend the transmit filter elements as shown in Fig 19.

Dimensions shown are total element length.

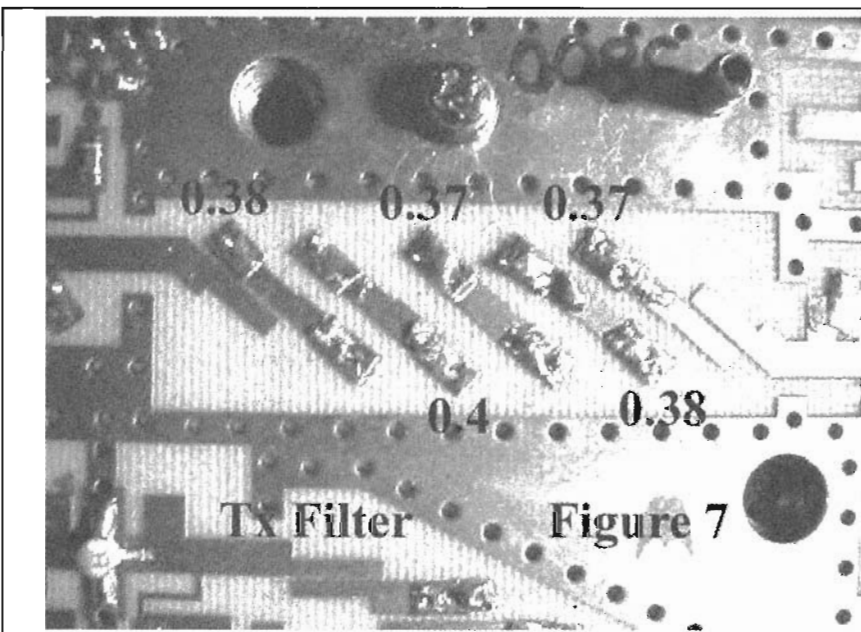
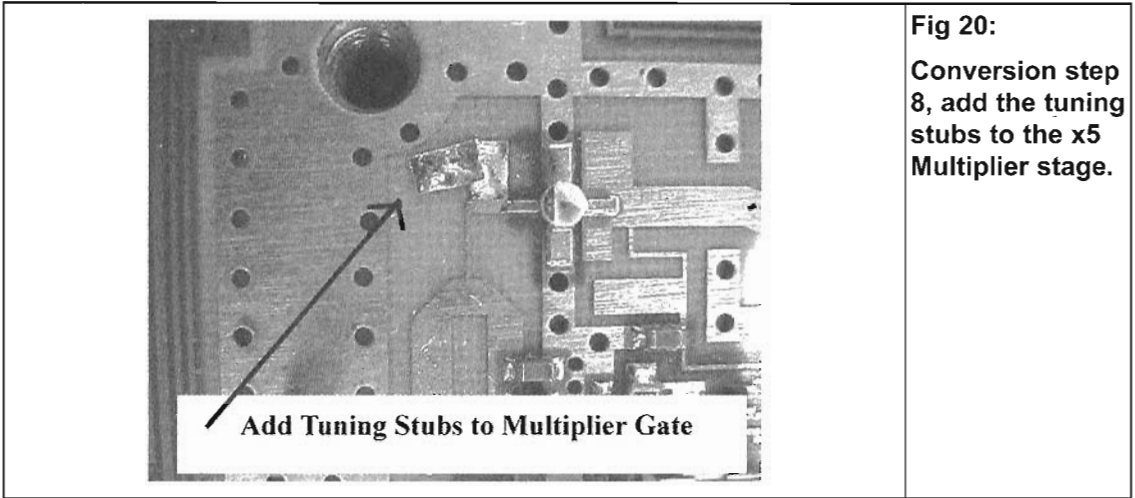

Fig 19:
Conversion step 7, extend the transmit filter elements.

Microwave Projects

Step 8. Add the tuning stubs to the x5 Multiplier stage.

This stage is located directly to the left of the LO filter which is shown in Fig17. The gate of the x5 Multiplier stage requires addition of two stripline stubs, as shown in Fig 20.



Step 9. Modify the 2nd LO amplifier board

Modify the 2nd LO amplifier board, mount onto transverter and connect 1,136MHz LO input through 1pF coupling capacitor as shown in Figs 21 - 23. Fig 21 shows the overall second IF converter which is mounted using two grounding lugs soldered to the top edge of the LO

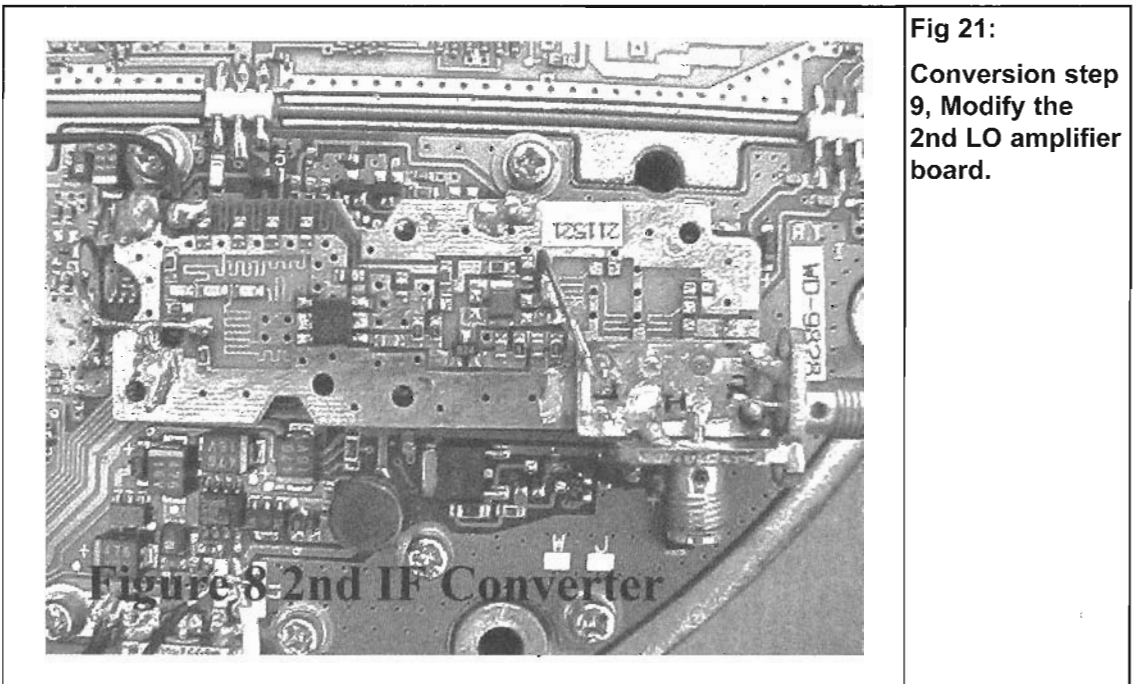

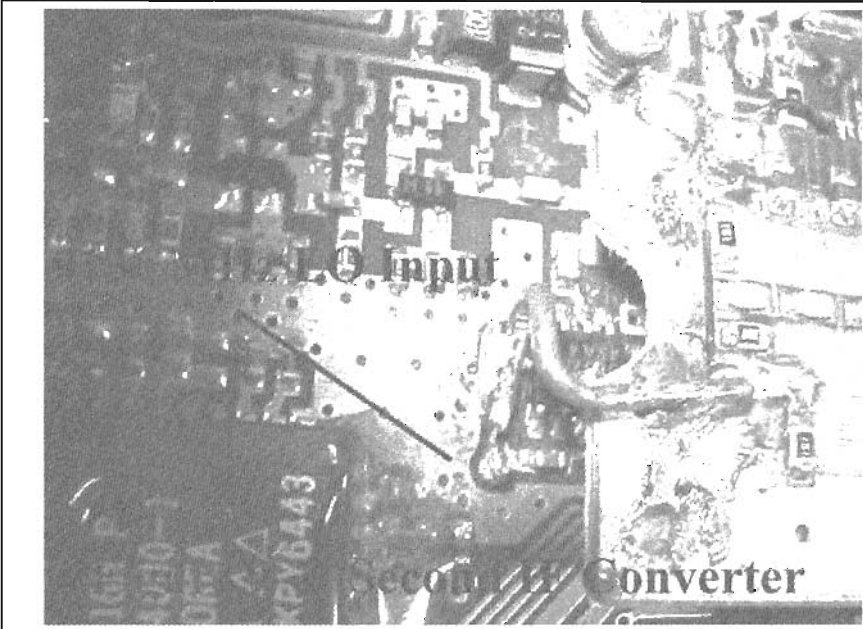

Fig 22:
Conversion step 9, Modifying the 2nd LO amplifier board. Showing coax connected to the 1,136MHz point on the synthesiser via a 1pF capacitor.

amplifier board and secured by two of the screws which mount the main transverter board. Fig 22 shows the coax connected to the 1,136MHz point on the synthesiser through a series 1pF capacitor. Fig 23 shows the mounting and wiring of the SRA-11 mixer onto the LO amplifier board. Note the cut on the original amplifier output track after the connecting point to the mixer. The mixer case is carefully soldered directly to the LO amplifier board ground plane. The IF SMA connectors are mounted by carefully soldering them directly to the top of the mixer case.

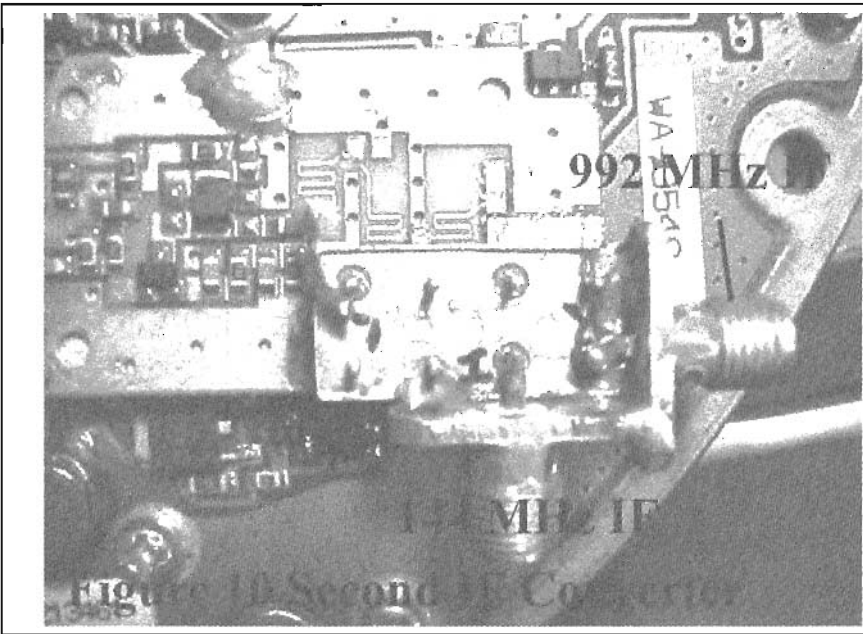

Fig 23:
Conversion step 9, Modifying the 2nd LO amplifier board. Showing the mounting of the SRA-11 mixer.

Step 10. Program the synthesiser

Program the synthesiser as shown in Fig 24 by carefully lifting the pins shown with a knife. Ground pin 10 connecting it to pin 6 that is ground. Add the two 3000pF and 1000pF in parallel with the existing reference filter capacitors as shown in Fig 25.

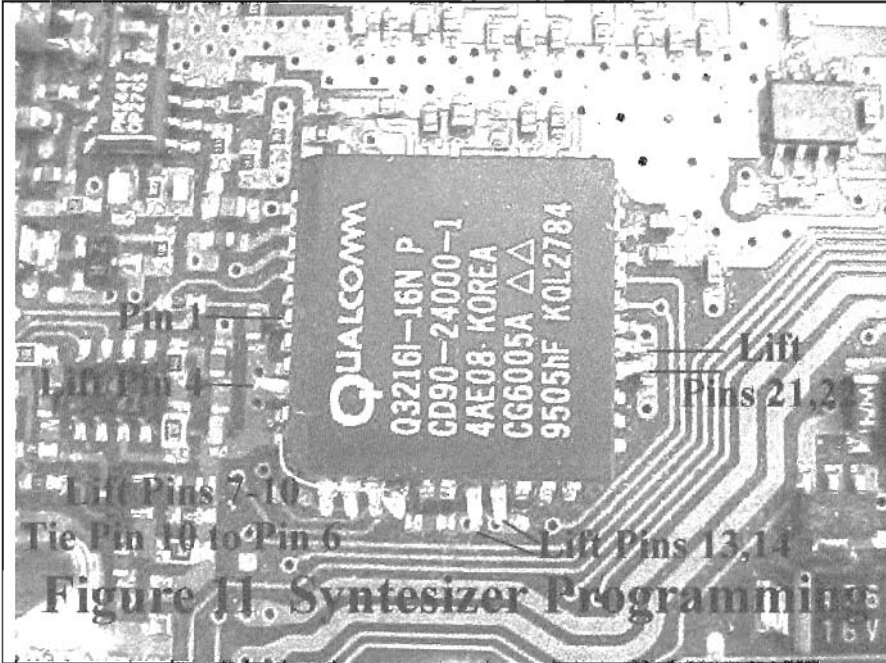

Fig 24:
Conversion step 10, program the synthesiser.

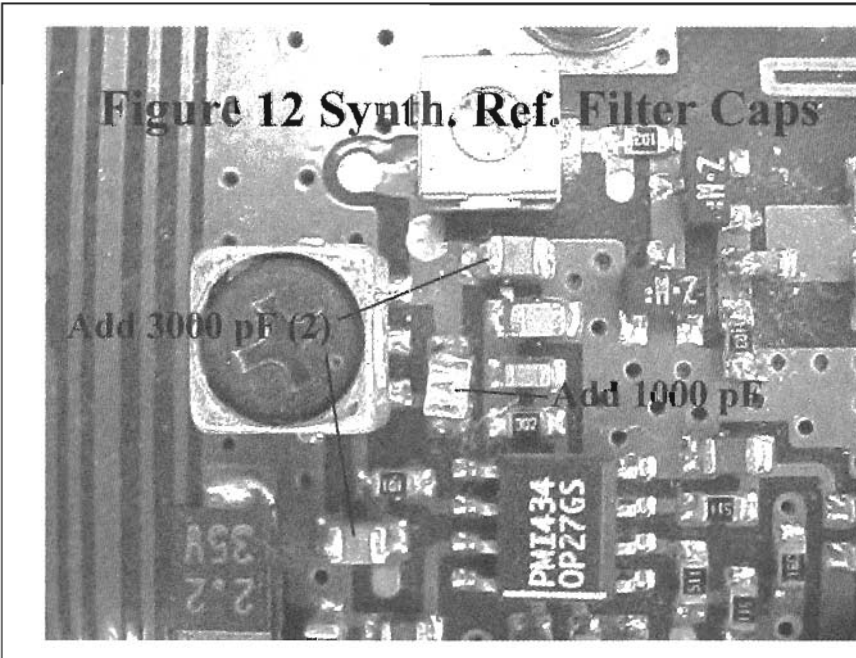

Fig 25:
Conversion step 10, adding capacitors to the reference filter.

Step 11. Lower the VCO frequency

Add a 1pF capacitor as shown in Fig 26 to lower the VCO frequency

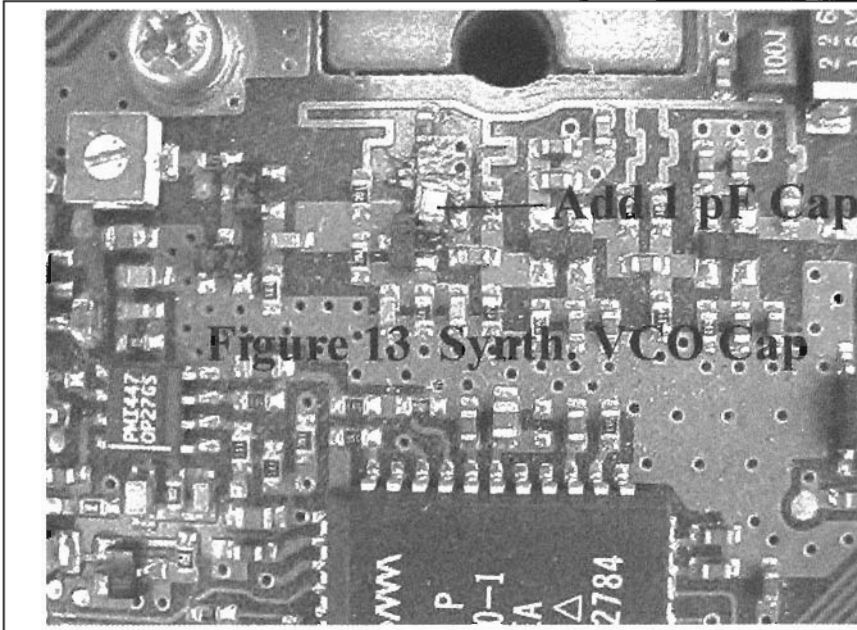

Fig 26:
Conversion step 11, lower the VCO frequency.

Step 12. Add transmit mixer tuning stubs

Add three transmit mixer tuning stubs as shown in Fig 27.

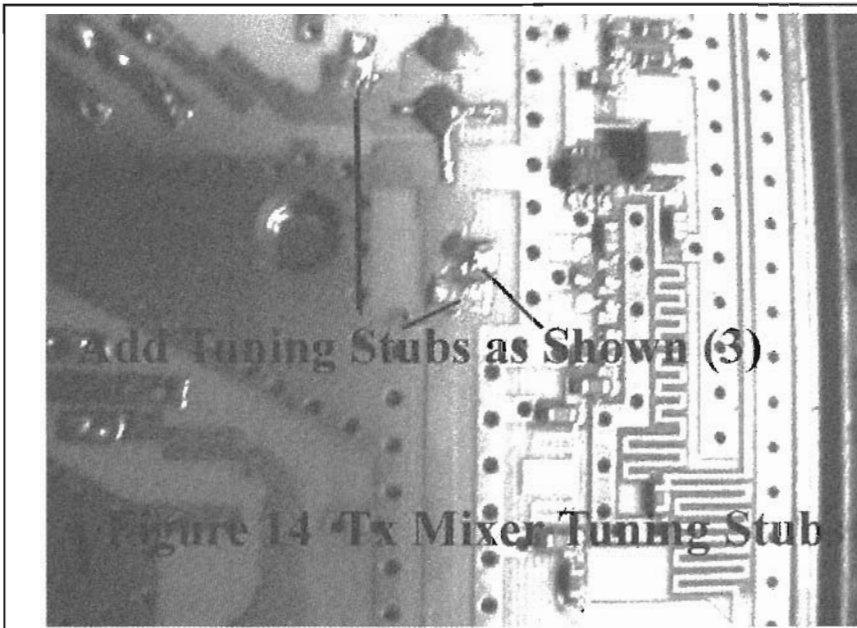

Fig 27:
Conversion step 12, add transmit mixer tuning stubs.

Microwave Projects

Step 13. Transmit/receive control

The transmit/receive control is connected as shown in Fig 28. Grounding the control line places the transverter in transmit mode. The control can be open or taken to +5v to place the transverter in receive mode.

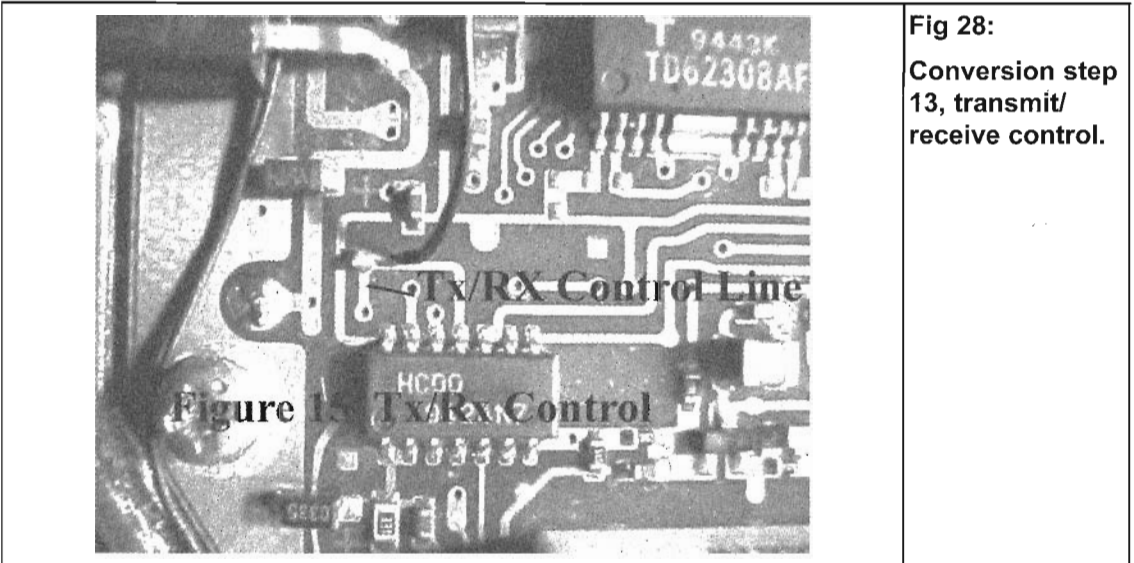

Fig 28:
Conversion step
13, transmit/
receive control.

Step 14. Power input

The +12VDC power input is connected to the point as shown in Fig 20. The original air core coil with one end connected to that point has been removed from the board. (This choke was originally used to supply +12V to the transverter through the 1st IF port).

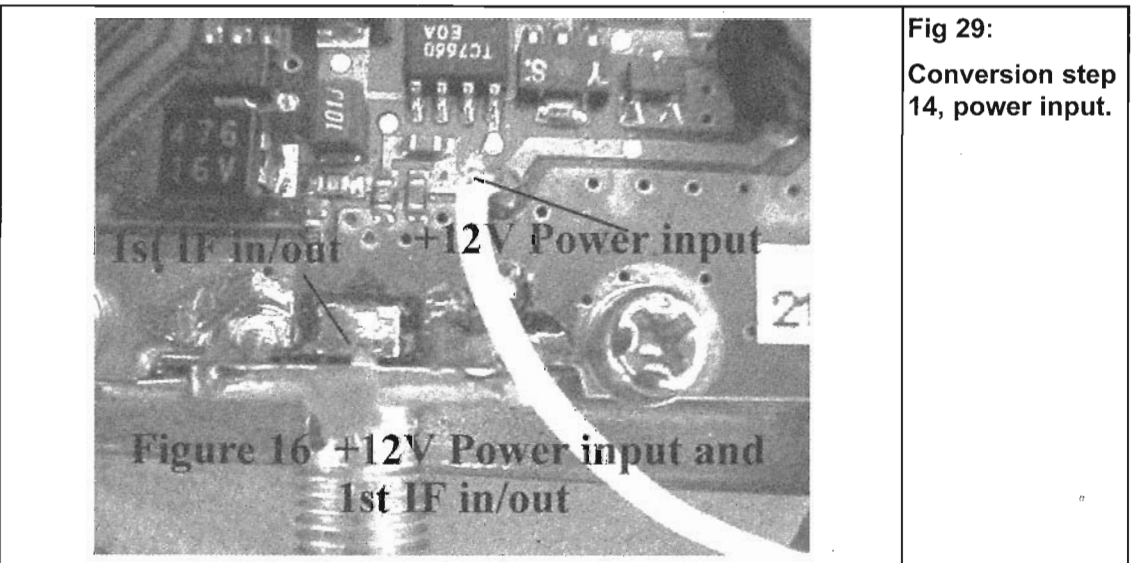

Fig 29:
Conversion step
14, power input.

Step 15. Powering up the Transverter.

Apply +12V to the power connector and verify that the current draw in receive mode is about 0.5 amps. Connect the 10MHz reference to the transverter board. Pin 43 of the synthesiser IC should be high when locked. If available, use a spectrum analyser to check (sniff using a short probe connected by coax) the synthesiser output frequency and spectrum. The synthesiser should be operating on 2,272MHz and no 2MHz or other spurs should be visible. Carefully probe the drain of each FET in the LO multiplier, LO amplifier, and LNA to verify biases are approximately +2 to +3VDC. A drain voltage of near 0V or 5V probably indicates a problem with that stage. Place the transverter in transmit mode and verify the biasing on the transmit LO amplifier and transmit output amp stages.

Tune the 992MHz 1st IF filter (not part of the transverter board) and connect it between the 1st IF ports on the transverter board and second IF converter. The receiver noise level at the 2nd IF port on the 2nd converter should be very noticeable on a 2m SSB receiver.

A weak 10,368MHz signal can then be connected to the receiver RF input connector and monitored on the 2m SSB receiver. The overall gain from receiver RF input to 2nd IF output should be roughly 35 to 45 dB.

Place the transverter into transmit mode and connect about 10dBm at 144MHz to the 2nd IF port. Monitor the power level at the transmit RF output port and add/move the transmit amplifier tuning stubs shown in Fig 27 as required for maximum output. Typical transmit output will be about + 8dBm. This is considerably more than required to drive the 1 watt amp to full power.

Conversion of 1 watt PA

These conversion notes were produced by Ken Schofield, W1RIL [6].

Many PA boards have been successfully re-tuned for 10GHz operation.

No two boards are exactly alike and each will tune a little different than its apparent twin. Fig 30 represents the board before tuning. The numbered steps in Fig 31 will in many cases get your PA up into the gain range stated. You will find that numbered step 3 to be the most sensitive to gain increase. Unfortunately it is also one of the "busiest" areas on the board - BE CAREFUL!

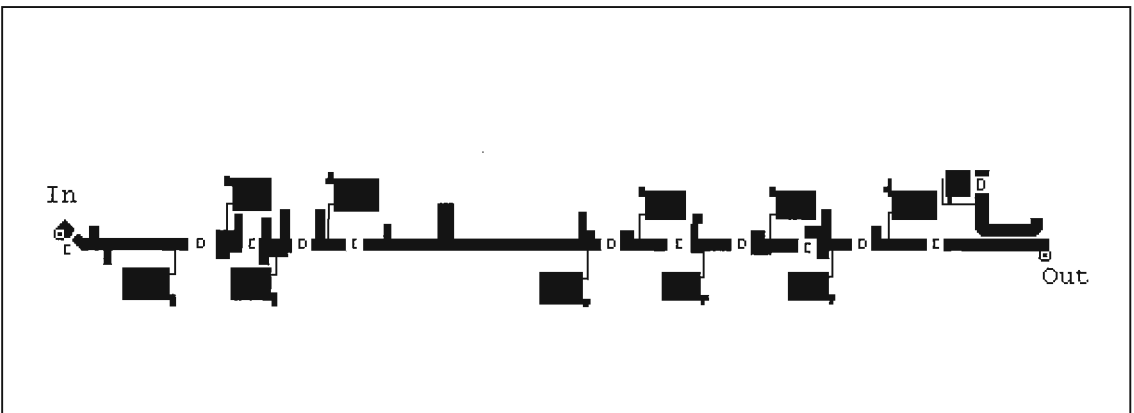

Fig 30: PA board prior to tuning. -15dbm input gives +5 to +10dbm output with 10 volts at approximately 1 amp.

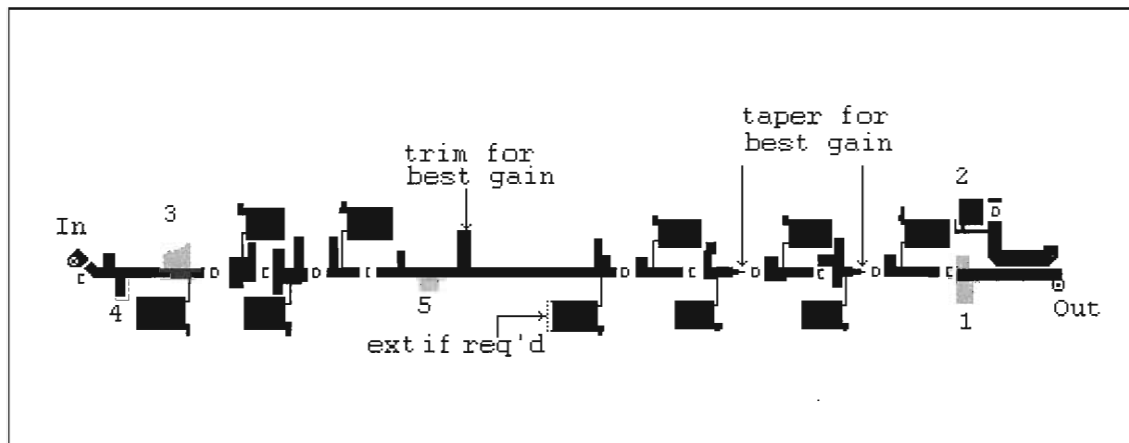

Fig 31: PA board after tuning. The shaded tabs were added and tuned in the sequence shown. Results vary slightly from board to board with the following three examples being typical:

- 10dbm input gives 30.8dbm output (1.2 watts)
- 9.6dbm input gives 31.4dbm output (1.38 watts)
- 14.5dbm input gives 31.4dbm output (1.38 watts)

Key for diagram

[= coupling capacitor

D = devices

Input coupled with 2pF

A few do's and don't's are shown to help you bypass some of the many pitfalls that can be encountered - many are obvious and have been stated before, but bear repeating.

Do:

- Use low voltage grounded soldering iron & work in a static free area.
- Check for negative bias on all stages prior to connecting Vcc voltage.
- Use good quality 50 mil chip caps - in and out approximately 1 to 2pf.
- Remove all voltages prior to soldering on board.

Don't:

- Work on board tracks when tired, shaky or after just losing an argument with the XYL.
- Touch device inputs with anything that hasn't been just previously grounded.
- Apply Vcc to any stage lacking bias voltage.
- Shoot for 45dB gain - you won't get it! Be happy with 25 to 30dB

A “building block” 5760MHz transverter design, Tom Mayo, N1MU

This transverter was designed on the fly using components easily found at Hamfests. The core is a Watkins-Johnson WJ-MY84 Doubly Balanced Mixer. This is a wideband mixer that works very well on the 5GHz Ham band. The transverter was constructed around the mixer in a building block fashion Fig 32.

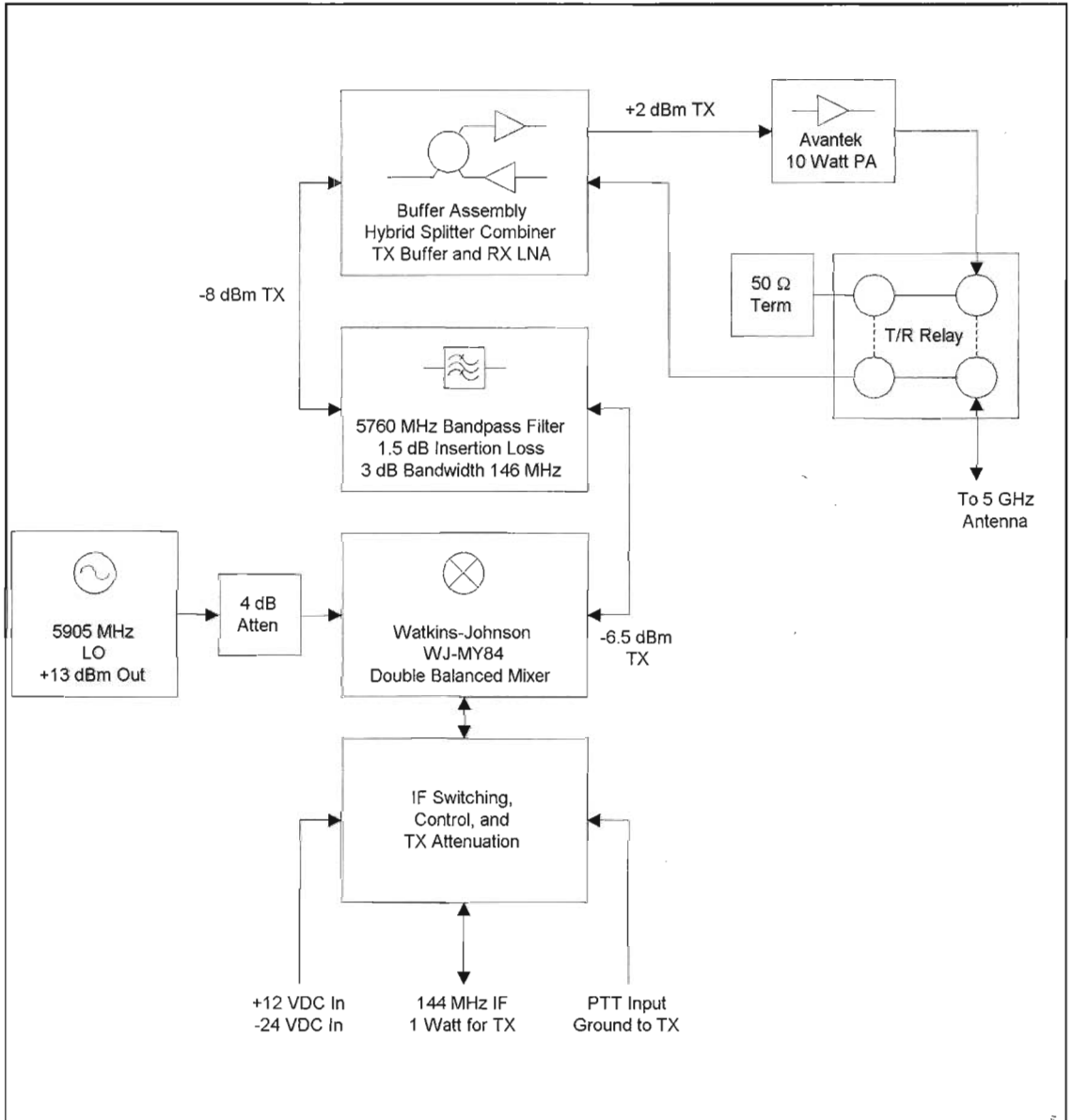

Fig 32: 5GHz transverter block diagram.

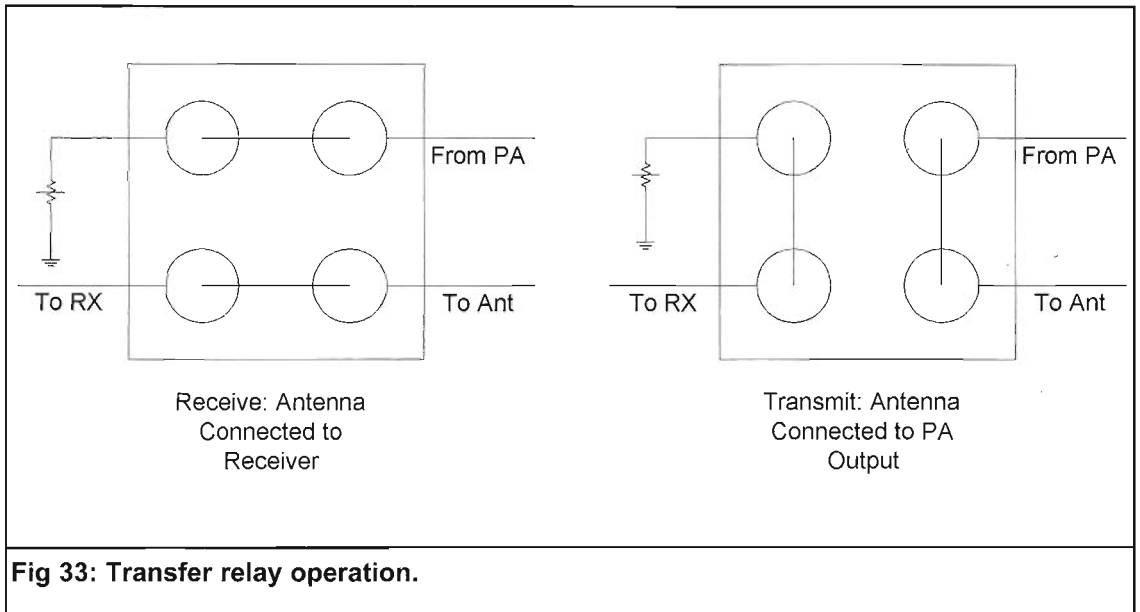

Fig 33: Transfer relay operation.

The 5905MHz Local Oscillator is a surplus brick type 6GHz oscillator that was re-crystalled and tuned. Because 5905MHz is closer to the specified operating range of the oscillator than 5616MHz, the transverter employs high side injection. The oscillator is powered by 20VDC generated by a negative voltage linear regulator in the IF Switching and Control unit. It is very important that this voltage be stable between transmit and receive, otherwise there is frequency offset or drift when switching. The LO puts out +13dBm, but the mixer requires only 9dBm nominally, so a 4dB attenuator is installed on the output of the oscillator.

The Watkins-Johnson WJ-MY84 is a Doubly Balanced Mixer. It operates over a wide frequency range that encompasses the 5GHz band. The LO and RF frequencies may fall between 1.8 and 10GHz, while the IF frequency may be from DC to 1GHz. Conversion loss is specified to be between 6.0 and 6.5dB at 5.7GHz.

To select only the desired mixer product of 5905 - 144MHz, a surplus 5GHz bandpass filter is employed. The filter was a component of a 6GHz Local Oscillator very similar to the one used as the LO in this transverter. It has a 146MHz bandwidth, and is tuned for a centre frequency of 5760MHz. This removes the unwanted mixer product 288MHz away ($5905 + 144\text{MHz}$) as well as any LO leakage from the mixer. The filter also removes unwanted receive energy before down conversion.

The Avantek power amplifier is of a type commonly found at Hamfests and is powered by -24VDC during transmit only. Typically, T/R relays do not provide enough isolation, so leaving a high gain power amplifier biased during receive can significantly raise the noise floor of the receiver, thereby swamping out the desired signal. Power Amplifiers such as the one used in this transverter put out around 10 Watts when driven with between 3 and +3dBm.

The Transmit/Receive Relay is also of a type commonly found at Hamfests. It has SMA connectors and employs a 28VDC coil. In this transverter, only -24VDC is available, and this is able to switch the relay without any problem. The relay is a transfer relay connecting the two

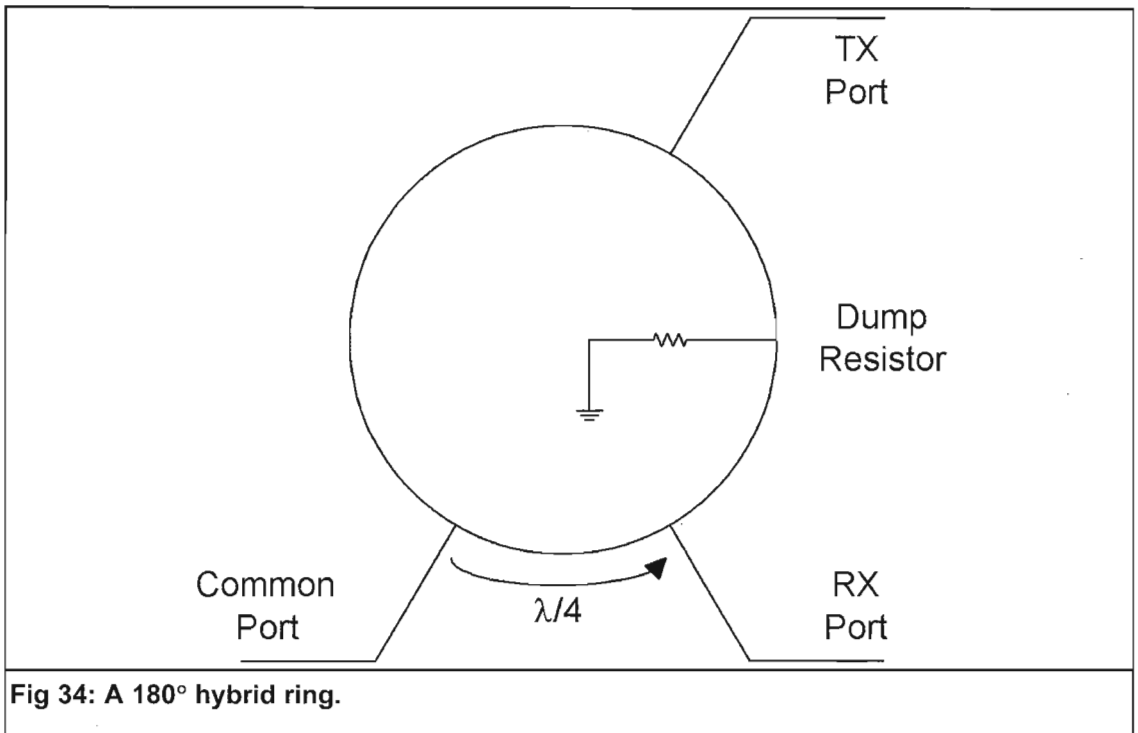

Fig 34: A 180° hybrid ring.

vertically aligned ports in one state and the horizontally aligned ports in the other. This allows the antenna to be connected to the PA output in transmit and the receive LNA in receive. A 50Ω dump (dummy) load is connected to the unused port in either state to present a clean impedance to the transmitter or receiver when not in use. The operation of the transfer relay is shown in Fig 33.

The building blocks in the transverter are joined with UT-141 semi-rigid coax where possible to ensure the attenuation is solid and consistent, very desirable at GHz frequencies.

The time-consuming parts of this transverter design are the IF Switching and Control Unit and the Buffer Assembly. The IF Switching and Control Unit of this transverter contains several subsections:

- -20VDC linear regulator
- PIN diode switched attenuator for IF T/R switching
- Relay and bias sequencer to prevent hot-switching the RF T/R relay
- Relay to remove 24VDC bias from the PA during receive

The PIN diode switch is implemented based on a design by Greg Raven, KF5N [7]. Dick Frey, WA2AAU, designed the sequencer.

The buffer assembly employs a printed circuit 180° hybrid ring to both couple the transmit power in from the bandpass filter and pass the receive signal out to the filter. This implementation of T/R “switching” on the low power side of the PA was selected due to its low cost as well as its

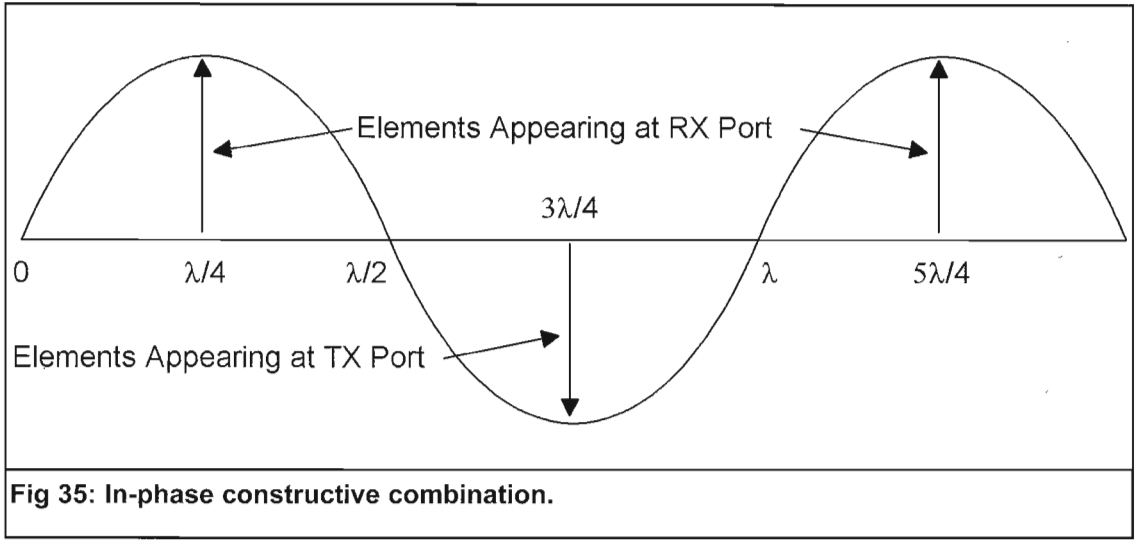

novelty. The idea for this came from an article on a 3GHz transverter by Zack Lau, then KH6CP/1, and now W1VT [8]. More information on hybrid rings can be found in an article on mixers by Bill Troetschel, K6UQH [9]. The hybrid ring is a $6/4$ wavelength ring at 70.7Ω as shown in Fig 34.

The ring acts as a power divider in the forward direction, and a combiner in the reverse direction. On transmit, the ring sends half of the input signal to the Minicircuits ERA-2 preamplifier and half into the output of the HP MGA86576 LNA. The ERA-2 has around 13dB of gain. Back-driving the LNA, with the level appearing after the hybrid ring, is within the allowed limits of the device. On receive, half of the signal from the LNA is directed to the bandpass filter via the common port, and half is directed to the dump resistor. Because the LNA has enough gain, this 3dB loss does not impair reception.

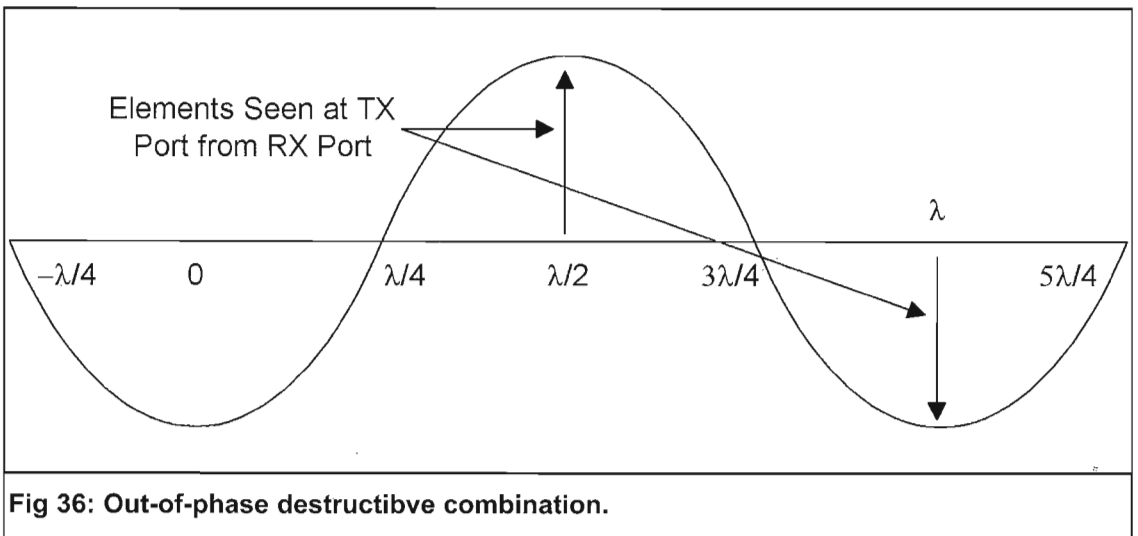

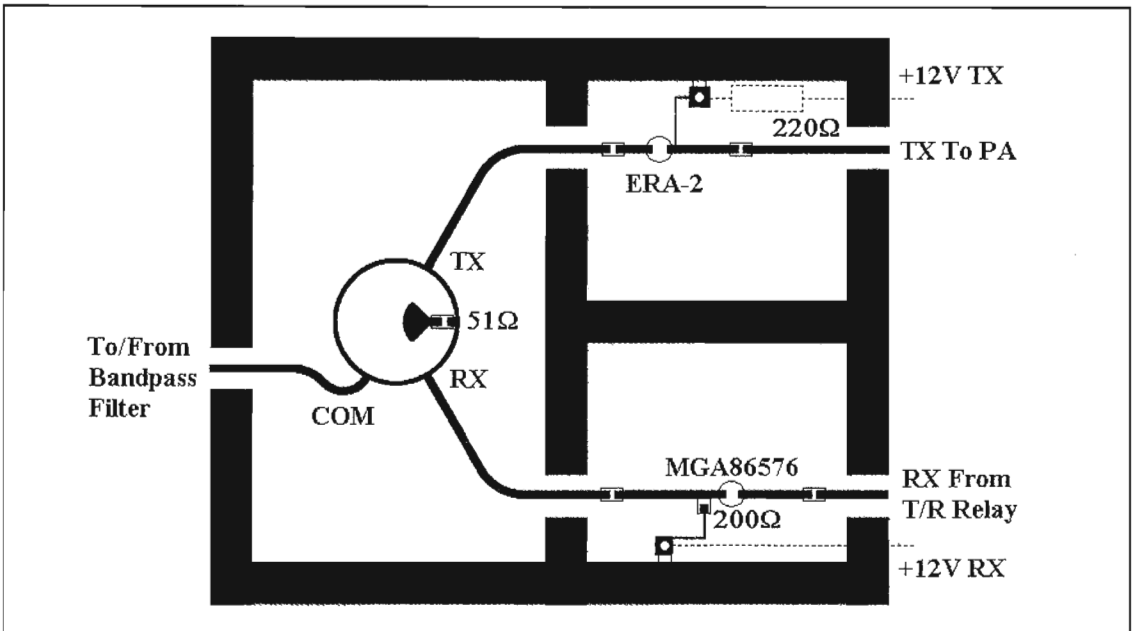

Fig 37: Buffer assembly layout for the 5GHz transverter.

To understand the hybrid ring, look at the phase plots in the Figs 35 and 36.

In Fig 35, the zero phase point represents the common port of the ring. Note that the $\lambda/4$ and $5\lambda/4$ points are in phase with each other (both positive). This represents the signal path between the Common port and the RX port each way around the ring. The two $3\lambda/4$ points (paths to the TX port) are obviously also in phase (both negative) because they are the same distance around the ring. Because signals are in phase in both directions around the ring at these ports, they add constructively.

In Fig 36, the zero phase point represents the RX port. Note that the $\lambda/2$ and the λ points (paths to the TX port) are out of phase and cancel, thus transferring no energy between these ports.

The hybrid ring was painstakingly designed for implementation on etched Rogers Duroid 5880 by analysing the desired dimensions and hand writing a Postscript representation. The substrate thickness and cladding thickness of the board used are 0.015" and 0.0014" respectively. Analysis begins with determining the wavelength of the desired signal.

$$f = 5.76 \times 10^9 \text{ Hz}$$

$$\lambda = 2.997925 \times 10^8 / f = 0.052047309 \text{ m}$$

To determine the circumference of the ring, the theoretical dimension is scaled by the velocity factor for a 0.025" (70.7Ω) trace.

Microwave Projects

$$C_{\text{ring}} = (6\lambda/4) \times 0.746124 / 0.0254 = 2.29333148 \text{ in}$$

To bias the ERA-2 and MGA86576, choke inductors are formed by printed circuit traces of 0.010" width. These traces are around 107Ω . The $\frac{1}{4}$ wavelength of these chokes is calculated using the velocity factor for 0.010" traces.

$$l_{\text{choke}} = (\lambda/4) \times 0.765386 / 0.0254 = 0.3921 \text{ in}$$

The printed circuit components of the design are joined together using 50Ω traces 0.046" wide. The dimensions were used to generate a hand written Postscript file exactly describing the layout of the Buffer Assembly. A representation of this artwork is shown in Fig 37.

The circuit board was etched and assembled into a copper clad and solder housing with SMA connectors for the RF interfaces and feed through capacitors for the 12V transmit and receive biases. DC block capacitors are 2pF or so and decoupling capacitors are $0.1\mu\text{F}$. It is also advisable to add 2pF decoupling capacitors as well.

Photos of the finished transverter are shown in the remaining figures (Figs 38 - 40).

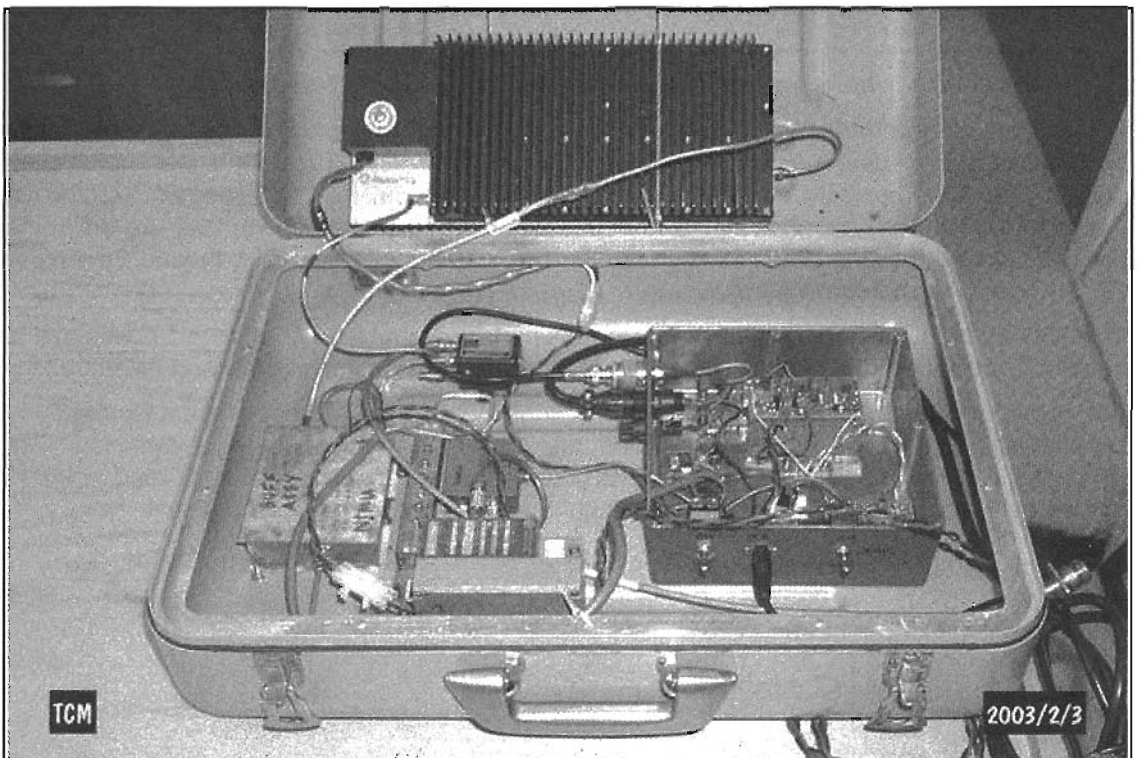

Fig 38: The assembled 5GHz transverter. The PA is at the top, the RF blocks are on the left, and the IF switching and control unit is at the right.

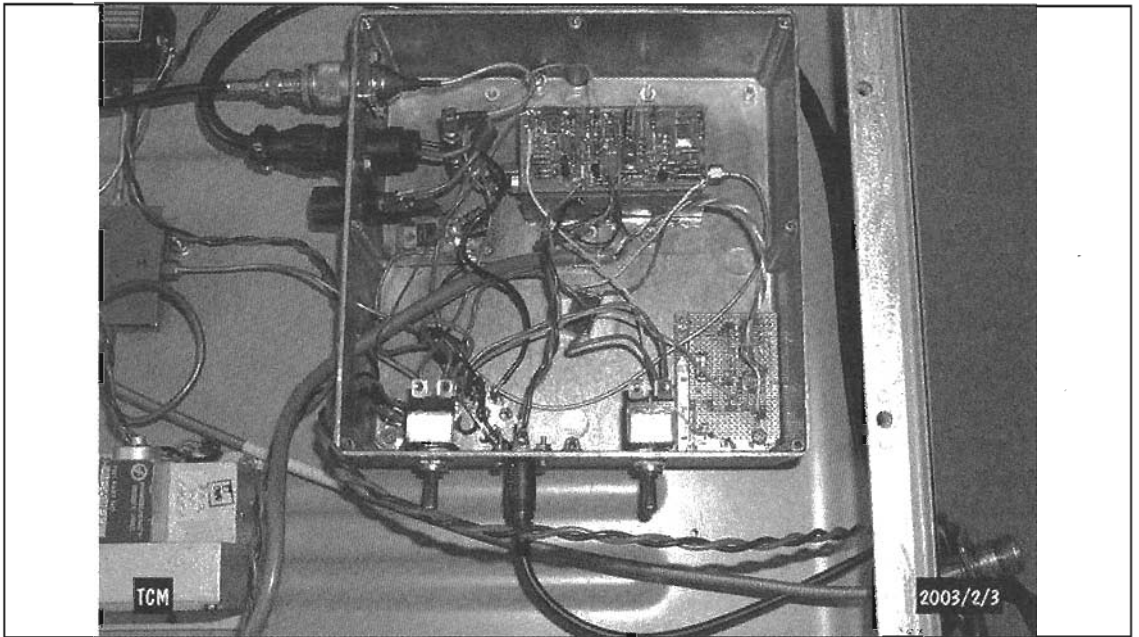

Fig 39: The IF switching and control unit. The relay sequencer is mounted on top of the PIN switched IF attenuator near the top of the photo. The -20VDC regulator is to the left of the box.

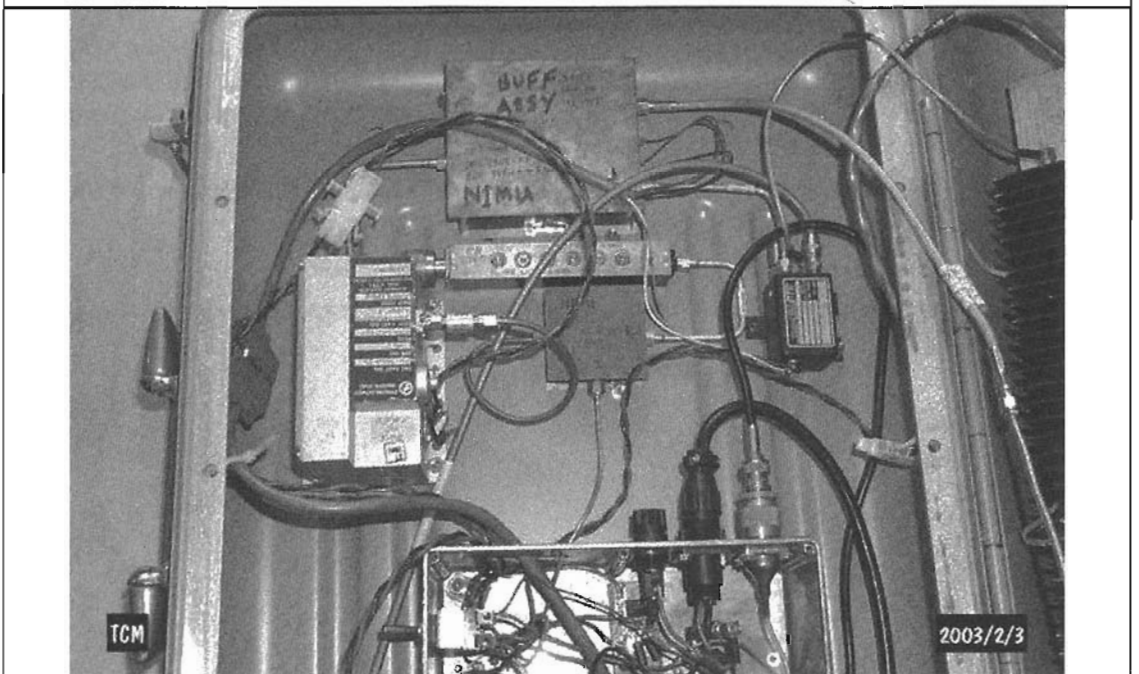

Fig 40: The RF portion of the 5GHz transverter. The buffer assembly is at the top, with the LO, Filter, Mixer and T/R relay below.

Microwave Projects

This transverter has been in operation for microwave rover use during contests with excellent results for about five years. The only maintenance needed was to readjust the Local Oscillator after the crystal had burned in.

References

- [1] Gianfranco Sabbadini, IS2G, No.Tune Transverter for 5.7GHz, DUBUS 2/99
- [2] Chris Bowick, WB4UHY, RF Circuit Design, 1982, Newnes / Sams,
- [3] Carl G Lodström, SM6MOM & KQ6AX, The Noble art of De-Coupling, VHF Communications 2/01
- [4] For further conversion and materials availability information contact Chuck Houghton, WB6IGP (clhough@pacbell.net) or Kerry Banke N6IZW (kbanke@qualcomm.com) of the San Diego Microwave Group.
- [5] Additional conversion information articles and sources:
C. Houghton, WB6IGP & Kerry Banke, N6IZW, "Microwave GAAS FET Amps for Modification to 10 GHz", NTS FEEDPOINT Newsletter, December, 1993.
Bruce Wood, N2LIV, "UP, UP & Away to 10 GHz Semi-Commercial Style", Proceedings of the 20th Eastern VHF/UHF Conference, August, 1994, pg 133
10GHz Qualcomm Modification Notes by Dale Clement, AF1T
- [6] Ken Shofield, W1RIL, "Suggestions for Modifications of Qualcomm LNA Board for 10 GHz", Proceedings of the 21st Eastern VHF/UHF Conference, August, 1995, pg 63 and "Modification Update of Omitrack PA Board for 10 GHz". Pg 65. Also at [http://www.uhavax.hartford.edu/disk\\$userdata/faculty/newsvhf/www/w1ril.html](http://www.uhavax.hartford.edu/disk$userdata/faculty/newsvhf/www/w1ril.html).
- [7] Raven, Greg "How to use PIN diodes in a 2m IF switch", The ARRL UHF/Microwave Projects Manual. ARRL, 1994
- [8] Lau, Zack "A 3456MHz transverter", QEX, ARRL, September 1996
- [9] Troetschel, Bill "UHF/Microwave mixers", The ARRL UHF/Microwave experimenter's manual, ARRL, 1990

Power Amplifiers

In this chapter :

- GH *Quad* linear amplifier for 23cm
- A 10 watt power amplifier for the 13cm band using GaAs technology
- A 13cm power amplifier using a GaAs MMIC
- Amplifier for 47GHz using chip technology

Most transverters only generate low power outputs. It is therefore necessary to have a power amplifier to boost the signal. There are more and more semiconductors and semiconductor modules available to do the job but good designs and constructional techniques are needed to ensure that they produce the required power output and do not destroy themselves. The designs in this chapter show some of the options available.

GH *Quad* linear amplifier for 23cm, Grant Hodgson, G8UBN

Introduction

The GH *Quad* is a high performance solid-state amplifier using 4 Mitsubishi [1] M57762 Power Amplifier modules to deliver up to 72W in the frequency range 1.24 - 1.3 GHz. The amplifier is available as a full kit or mini-kit from GH Engineering [2]. The PA modules require no tuning, being internally matched at the input and output to 50Ω. The modules are biased from a regulated 9V supply. These features make the modules very easy to use, but the downside is that they are very inefficient, typically achieving around 30% efficiency. Therefore, for an output power of 72W, a total DC input power of around 240W is required, of which 168W is dissipated as heat.

It is imperative that the PA modules are not allowed to overheat, and for this reason a large heatsink is used with a thermal resistance of approximately 0.3°C/W. This measures 300 x 250 x 48mm, and weighs 3 kg. The heatsink is a comb section aluminium extrusion that has been black anodised for extra thermal performance. The PCB and PA modules are mounted to the flat surface of the heatsink.

The mechanical construction of the *Quad* is critical for good results and reliability. The *Quad* mini-kit is not supplied with a case, as many constructors are able to supply their own. The first job therefore is to plan the overall mechanical layout. Whilst it would be possible to use the *Quad* without a case, using studs or screws to support the heatsink, this is not recommended for a number of reasons.

Microwave Projects

Specification

Frequency Range	1240 1300MHz (may be operated above 1300MHz with some loss of output power)
Output Power	72 Watts typical (4W input @1260MHz, 13.8V DC supply voltage)
Input Power	4W maximum
Input VSWR	<2:1
Output VSWR	<2:1
Power requirements	12.5 - 13.8V DC @ 23 A
RF Connectors	N-type sockets
Size	305mm x 280mm x 185mm
Weight	3.5kg

Circuit Description

RF

The RF input signal is applied to a Wilkinson splitter that divides the signal into two in-phase components, each 3dB lower than the input signal. The splitter consists of two quarter wavelength transmission lines of 71Ω impedance. The outputs of the splitter are connected by two resistors in parallel which give a value of approximately 100Ω . Under normal operation, the voltages at the ends of the resistors are equal and in phase, and therefore no current flows through the resistors. In the event of an imbalance, for example due to a module failure, some of the input power will be dissipated in the resistors, therefore these resistors have to have sufficient power handling capability to be able to cope with a fault condition.

Considering one of the two signal paths: the signal then passes through a 90° hybrid coupler, which splits the signal into two equal amplitude components, with a relative offset of 90° . Each of the two outputs from the coupler is 3dB lower than the output signals from the Wilkinson splitter. Under normal operation, there is no power dissipated across the 47Ω resistor. In the case of an imbalance, some of the power applied to the input of the coupler will be dissipated in the termination resistor. The impedance mismatch between the 47Ω resistor and the 50Ω impedance of the coupler is very small and is of no importance.

Both the Wilkinson splitter and the quadrature couplers exhibit a high degree of isolation, such that the output impedances are very close to 50Ω even if the other port has a severe mismatch.

The signals are now 6dB lower than the input signal, and the outer pair have a 90° lag relative to the inner pair. The signals are fed to the inputs of the Power Amplifier modules that have a small signal gain of around 17-18dB. The outputs of the modules are phase corrected, such that the inner signals have an extra 90° phase shift added to bring them all back in phase. This is

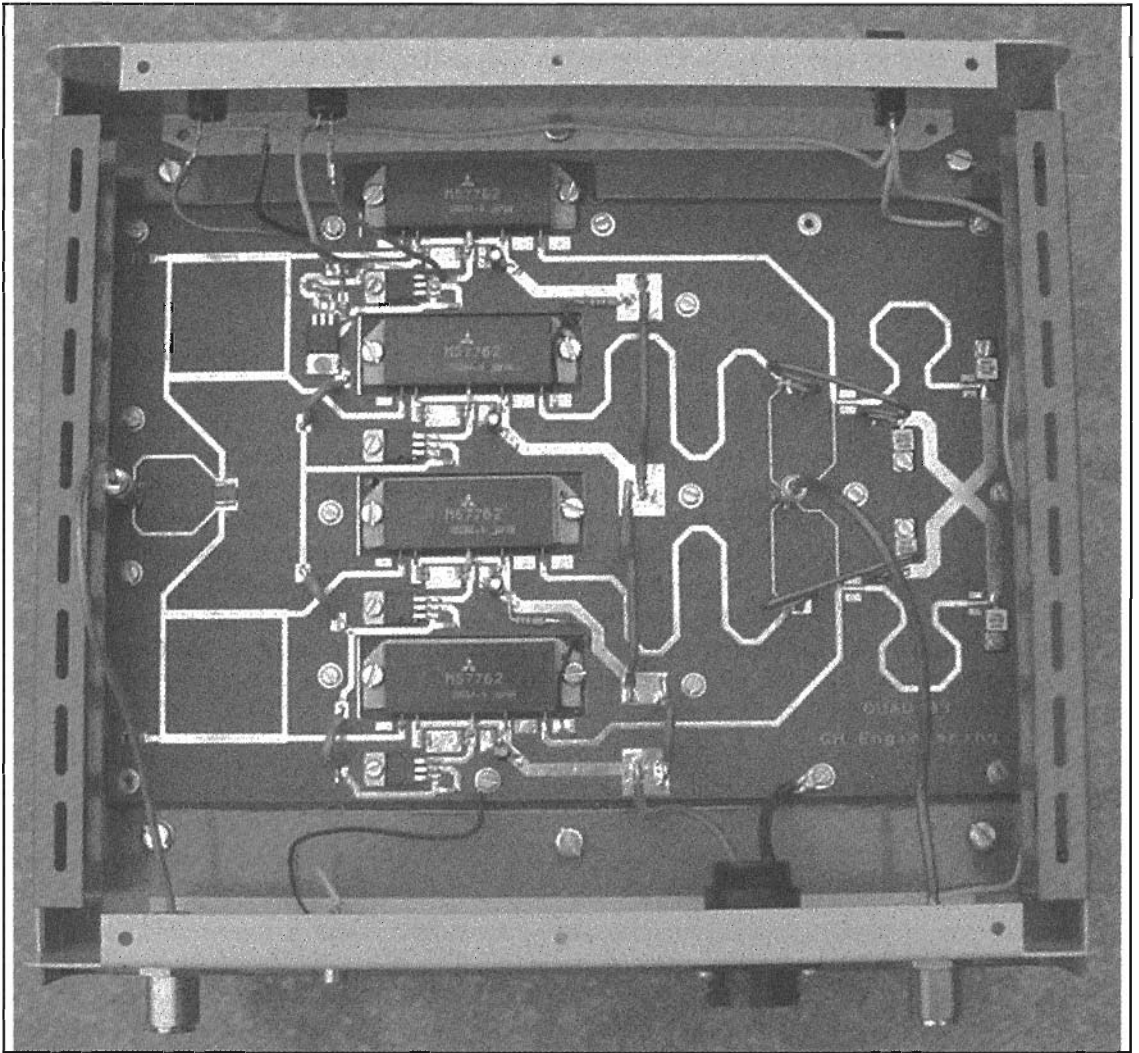

Fig 1: Picture of the GH Quad amplifier mounted in it's case.

achieved with the correct length of microstrip transmission line. The signals are then fed to a 4-way Gysel combiner [3]. This combiner is actually a derivative of the N-way Wilkinson combiner, and is a single, 4-way combiner. The insertion loss for this combiner is less than for the more usual arrangement of cascading 2-way combiners. Note that losses at the amplifier input are not considered to be a problem, as there is sufficient gain to overcome these losses. However, any losses at the output cannot be recovered and therefore a lower-loss, albeit slightly more complex combining network has been designed, along with the use of low-loss PTFE-based PCB material.

The Gysel combiner consists of 4 quarter-wave transmission lines, each of 100Ω impedance. Therefore the 50Ω impedance of the output signals is transformed to 200Ω , which gives an output of 50Ω when all four are connected together in parallel. The isolating network is

Microwave Projects

somewhat more complex than for the input splitters. 50Ω transmission lines, $3/4$ wavelength long are connected to each of the junctions of the 50Ω and 100Ω lines. The end of these lines are terminated with a 50Ω high-power termination resistor. This resistor is also connected to another transmission line of 25Ω impedance and $1/4$ wavelength long. These four 25Ω lines are connected together at a star point. At this point, there is a 'virtual ground', in that no current flows across the junction, but the impedance is actually very high and approaches an open circuit. The impedance at the termination resistor is very low (approaching a short circuit) and no power flows into the resistor. Therefore, the impedance looking into the end of the $3/4$ wavelength line is very high. Consequently, the $3/4$ wavelength line places no load on the output, and no current flows into the isolating network.

In the event of an imbalance, such as that due to a module failure, the situation changes. Some of the output power from the remaining three modules will be dissipated in the terminating resistors, although most will still flow to the output connection. However, each module will still have an impedance of very close to 50Ω presented to it, and so the effect of failure or instability of one module will not be seen by the other modules. Note that the load resistors do not dissipate this power evenly. If, for example, module 1 failed, then approximately 18% of the power from the three remaining modules would be dissipated in the termination resistor associated with module 1, and approximately 5% of the power would be dissipated in each of the other 3 resistors. This power split is irrespective of the nature of the failure; i.e. regardless of whether the module fails open circuit, short circuit or something in between. The Gysel coupler has a bandwidth and isolation similar to that of a Wilkinson splitter, and can cope with any number of module failures.

Note that the input and output combiners have been designed to cope with a worst-case scenario; i.e. the failure of one or more PA modules. However, in practice, the M57762 modules are very reliable, and as long as the input power to each module does not exceed 1W, the DC supply voltage is kept at 13.8V maximum and the modules are not allowed to overheat, they will give many years of trouble-free service.

This feature can be used for diagnostic purposes - if the output power is somewhat lower than it should be, then the voltage across each of the terminating resistors can be measured with a high impedance probe or an RF millivoltmeter. One resistor will have significantly more voltage across it than the other 3, and the fault will lie in the corresponding module. As an alternative to an RF millivoltmeter, each of the terminations can be removed in turn, and replaced with a length of thin coax cable, which is connected to a power meter.

Note that the 'classic' Gysel coupler uses $1/4$ wave line lengths throughout, but this is difficult to implement on the PCB, and so $3/4$ wave sections were chosen. The outer two $3/4$ wavelength lines are printed on the PCB as microstrip transmission lines. The topology of a Gysel coupler is such that is effectively a 3-dimensional structure, and cannot be fully implemented on a 2-layer PCB. The $3/4$ wavelength line for the inner modules have to cross the outer lines, and for this reason are constructed from 0.086" semi-rigid cable.

DC and switching

The DC supply (Vcc) to the PCB is connected via a fuse. This is then applied to the Vcc1 and

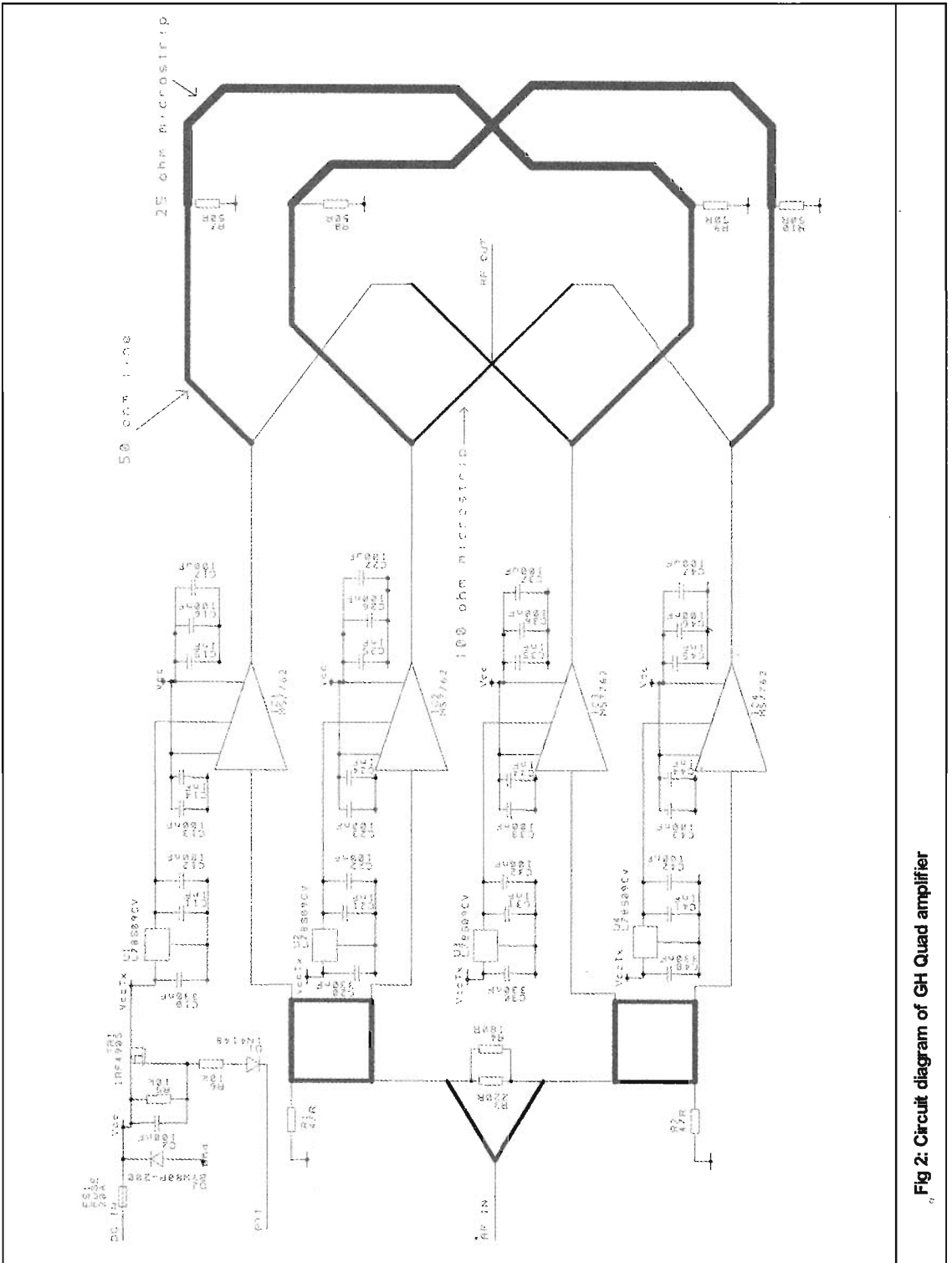

Fig 2: Circuit diagram of GH Quad amplifier

Microwave Projects

Vcc2 pins of the modules. Note that in the Rx/standby mode, the modules will conduct only a very small amount of leakage current.

TR1 is a P-channel MOSFET switch. In the Rx/standby mode, the PTT signal is floating, and R5 ensures that there is no voltage between the drain and source, which keeps the FET switched off. When the PTT line is taken low, the combination of R5 and R6 form a potential divider that takes the gate voltage to approximately half of the supply voltage. This causes the FET to turn on, and the supply voltage appears at the input of the voltage regulators. The regulators provide a stable 9V that is required to bias the modules. C2 de-couples the gate of the FET to prevent accidental switching due to stray RF fields or glitches.

De-coupling is provided on each of the module pins. Note that only relatively low-frequency de-coupling is provided - no attempt is made to de-couple the pins at the RF frequency, as this is done internally within the modules. DC blocking of the input and output signals is performed internally within the M57762 modules.

Reverse Polarity Protection

A 20A quick-blow fuse and a fuseholder are supplied with the mini-kit. This fuse should be connected in series with the positive supply to the amplifier inside the case. D2 acts as a reverse-polarity protection diode, such that if the supply is accidentally reversed, the diode will conduct and blow the fuse. Under these conditions, the reverse voltage will not exceed approximately -0.8V which should be a safe condition.

Operating the amplifier

An input power of 1.5W will give an output power of approximately 65W with a DC power supply of 13.8V. The DC current drawn will be approximately 15-18A. Increasing the drive level above 1.5W will increase both the output power and the DC current, but the amplifier will no longer be linear i.e. a 1dB increase in input will give less than 1dB increase in output. The DC current drawn is approximately proportional to the input power, so even when the amplifier is close to saturation, the DC current will still increase as the input power is increased. The consequence of this is that the efficiency decreases, and the amount of heat generated increases. Therefore, it is necessary to ensure that the modules do not overheat, and the use of one or two small axial fans on the heatsink is recommended if the amplifier is being driven at power levels of greater than 2W, especially for continuous (FM) use.

Note that the input power should never exceed 5W under any conditions. If the amplifier is being driven from a source that is capable of delivering more power than this, e.g. a multi-mode Transceiver such as the FT736 or the TS790, then it is recommended that an attenuator is used at the input to the amplifier. Although these transceivers have adjustable power controls, there is a possibility that the drive control could accidentally be set too high. The M57762 modules are very susceptible to excess drive levels, and could be damaged or destroyed if too much input power is applied. A suitable attenuator can easily be made from a length of thin coaxial cable;

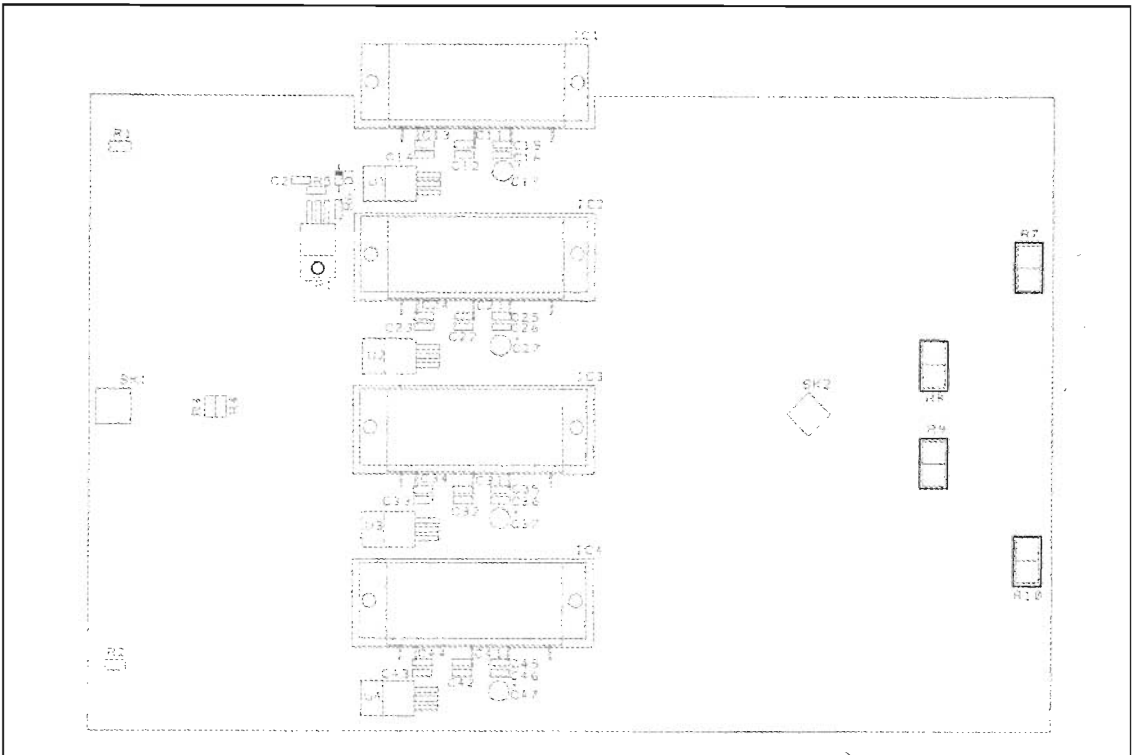

Fig 3: Component layout of the GH Quad amplifier.

for example 3.5m of RG178 cable has a loss of 5dB at 1.3GHz, which allows the driving transceiver to be used at full power (10W) without damaging the amplifier.

Heat Dissipation

The heatsink has been designed to allow the amplifier to be used continuously for SSB or CW operation. Under these conditions, the heatsink will reach a steady-state temperature of around 60°C after approximately 45 minutes of operation with an ambient temperature of 20°C. This is a safe condition for the PA modules. Note that at 60°C, the heatsink will be very hot to the touch, care must be taken to ensure that the operator does not suffer a mild burn from the heatsink.

For FM/ATV use, it is recommended that two axial fans are used to assist cooling of the PA modules

Fault finding

There is very little to go wrong with this amplifier, and no tuning is required. With an input power of 3W and a supply voltage of 13.8V DC, the output power will be approximately 60-80W

Microwave Projects

depending on which part of the band is being used. For SSB use, the input power should not exceed 3W PEP, as this will drive the amplifier into its non-linear region. It is recommended that the input power does not exceed 4W.

If the output power is lower than expected, then the following procedure should be followed:

- Ensure that the output power is being measured on a meter that has sufficient accuracy at 1.3GHz - don't blame the amplifier if the power meter is at fault!
- Visually check all the soldered joints.
- Check that the DC levels are correct on pins 2, 3 and 4 of the PA modules.
- Check that the input attenuator has been fitted correctly.
- Measure the DC supply current - if this is low, then the problem lies with the input. If the current is as expected, the problem is probably in the output section.

PTT operation

The GH *Quad* is provided with a PTT facility which may or may not be required depending on how the rest of the system is to be used. The PTT facility is provided in order to disable the amplifier during receive periods. This has two main advantages:

- If an antenna changeover relay is being used, a high SWR will be presented to the amplifier on receive periods, which is highly undesirable. The amplifier should not be on in this state.
- The amplifier dissipates DC power when no input signal is applied due to the bias current of the PA module. It is advantageous to keep the PA module cool whenever possible.

PTT stands for Press To Talk. It is a term that is used in all SSB and FM speech transmitters and refers to the operator pressing a switch in order to change a transceiver system from receive to transmit for half-duplex operation. The switch is usually on the side of a handheld microphone, although operators using headsets often use foot switches to allow both hands to be free for logging and tuning.

If using a self-contained SSB/FM transceiver, the PTT line will be a direct connection to the transceiver, either via the microphone connection or via a separate PTT input connector on the rear panel. If the transceiver is being used with an external amplifier, then the amplifier needs an external PTT input, such that the amplifier is enabled only during transmit periods. This PTT signal can either be taken from the microphone/PTT switch, or alternatively from a PTT out connection at the rear of the transceiver. If a Transmit/receiver sequencer is being used (see separate note on sequencers below), then the amplifier's PTT input will be taken from an output from the sequencer. This ensures that the system is flexible enough to allow multiple amplifiers to be cascaded, which is often the case at VHF and UHF.

For ATV use, the situation is not so straightforward, for a number of reasons:

- Some ATV operators use a full duplex system.

- Some ATV systems use a microphone with no PTT facility.
- The vast majority of ATV transmitters have no provision for a PTT output.
- Unlike SSB systems, there is no "standard" for the polarity of a PTT line - some systems use ground on transmit, some use +12V on transmit.

If a half-duplex system is used, then the PTT facility should also be used. It would be possible to connect the PTT line to be permanently on, so the amplifier is enabled whenever power is applied. However, this has the disadvantage that the full DC current of 23A will have to be switched at power on. Using the PTT line, the main DC power can be left switched on and the PTT line used to enable the amplifier only during transmit periods.

N.B. If an input signal is applied with the PTT off, then the amplifier may be driven into class C operation. If this occurs, the amplifier will produce a considerable amount of output power, even though the PTT is not enabled. This is a highly undesirable state, and care should be taken to ensure that no drive signal is applied unless the PTT is enabled.

PTT Line polarity

The PTT line polarity is Ground on transmit. D1 acts to prevent high voltages reaching the rest of the amplifier if other amplifiers are connected to a common PTT line. In the receive mode, the PTT line can be either floating or connected to the positive supply.

If +ve on transmit operation is required, an inverter will need to be used. This can be implemented with an NPN transistor and a series resistor in the base. The collector of the transistor is connected to R2 in place of diode D1.

Sequencing

Sequencing only applies to half-duplex systems. Sequencing refers to a system whereby certain delays are introduced into the control lines for the transmitter, power amplifier and masthead pre-amplifier. The purpose of the delays is to ensure protection for the antenna changeover relay and the pre-amp (if used) and transmit power amplifier.

Systems with relatively low levels of transmit power do not generally require sequencing. However, as power levels increase, the risk of damage to the system components also increases.

If sequencing is not employed, then the system changes over from Tx to Rx and vice versa at the same time. The problems associated with this are due to the fact that any antenna changeover relay needs a finite time for the contacts to move from one position to the other. This occurs on both states - Transmit to Receive and Receive to Transmit. There are thus two separate cases:

Microwave Projects

- **Transmit to Receive.** As well as the relay needing time to change over, the Tx carrier needs a finite amount of time to decay. This decay time will depend on the type of transmitter, amplifier and power supply being used. If the antenna changeover relay starts to change over at the same time as the Tx PTT line is removed, then there will still be a certain amount of RF power flowing through the relay contacts as the contacts start to open. This will cause arcing of the contacts and could quickly lead to a deterioration in performance of the change-over relay. A sequencer will keep the relay in the Tx position until the RF power has been removed. There is a second problem involving the use of a masthead preamplifier. If no sequencing is employed, then the DC power to the preamplifier will be applied before the change-over relay has completed the switch to receive. Thus the preamplifier may be presented with a very high input SWR, which may cause it to become unstable.
- **Receive to Transmit.** If the transmitter is activated at the same time as the change-over relay starts to switch to transmit, the relay contacts could arc. This is because the transmitter power could be present at the transmit port of the change-over relay, before the contacts have had time to complete the switch to the transmit position. Furthermore, due to the fact that it may take some time for the de-coupling capacitors in the preamplifier to decay, the preamplifier may still be on as the relay changes over and the transmitter is brought up to full power. Under these conditions, the isolation of the change-over relay will be a lot less than in the steady-state. There is then the possibility that a much larger amount of Tx power is presented to the pre-amplifier, whilst it is still on, which could cause the preamplifier to be damaged or even destroyed.

A sequencer will eliminate these conditions, and many designs have been published over the years. At the time of writing, GH Engineering is not able to offer a suitable sequencer, but it is hoped that this situation may change in the future.

A 10 Watt Power Amplifier for the 13cm Band using GaAs Technology, Harold Fleckner, DC8UG

Developed with the help of PUFF CAD Software

The two-stage power amplifier described in The International Microwave Handbook [4] gives an output power of 5 watts in the 13cm band with linear operation (class A) and 23dB amplification.

This article describes a new amplifier in this development range that yields an output power of 10 watts with a linear amplification of 20dB.

The circuit and layout have once again been designed using PUFF CAD software [7], based on the results from the development work on the 5 watt amplifier. As a result of this, a parallel circuit with two 5 watt stages has been used for the final stage of this amplifier unit.

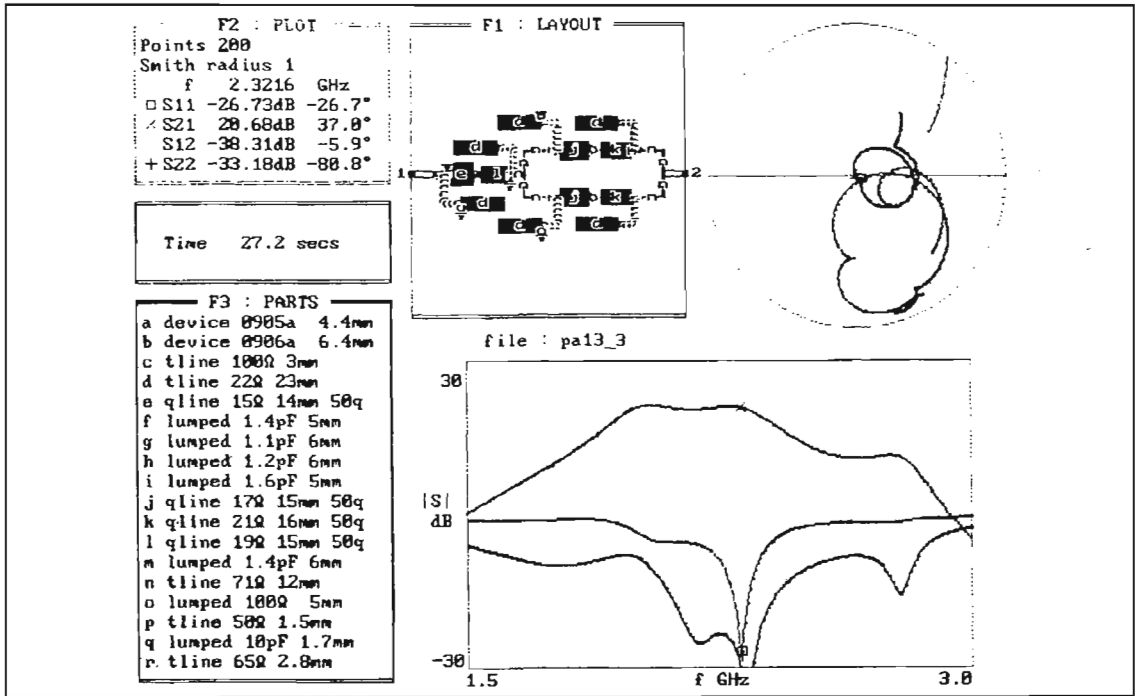

Fig 4: PUFF screen printout showing design of 13cm 10 watt amplifier.

Choice of semiconductor

The transistors used in the amplifier are Mitsubishi GaAsFETs from the 0900 range. The 0905 type is used in the driver stage, with two type 0906's in the parallel output stage.

The following performance data were the targets aimed for in the development work:

- Amplification: > 20dB at $K > 1$
- Output power: Minimum 10w at maximum 1dB compression
- Band width: 100MHz
- $Z_{in} = Z_{out}$: = 50Ω with return loss ≥ 20 dB

The arguments in favour of using a parallel output stage consisting of two 5 watt transistors, rather than a single stage with a 10 watt transistors, are higher efficiency and the higher (in total) power loss of the parallel output stage transistors. Also the 0906 GaAsFET has a better cost/performance than the 10 watt 0907 type.

According to the Mitsubishi data sheet, in the given frequency range the 0906 attains an output power of 5.0 watts = 37dBm at $V_{ds} = 10v$, $I_{ds} = 1.1A$, with an amplification of 11dB at 40% efficiency.

In comparison with the 0907 type (40dBm output power / 10dB / 37%), there is a lower power advantage in favour of the two parallel 0906 stages.

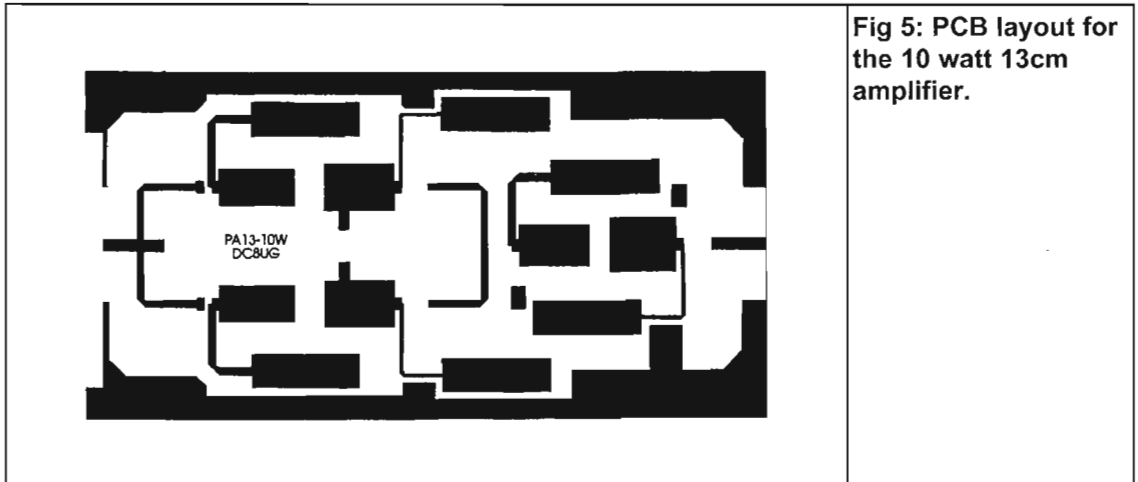

Fig 5: PCB layout for the 10 watt 13cm amplifier.

The 0905 type comfortably supplies the necessary drive power of approximately 1 watt for the parallel stage with an amplification of approximately 10dB. It's typical power is given by Mitsubishi as approximately $34\text{dBm} = 2.5\text{ Watts}$ at $8\text{v} / 0.8\text{A}$.

The S-parameters for the selected transistors required for the circuit development are taken from the Mitsubishi data bank and are valid for the DC voltage conditions referred to above.

In operation, the DC input power exceeds 30 watts, so the heat sink must have generous dimensions, in order to guarantee that the maximum permissible temperature for the transistors, of 175°C is never reached.

Simulation and analysis of amplifier circuit using cad software

The functioning of the PUFF CAD software is described in chapter 5 and [5] [6] [7], so only the results obtained are presented and analysed here. Fig 4 shows the screen print from PUFF showing the layout of the circuit, the associated Smith diagram, the parts list and the scatter parameter curve over the selected frequency range (1.5 - 3.0GHz).

From the calculated scatter parameters, the stability factor, K , of the amplifier circuit can be determined for the operating frequency (2.3216 GHz) [8]. When plotted against frequency, the gain slope obtained (S_{21}) clearly shows the influence of the 71Ω $\lambda/4$ coupler between the two output transistors. This type of coupling assumes a transformation of all individual stages to a 50Ω impedance, and is familiar from aerial engineering. It is relatively loss-free and is particularly effective when each individual stage is transformed before the parallel connection to $Z_{in} = Z_{out} = 50\Omega$. The better this transformation is carried out, the "smoother" the gain-slope against frequency.

The calculated input impedance (S_{11}) is more strongly dependent on the frequency than the output impedance (S_{22}), and here the typical broad band properties of parallel stages show an advantage. The values shown in Fig 4 give the following performance values for the simulated circuit at an operating frequency of 2,320MHz:

Return loss input:	- 26.7dB
Return loss output:	- 33.2dB
Amplification:	+20.7dB
Feedback:	- 38.3dB
K factor at 2,320MHz:	29
Power band width (-3dB):	- 400MHz + 100MHz

Fig 5 shows the layout generated by the CAD software, as a laser printout, for Teflon-based material with a substrate thickness of 0.79mm.

The earth paths are on the top side of the boards and are made using rivets connected through to the underside of the boards.

The parts list in Fig 4 shows the discrete components required, under the description "lumped". These are the capacitors and resistors necessary for the circuit to operate.

Fig 6 shows the circuit diagram for the 10 watt amplifier. Table 1 shows all components required in the parts list.

Amplifier assembly

The amplifier circuit is assembled on a Teflon board ($\epsilon_r = 2.33$) measuring 146mm x 72mm x 0.79mm. It is screwed to a finned aluminium heat sink measuring 147mm x 100mm x 40mm, which acts as a housing and a heat sink for the power transistors and voltage regulator (Fig 8).

The DC voltage supply is mounted on a double-sided epoxy board, measuring 105mm x 20mm x 1.6mm, soldered vertically to the long side of the housing (Fig 8). Fig 7 shows the circuit diagram, Fig 9 the components diagram, and Table 2 the parts list for the power supply. The components are all mounted on the foil side, so that the earth surfaces have to be connected through to the foil side.

Grooves are milled in the heat sink, so that the drain and gate connections of the transistors can be soldered as flat as possible to the board. The grooves are made a little wider than required, to give a greater tolerance when mounting the transistors.

The Teflon board has a cut out of 4.5mm x 17mm and two cut outs of 6.5mm x 22mm, to fit the transistors so that they can be screwed to the heat sink (see Fig 8). Copper foil, measuring 148mm x 73mm x 0.08mm, is fitted between the board and the heat sink. It is later soldered to the tinplate housing which improves the earth connection between the transistors, the board, the housing and the cooling body.

Before the board is installed, the earth surfaces must be through connected using 2mm diameter hollow copper rivets. There should be 3 or 4 rivets per longitudinal side and 1 or 2 rivets per earth link (see Fig 8). The board is fastened to the heat sink by means of 8, M2 screws. The transistors need 2 threaded holes each in the base plate for the source connection.

The tinplate housing measuring 147mm x 72mm x 28mm should have the appropriate holes and recesses cut before assembly. The housing is soldered together and soldered to the

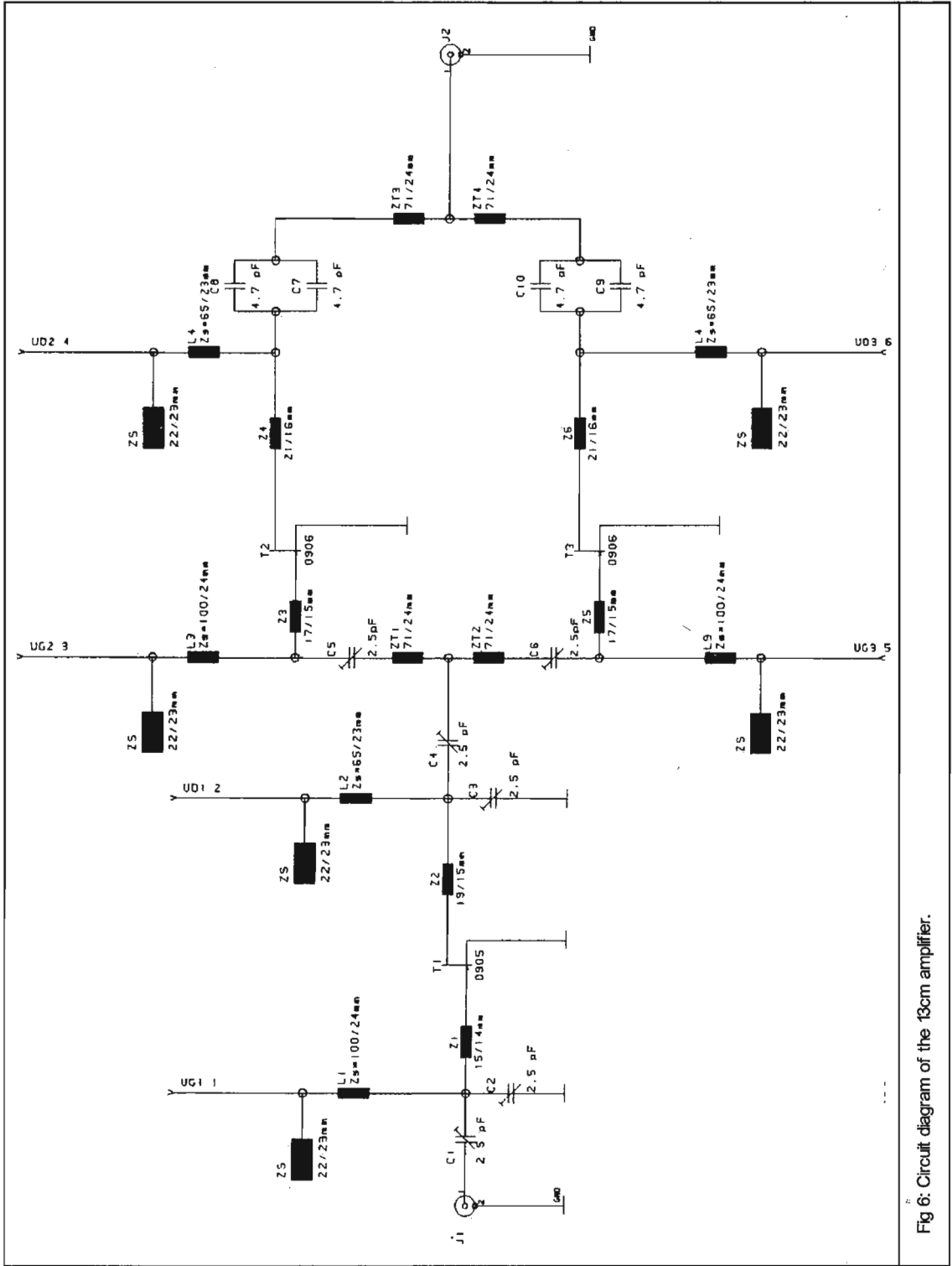

Fig 6: Circuit diagram of the 13cm amplifier.

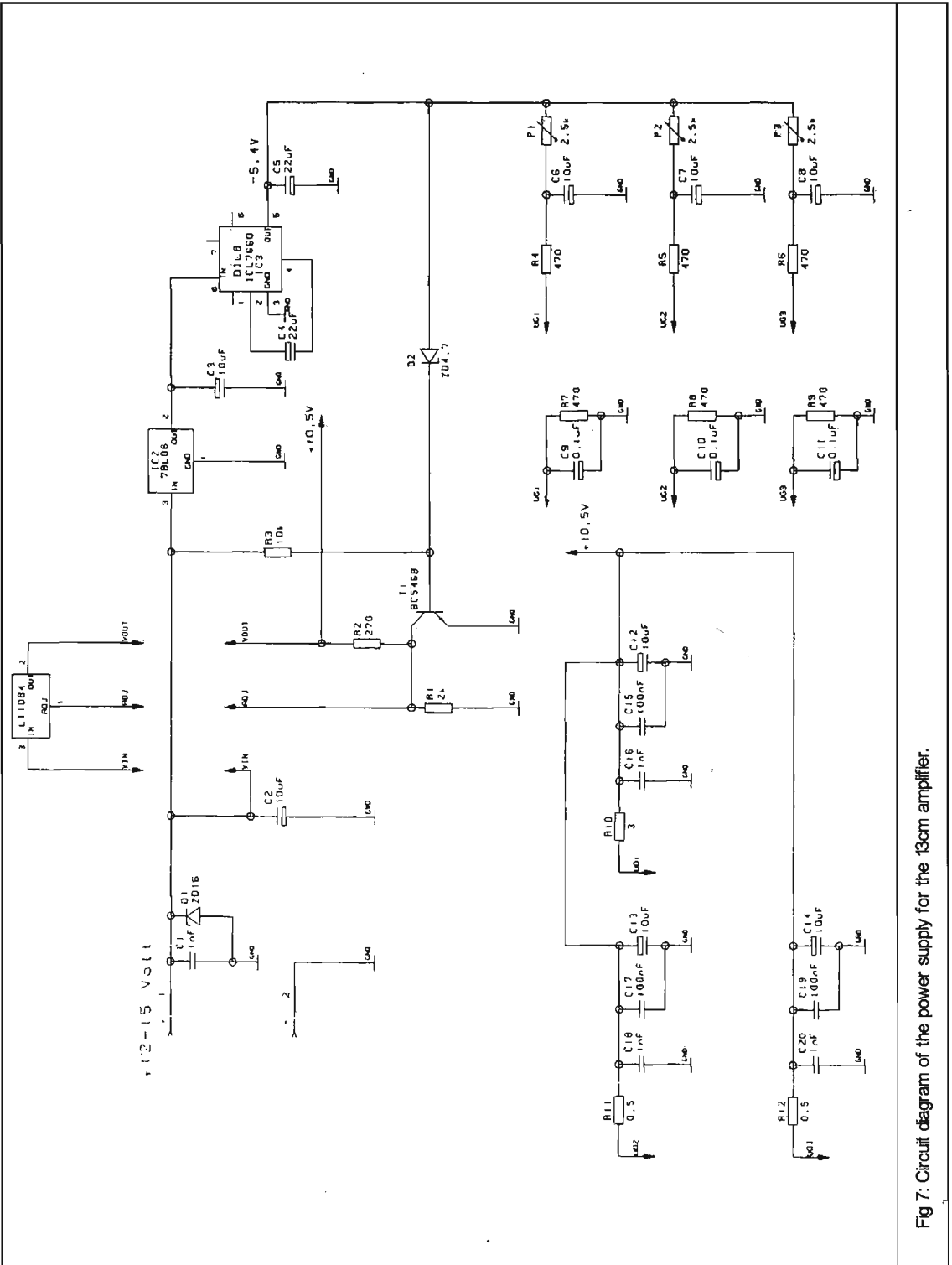

Fig 7: Circuit diagram of the power supply for the 13cm amplifier.

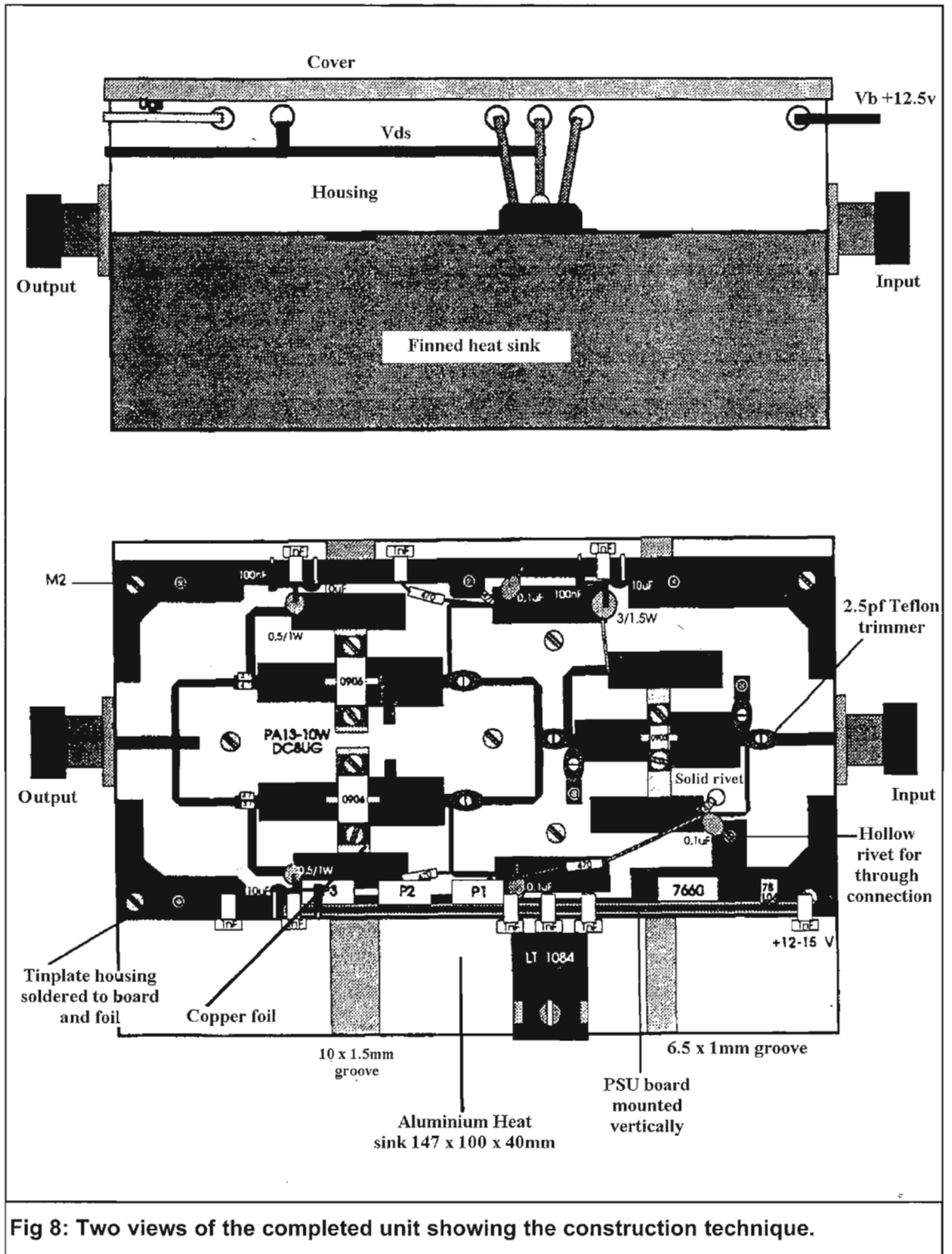

Fig 8: Two views of the completed unit showing the construction technique.

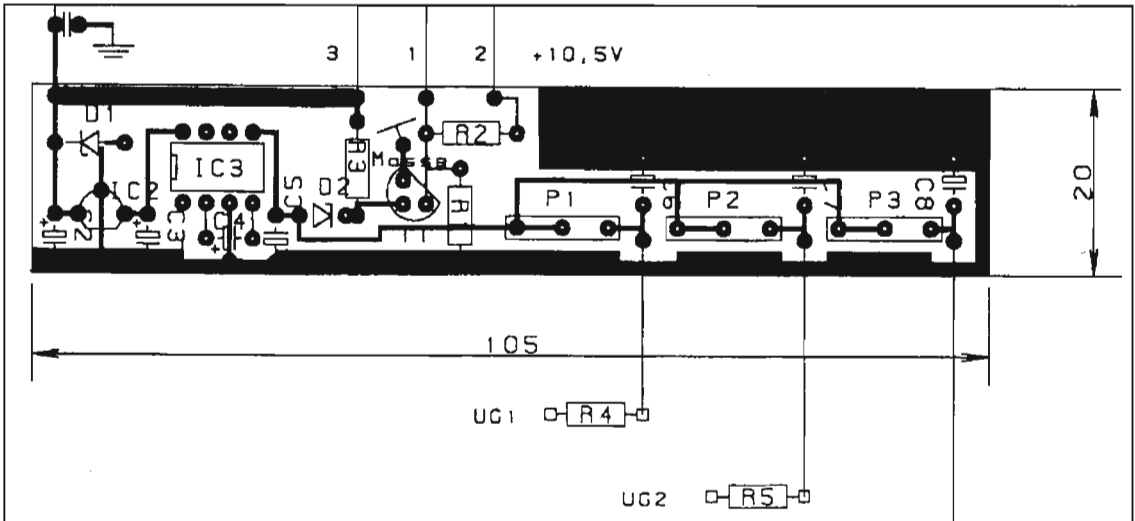

Fig 9: Component layout of the power supply board for the 13cm amplifier.

already fitted board on the long sides. The sockets are soldered and also screwed into the front faces of the heat sink.

The following assembly and test sequence is recommended:

- Assemble and fit the power supply board. The gate resistances (R4, R5) should already be soldered to the power supply for a better assembly!

Tip: To avoid regenerative feedback, the gate power supply connection for the transistor T3 via R6 should not go straight across the board, but must be taken round outside, like the drain power supply (see Fig 8).

- Install and wire up the 8 feedthrough capacitors (1nF) and the blocking capacitors, C9 - C15, C17, C19.
- Insulate, fasten and connect the voltage regulator using feedthrough capacitors.
- Install and connect resistances (R7, R8, R9, R11, R12) on and to high-frequency board.
- Install trimmers (C1 - C6)

Tip: Ceramic trimmers of the Johanson 0.5 - 2.5pF type are more suitable than Teflon trimmers, since they still give stable capacity values, even after repeated calibrations!

- Install chip capacitors (C7 - C10)

Tip: You should definitely use the very low loss ATC 100 porcelain type from Johanson.

- Test the power supply (VG and VD)
- Install GaAsFETs
- Set zero signal currents: 0905 - ID = 0.8A; 0906 - ID = 1.1A

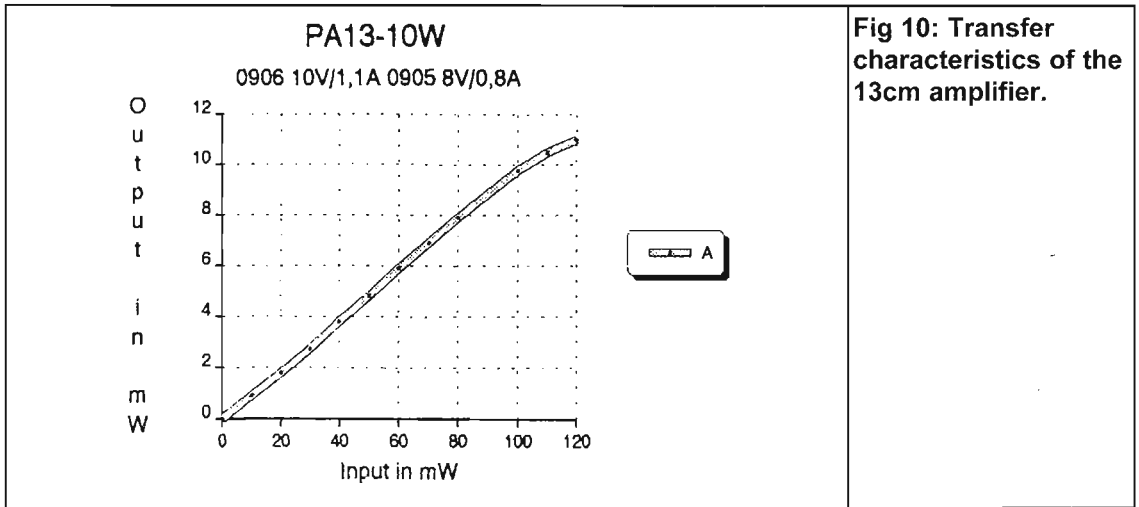

Fig 10: Transfer characteristics of the 13cm amplifier.

Performance

After calibration at 2,320MHz, the prototype attained an output power of 11 watts with a driving power of 120mW. The measurement was carried out using an HP 432B Wattmeter and a 30dB + 10dB attenuator from Narda.

Fig 10 shows the amplifier's transfer characteristic. The compression area begins at an output power of approximately 10.5 watts - i.e. any further increase in power leads to a considerable reduction in the inter-modulation interval and thus to signal distortion in linear mode.

Fig 11 shows the gain curve measured using an HP 8690B sweeper with 8699B at an input power of 50mW and plotted against the frequency.

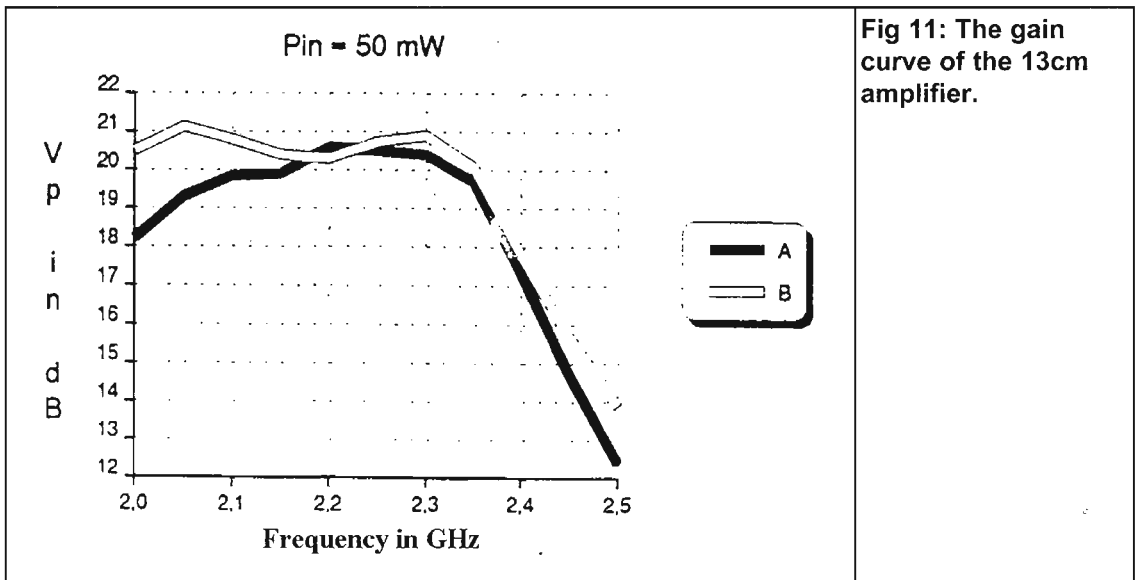

Fig 11: The gain curve of the 13cm amplifier.

Table 1: Parts list for 13cm GaAss Fet amplifier.

C1,C2,C3,C4,C5,C6	Trimmer	2.5pF	Teflon/Ceramic
C7,C8,C9,C10	Capacitor	4.7pF	ATC-Chip 100
J1, J2	Socket	N-type or SMA	
L1,L3,L5	Inductor	100/24mm Stripline	
L2,L4,L6	Inductor	65/23mm Stripline	
T1,	FET	0905	Mitsubishi
T2,T3	FET	0906	Mitsubishi
ZS	Inductor	22/23mm Stripline	
Z1	Inductor	15/14mm Stripline	
Z2	Inductor	19/15mm Stripline	
Z3,Z5	Inductor	17/15mm Stripline	
Z4,Z6	Inductor	21/16mm Stripline	
ZT1-ZT4	Inductor	71/24mm Stripline	

Curve A shows the slope measured for an amplifier tuned to 2,320MHz. Curve B shows the slope in a simulation of S21, as per Fig I. The amplifier consequently has a power band width of over 100MHz. The linear amplification of 20dB attained deviates only slightly from the calculated values.

Table 2: Parts list for 13cm GaAs Fet amplifier power supply.

C1	Capacitor	1nF	Feed-Through
C2,C3,C12,C13,C14	Capacitor	10µF	Tantalum 16V
C4,C4	Capacitor	22µF	Tantalum 10V
C6,C7,C8	Capacitor	10µF	Tantalum 10V
C9,C10,C11	Capacitor	0.1µF	Tantalum 10V
C15,C17,C19	Capacitor	100nF	
C16,C18,C20	Capacitor	1nF	Feed-Through
D1	Diode	ZD16	Zener
D2	Diode	ZD4.7	Zener
IC1	Voltage Regulator	LT1084	Low Drop T0247
IC2	Voltage Regulator	78L06	T092
IC3	DC-DC Converter	ICL7660	DIL8
P1,P2,P3	Potentiometer	2.5kΩ (2kΩ)	Piher/Cermet
R1	Resistor	2kΩ (22KΩ in parallel with 2.2KΩ)	Metal Film
R2	Resistor	270Ω	Metal Film
R3	Resistor	10kΩ	Metal Film
R4,R5,R6	Resistor	470Ω	Metal Film
R7,R8,R9	Resistor	470Ω	SMD
R10	Resistor	3Ω/1.5W	Metal Film (3 x 10Ω)
R11,R12	Resistor	0.5Ω / 1W	Metal Film (2x1Ω)
T1	Transistor	BC546B	NPN T092
5 x 1nF Feed-Through capacitors for PSU from UG3 and LT1084, (see Fig 4)			

A 13cm power amplifier using a GaAs MMIC, Ian Bennett G6TVJ

Having built a simple synthesised 13cm ATV exciter my thoughts turned to what could be used as a power amplifier. The exciter produces about 10mW perhaps enough to drive some sort of MMIC or hybrid amplifier. The problem with 13cm, is that at 2.3GHz and beyond, devices (either discrete transistors or amplifiers) get very expensive. After researching a number of manufacturers and suppliers I eventually came up with an IC amplifier costing about £40 and producing almost a watt, at these frequencies not a bad power to price ratio.

The PM2104 manufactured by Pacific Monolithics is a GaAs MMIC amplifier device intended for ISM applications centred on 2.440GHz, the device is relatively wide band so covers the whole of the 13cm amateur band. The IC has a gain of 24dB and runs on a supply of +5V. It also requires two negative bias supplies similar to other GaAs Fet amplifiers. The 2104 is a surface mount device housed in a SOT8 package and its heat sink is a metalised base, it is very small so is not recommended for newcomers to surface mount construction techniques.

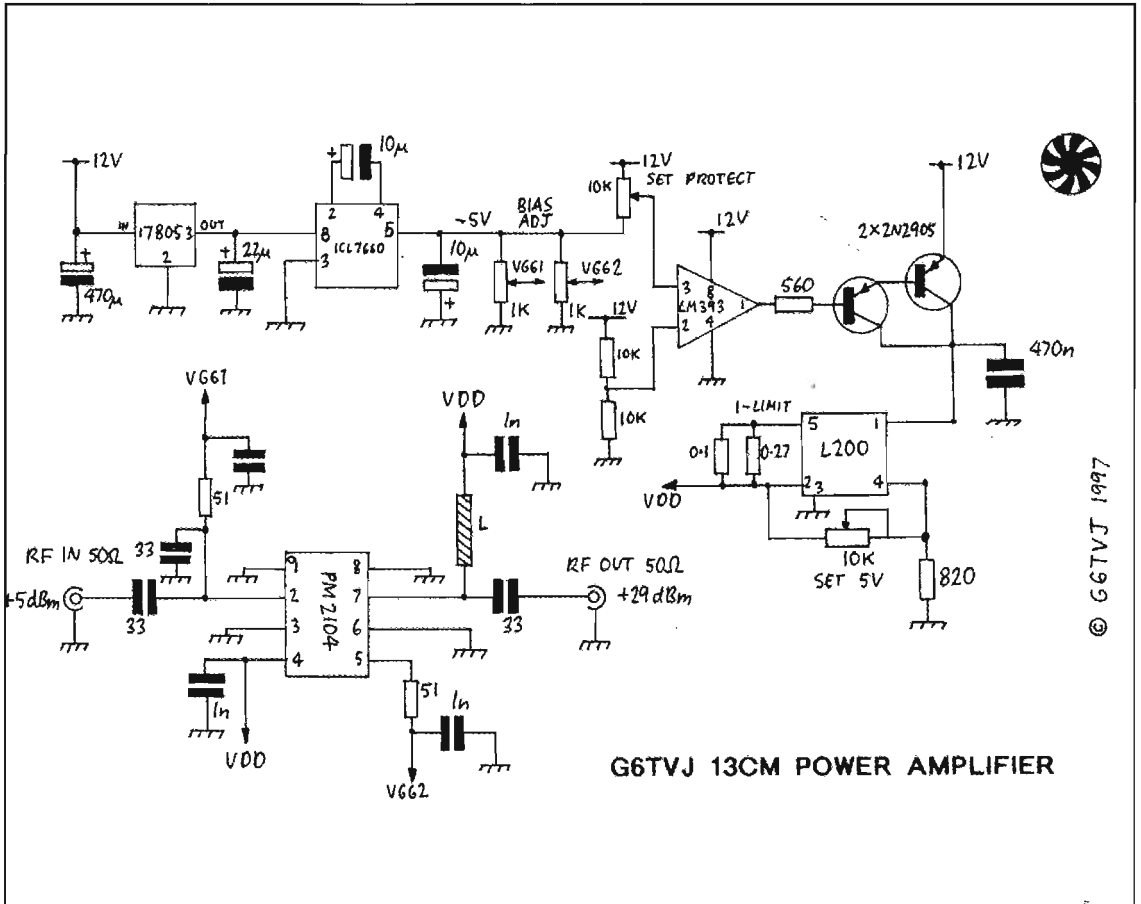

G6TVJ 13CM POWER AMPLIFIER

Fig 12: Circuit diagram of 13cm power amplifier.

Mounting the device on an enclosed PCB and supplying it with negative bias and a positive supply can make a complete amplifier.

All the clever stuff is done inside the PM2104 IC, Fig 12 shows the circuit diagram of the amplifier. The bias supplies and positive supplies are decoupled, some 50Ω matching resistors and a 33pF capacitor are also required. The device is nominally pre-matched to 50Ω but a 33pF matching capacitor is needed at the input pin.

The device is powered on pins 4 and 8 with 5V. Negative bias is supplied to pins 2 and 5. An ICL7660 DC to DC converter chip is used to generate the negative supply in a similar manner to that used in some of the Microwave Committee 3cms units. A simple comparator circuit is used to detect the presence of the bias supplies and then switch on the +5V VDD supply to the IC. If the bias voltage fails the IC may be destroyed so the comparator is needed to protect it. As a second measure the L200 5V regulator incorporates a current limit set to about 600mA. I have not proved the action of this circuit but after the touch and go action of soldering the IC in and the £40 hole in my pocket I thought I would put it in.

Construction

The bias generator, comparator, and regulators can be built on stripboard as convenient, only mild heatsinking is required. A standard fibreglass double sided PCB is etched to the pattern shown (Fig 13), the layout comes from the manufacturer's data sheet. The base of the IC is metalised and must be soldered down to the board to form a heatsink. First tin the underside, solder down the pins and finally solder down the base by applying the iron to each side. The operation of mounting the IC is very tricky so not recommended for people without previous experience of working with surface mount devices. The other components can be added including several via pins that help earth the device. The PCB is then mounted in a tinplate box and fitted with SMA connectors using a technique similar to that used for the RSGB microwave committee 3cm amplifiers.

Alignment

The data sheet suggests that pin 2 should be set to -1.2V and pin 5 set to -1.5V, it is best to start with more negative bias and reduce them carefully while monitoring the supply current and power out. It is worth checking the action of the L200 current limit first with a dummy load. The protection circuit can be set up by adjusting the protect pot until the VDD supply just switches on. This best done before connecting the VDD supply to the 2104. I found that I could get the best efficiency with slightly different values of bias. By comparing the DC power in and RF power out, the bias can be tweaked for minimum power dissipation of the PM2104. The values I ended up with were -1V and -2.2V for pins 2 and 5 respectively. The attainable output power should be up to about 800mW, +29dBm with 5mW of drive. The PM2104 runs warm to the touch in operation.

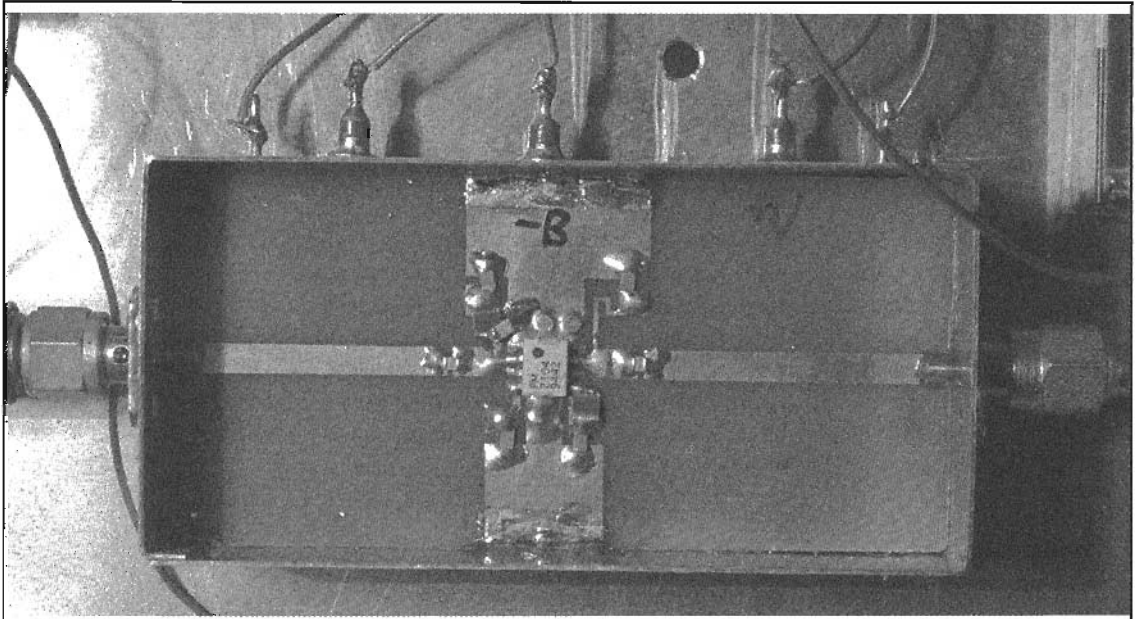

Fig 13: Picture of the 13cm power amplifier.

Components

The PM2104 is available from Richardson Electronics [7]. It is also worth obtaining the Application note on the device No. 2494A [8]. The Tinplate box came from Piper Communications, type 7752. The other surface mount bits came from Mainline including the 50 Ω resistors. It is best to use ATC type capacitors if available.

Conclusion

In the absence of a better solution for attaining medium levels of power at these frequencies the PM2104 does OK. The amplifier has provided good service facilitating P5 pictures over a few miles and some 50 miles on last year's ATV contest. At £40 not a bad mW per £ ratio at these

Amplifier For 47 GHz Using Chip Technology, Sigurd Werner, DL 9MFV

The article below describes a project to construct an amplifier for the 47GHz microwave band. The two stage amplifier uses semiconductor chips from United Monolithic Semiconductors, S.A.S. and gives at least 26dB gain. Anyone actually constructing this power amplifier must have access to bond technology.

Introduction

The non-thermal effects of pulsed high frequencies are being examined as part of certain research projects [11]. Of particular interest are the effects of high frequencies on the activity of protein based bodies (enzymes). Since molecular resonances are to be expected in the range of approximately 42 to 46GHz, the experiments began in this range.

In addition to a generator and measuring equipment for this frequency range, we needed (among other things) a good stable power amplifier. This article shows that the amplifier designed and assembled is also suitable for use on the amateur radio frequency of 47,088MHz. This description could prove a stimulus for people with projects of their own.

Selection of semiconductors

The use of discrete semiconductors in the GHz range referred to is always very expensive for radio amateurs and is combined with considerable design expenditure. An alternative is the use of suitable semiconductor chips, which are glued onto a carrier material, and their connections bonded.

Unfortunately, there are no ready made chips for this frequency range, so some DIY work is called for.

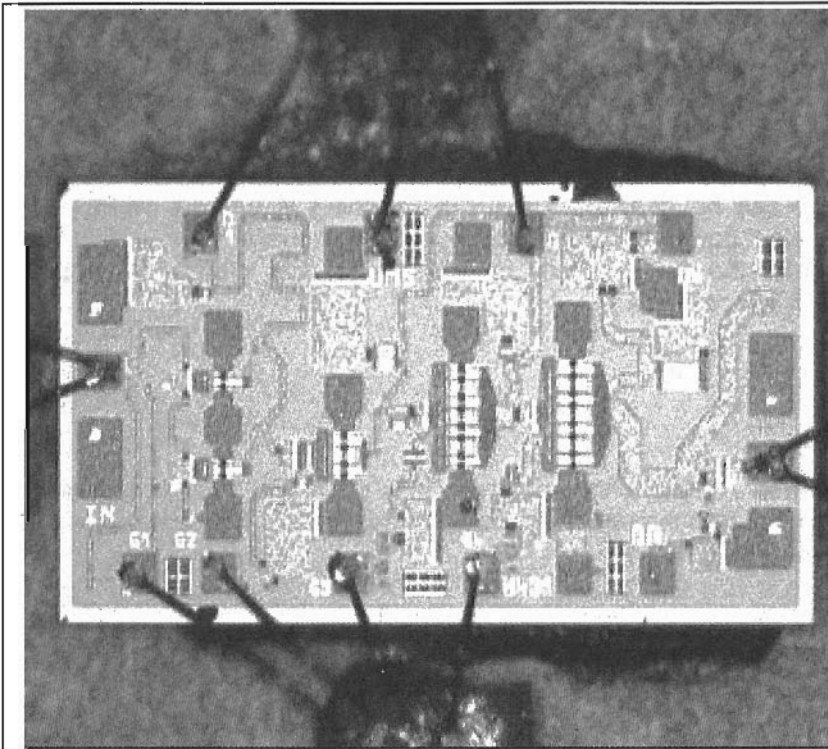

Fig 14: A magnified picture (x120) of the CHA 3093c chip from UMS used in the 47GHz amplifier.

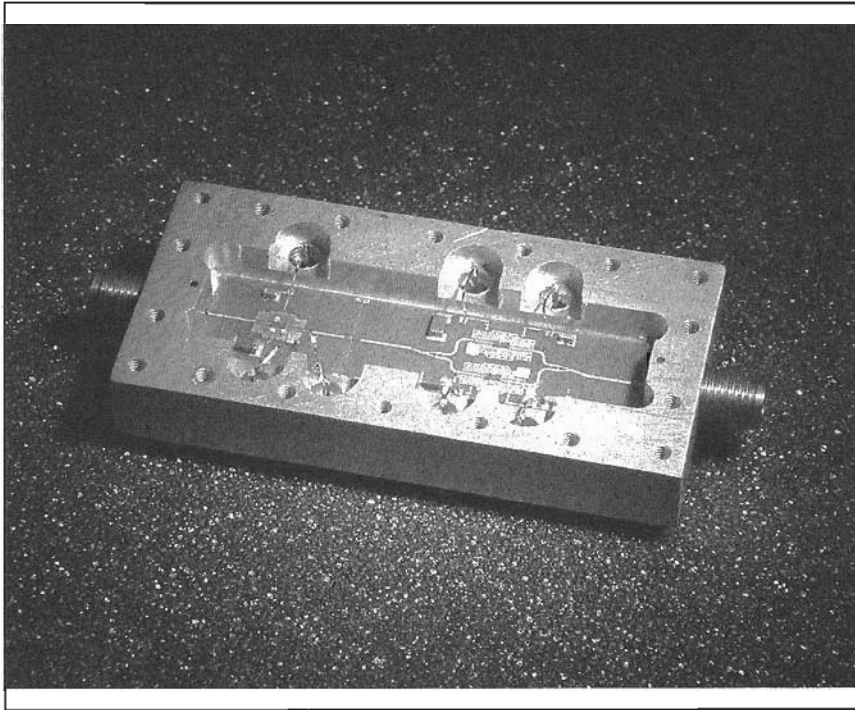

Fig 15: Assembly of two stage 47GHz amplifier in a gold plated milled housing. The Wilkinson dividers can be recognised easily.

After an examination of the data sheets from various chip manufacturers, the CHA3093c from UMS (United Monolithic Semiconductors, S.A.S.) was chosen.

In the data sheet, this chip is specified for frequencies between 20 and 40GHz, but when the S parameters were studied, they were listed for up to 50GHz, the amplification value for 47GHz was found to be at least 17.3dB.

However, this applies only to measurements on the wafer but with a good construction values of approximately 14 to 15dB can be attained. The input matching is 11.1dB, which is an acceptable value. A saturated power of 22dBm, approximately 150mW, is specified (3dB compression). Fig. 14 shows the chips, greatly magnified. The four groups of cascaded semiconductors can be clearly recognised.

Circuit design

The design is relatively simple. A driver chip feeds two chips in parallel through a Wilkinson divider. The power is combined again through a second Wilkinson divider. The same chips (type CHA 3093c) are used for all three devices.

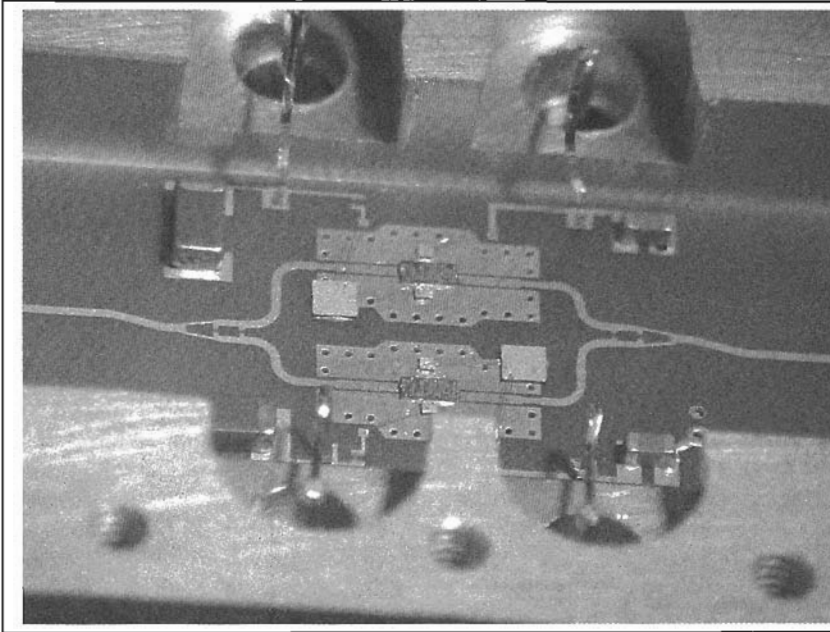

Fig 16: Detail of the 47GHz driver assembly.

Mechanical and electrical construction

The housing for the prototype was milled from brass (60 x 30 x 9 mm.) and gold plated. The depth of the cavity is 4.8mm. K plugs (2.4 mm.) were mounted at the input and output of the amplifier circuit. Fig. 15 illustrates the construction of the amplifier.

The carrier substrate is a thin ceramic plate made from aluminium nitride (AlN, $\epsilon_r = 9.0$) which is only 0.254 mm. thick. The microstrip lines have each been connected to the chip surfaces through a co-planar spacer. Thanks to the good thermal conductivity of the aluminium nitride, the chips can be glued directly onto the substrate.

The power leads for the gate and the drain are decoupled using 100pF capacitors, for longer paths there are also 1nF single layer capacitors and 100nF ceramic capacitors. These are fed through the housing base using soldered in feedthrough capacitors.

The chips were bonded by means of thermo-compression (including ultrasound support), using 17.5 μ m. gold thread. Chips, capacitors and substrate were attached using a single component silver conductive adhesive [9] hardened at 150°C. Figs. 16 and 17 show details of the construction.

The gate bias of the first semiconductor stage on the driver chip was provided separately. Its drive is intended to test the use of the driver chip as a multiplier. A connection to the monitor diode of the chip was dispensed with for the prototype.

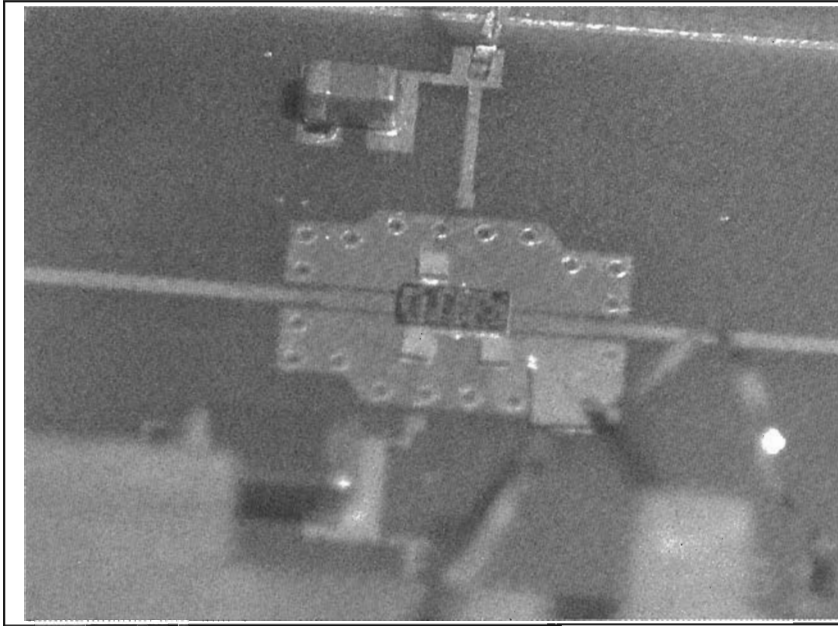

Fig 17: Detail of the 47GHz second stage with parallel wired amplifier chips.

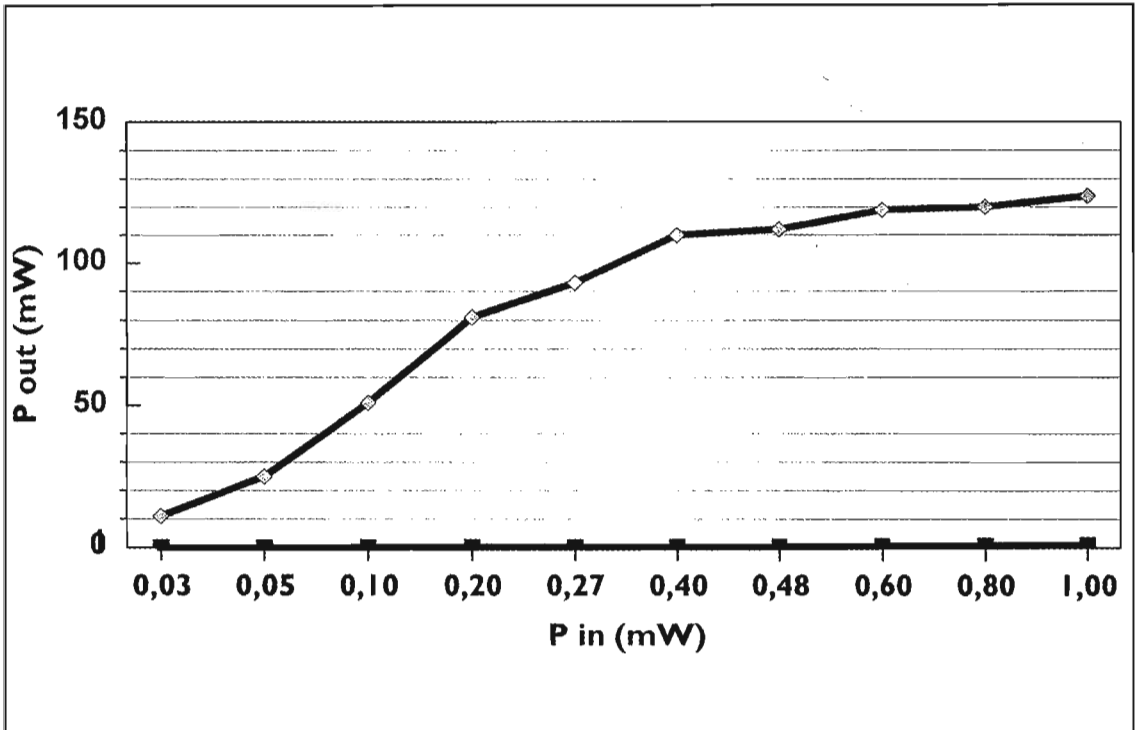

Fig 18: The output of the 47GHz amplifier plotted against the driving power, measured with a CW signal at 47,088MHz.

Results

The drain current per chip (at 3.6V) was set at 360mA. This requires a negative gate voltage of approximately 0.6 - 0.5Volts. A heat sink is necessary for continuous operation, since the power consumption is almost 4W.

The amplifier was initially driven using a CW signal (47088 MHz) of 200 μ W. The power level of approximately 20mW measured at the output which could be raised to 80mW by rough optimisation. In the output area of the chip there was a marked mismatching (the S22 parameter is only 5.8 dB!).

The calculated amplification is approximately 26dB, i.e. 13dB per stage. The -3 dB compression point is at approximately 20.7dBm.

With suitable drive, a saturation power exceeding 120mW can be attained (Fig. 18). This means that the values specified in the data sheet were not attained. This applies, in particular, to the saturation power reached for one chip of only 17.8dBm. This could be because the semiconductors are designed for pulsed mode operation.

The amplifier is particularly sensitive to heat, even with a moderately warm housing, the output drops by 15 to 20%. A generously dimensioned heat sink must therefore be used. To counteract waveguide effects, absorption material should be applied in the input and output areas before the metal cover is fitted.

Outlook and acknowledgements

This article indicates the options for modern chips, and is intended to act as a stimulus for further experiments.

Some other interesting types of chip have recently come onto the market, these are just waiting to be tested. The price of a chip is somewhere around one Euro, depending on the source of supply. At the VHF/UHF Congress in Munich at the beginning of March, Michael Kuhne (DB6 NT) introduced a project for a 47GHz preamplifier. A particularly low noise chip is used, type CHA 2157 from UMS [10].

In conclusion, I would like to thank several helpful people who have supported me in word and deed, namely Konrad Hupler (DJ1EE), Walter Ludwig (DL6SAQ), Mrs. Astrid Habel (Technical University, Munich) and Mr. Wilhelm Hohenester of Rhode & Schwarz, Munich.

References

[1] www.mitsubishichips.com

[2] GH Engineering, The Forge, West End, Sherborne St. John, Hants RG24 9LE, UK Tel +44 (0)1256 889295, web: <http://www.ghengineering.co.uk>

Microwave Projects

- [3] Ulrich Gysel - A new N-way power divider/combiner suitable for high power applications, IEEE MTT-S Symposium Digest 1975
- [4] Fleckner, H.: A Power Amplifier for the 13cm Band using GaAs Technology VHF Communications 3/1994, pp. 130-141
- [5] Bertelsmeier, R.: PUFF-Design Software Dubus-Info, vol. 18 (1989), no. 4, pp. 30 - 33
- [6] Lentz, R.E.: PUFF - a CAD Program for Microwave Stripline Circuits VHF Communications 2/1991, pp. 66-68
- [7] Wedge, S.W., Compton, R. and Rutledge, D
- [8] Unger / Harth: High-Frequency Semi-Conductor Electronics Hirzel-Verlag Stuttgart ISBN 37776 0235 3
- [6] M Kuhne, High-Power GaAs-FET Amplifier for 9cm, Dubus-Info, vol. 20(1991), no.2, pp 7- 16
- [7] Richardson Electronics, <http://www.rell.com>, tel +44 (0)1522 542631
- [8] Data sheet from United Monolithic Semi-conductors, S.A.S.; Ref.: DSCHA30930207, 26/7/ 2000
- [9] Technical Data Sheet, Ablebond 84-1LMI from Ablestik
- [10] Michael Kuhne, DB 6 NT Manuscript for VHF / UHF 2002, 14th Congress, Munich 2002
- [11] Institute for Physiological Chemistry of University of Munich

Test Equipment

In this chapter :

- A sensitive thermal power meter
- A grid dip meter
- A SINAD meter
- A $\div 10$ 5GHz pre divider
- Made to measure directional couplers
- A $\div 10$ 10GHz prescaler using state-of-the-art ICs

The success or failure of a home construction project can depend on the test equipment that is available. Some amateurs have access to lots of sophisticated equipment but most have to use simpler equipment and lots of ingenuity.

This chapter contains some useful test equipment designs. Many of the designs are from fairly old articles but because of this they are simple and easy to build using tried and tested technology.

A Sensitive Thermal Power Meter, Carsten Vieland, DJ4GC

A measuring instrument is to be described that has seven measuring ranges from $100\mu\text{W}$ to 300 mW, and whose upper frequency limit is way up in the X-band! Construction should not be difficult for those readers having adequate mechanical skill, and a magnifying glass, only a few special parts are required which are easily available.

Power measurement problems

For radio amateurs, power measurement is probably one of the most difficult areas in radio frequency measuring technology. The various types of diode voltmeters, see Fig. 1, have three distinct disadvantages:

- The junction capacitance of the test diode (1-4 pF) represents a parallel capacitance to the load resistance. For instance, the amount of the capacitive reactive impedance will be less than the 50Ω load resistor when using a Schottky diode HP 2800 even at 1.6GHz. In conjunction with the unavoidable circuit inductance, this will lead to noticeable resonance effects, which limit this type of power measurement to frequencies up to approximately 1GHz, if a special scale calibration is not used.

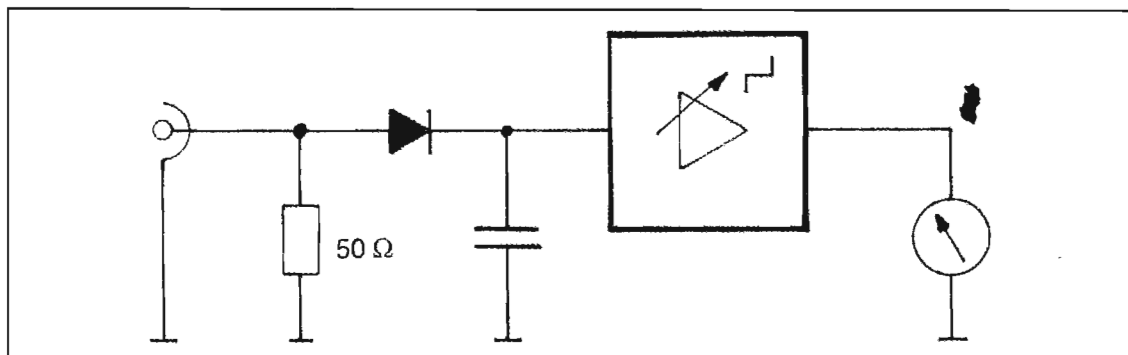

Fig 1: A diode voltmeter as a power meter.

- The non-linearity of the diode characteristic will be noticeable at low AC voltages. This leads to a non-linear scale calibration in spite of subsequent anti-logarithmic amplification. If one is to avoid very extensive compensation, it will be necessary for the scale to be calibrated point by point, for instance by calibrating it against a precision meter.
- The calibration of the diode voltmeter is made in RMS-values. However, the measurements are made with peak voltages. In the case of subsequent measurements on amateur equipment, the required sine wave signal will be superimposed with harmonics, sub-harmonics, conversion products, and unwanted oscillations. When the maximum values of the individual voltages coincide, peak voltages are fed to the diode, which have no relationship to the RMS value. The output power of oscillating stages can be even higher than power consumption from the power line.

The described disadvantages of diode voltmeters can be avoided or at least reduced when using the bolometer principle (see Fig 2), since the load resistance is only to be found in the RF circuit. The heating is a linear function of the RMS value of the RF power, at least at low temperatures. The temperature increase is measured with the aid of NTC thermistor, which will give a linear power scale. Calibration and accuracy measurements can be made with the aid of DC voltages.

Fundamental considerations were made in [1], [2], [3] and [4]. A suitable construction was

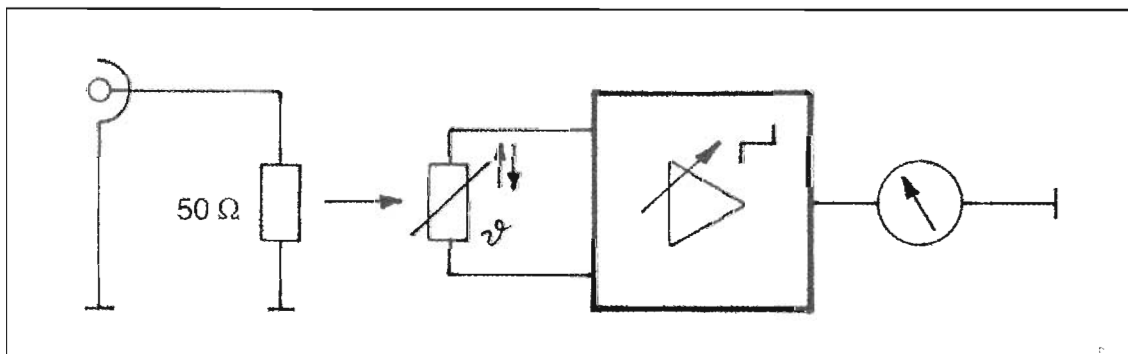

Fig 2: Principle of a thermo-power meter using the bolometer principle.

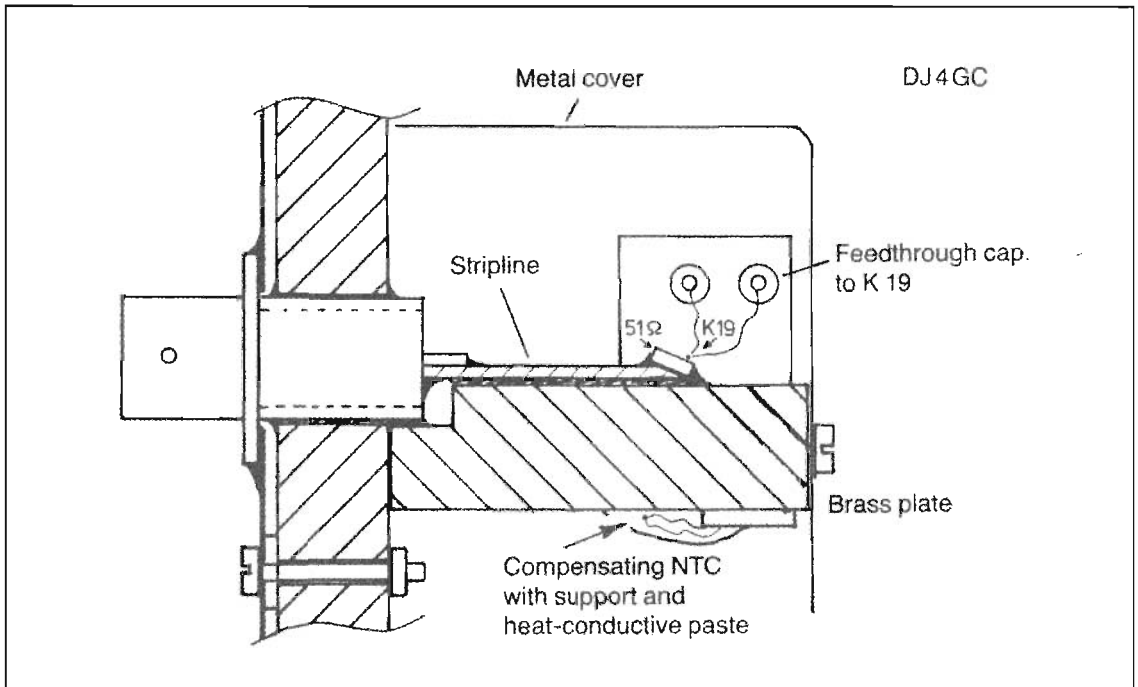

Fig 3: Suitable construction of the bolometer.

described in [1]. Higher sensitivities can be achieved with the aid of thermo-elements using thin-film technology [5].

The meter described has seven measuring ranges from $100\mu\text{W}$ to 300mW (FSD). Its upper frequency limit is in the X-band. One disadvantage is the somewhat long transient time of this method (50% of full scale after 1s), this means that no modulation measurements can be made.

Component selection

The 50Ω load resistor should be as small as possible. A small mass results in a short transient thermal time, as well as a high temperature coefficient (meter sensitivity), and has a positive effect on the upper limit frequency. The smallest, inexpensive, available resistor (51Ω) uses a flat metal glazed conductor and is sometimes designated as micro-miniature resistor (62.5mW). It is in the form of a bead-type microchip resistor that has been dipped in lacquer. After carefully removing the lacquer, one will obtain a ceramic chip whose dimensions are $2.2\text{mm} \times 1.2\text{mm} \times 0.8\text{mm}$.

The temperature probe thermistor should also have a low mass and thus a short transient time. In addition to this, high impedance resistors are preferable, since these exhibit the lowest intrinsic heating as result of the connected test voltage. The Siemens Thernewid-NTC resistor type K19 [6] is very suitable. This component comprises a glass bead of 0.4mm diameter and has virtually invisible connection wires. This component is so sensitive that it will react to the

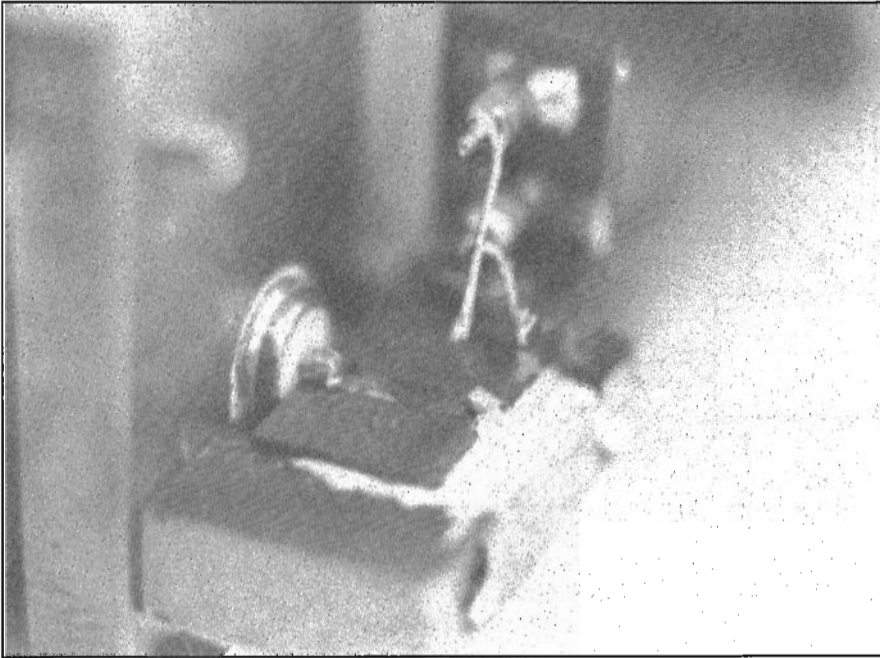

Fig 4: RF circuit with bolometer and heat sink.

radiation heat of one's hand without delay, even at a spacing of 1 meter. Unfortunately, this thermistor, which can also be supplied in pairs, is expensive, but it is also available from several other manufacturers.

Experiments made with the thermoprobes SAK 1000 and KTY 11 resulted in inferior limit of sensitivity, and the transient time was at least ten times longer.

Construction of the RF circuit

The NTC thermistor must be directly glued to the load resistor (with very little two-part adhesive). However, due to its high sensitivity, it should be thermally decoupled from the input connector. Because mechanical stress from the inner conductor could destroy the chip resistor, it is not recommended that the load resistor is soldered directly to the RF connector. A good solution was found by using a 50Ω stripline in conjunction with a heat sink (brass plate) for connecting the load resistor to the input connector. This type of construction is shown in Fig 3.

In order to ensure a high cutoff frequency, the stripline should ideally be on a double sided PTFE material. A stripline width of 2.3mm will result when using 0.8mm thick RT/duroid 5870 material. In the author's prototype, the stripline is 12mm in length. Of course, epoxy PC boards can be used up to several GHz without problems since conductor length is non-resonant. When using 1.5mm thick epoxy PC board material, the stripline width is 3.1mm.

Special care must be taken at the transition between the coaxial connector and the stripline. Although N type connectors have better RF characteristics than BNC connectors, the former will exhibit a more noticeable discontinuity at the transition. Professional users specify SMA connectors up to 18GHz.

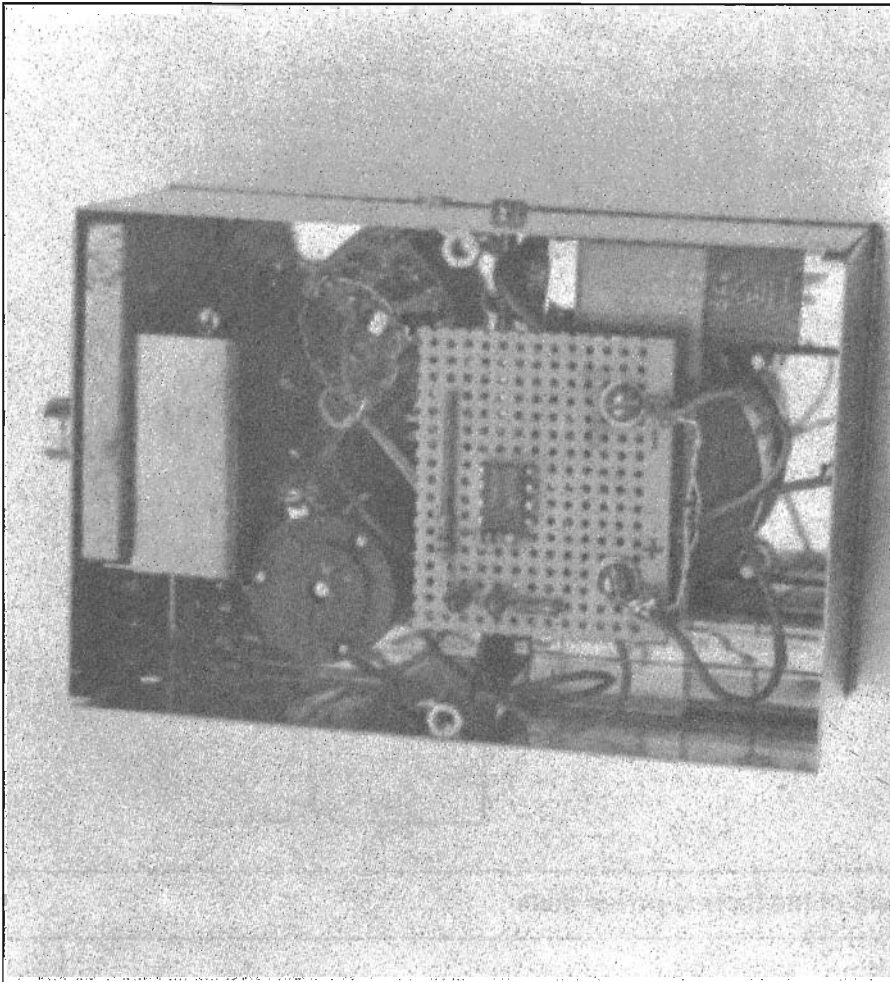

Fig 5: Photograph of the author's prototype. The RF portion is under the metal cover.

In order to achieve the shortest possible transient time for the bolometer, good heat dissipation is traded for maximum sensitivity. Heat conductive paste should be used between the stripline board and the brass heat sink and also placed around the chip resistor. Temperature fluctuations coming from the input connector are compensated for with the aid of a second brass plate (Fig 4). Since the thermal probe also reacts to the heat radiation falling on the case, the whole bolometer is surrounded in a metal case.

Any excessive solder on the stripline should be removed with a file in order to ensure a low heat delay. The NTC thermistor should be glued into position only after this has been carried out.

The fragile connection wires of the K19 thermistors are supported using feedthrough capacitors on the RF side and using a small board that has been glued into place on the temperature compensation side.

The author's prototype is mounted in a standard metal box measuring 111mm x 73mm x 50mm, see Fig 5.

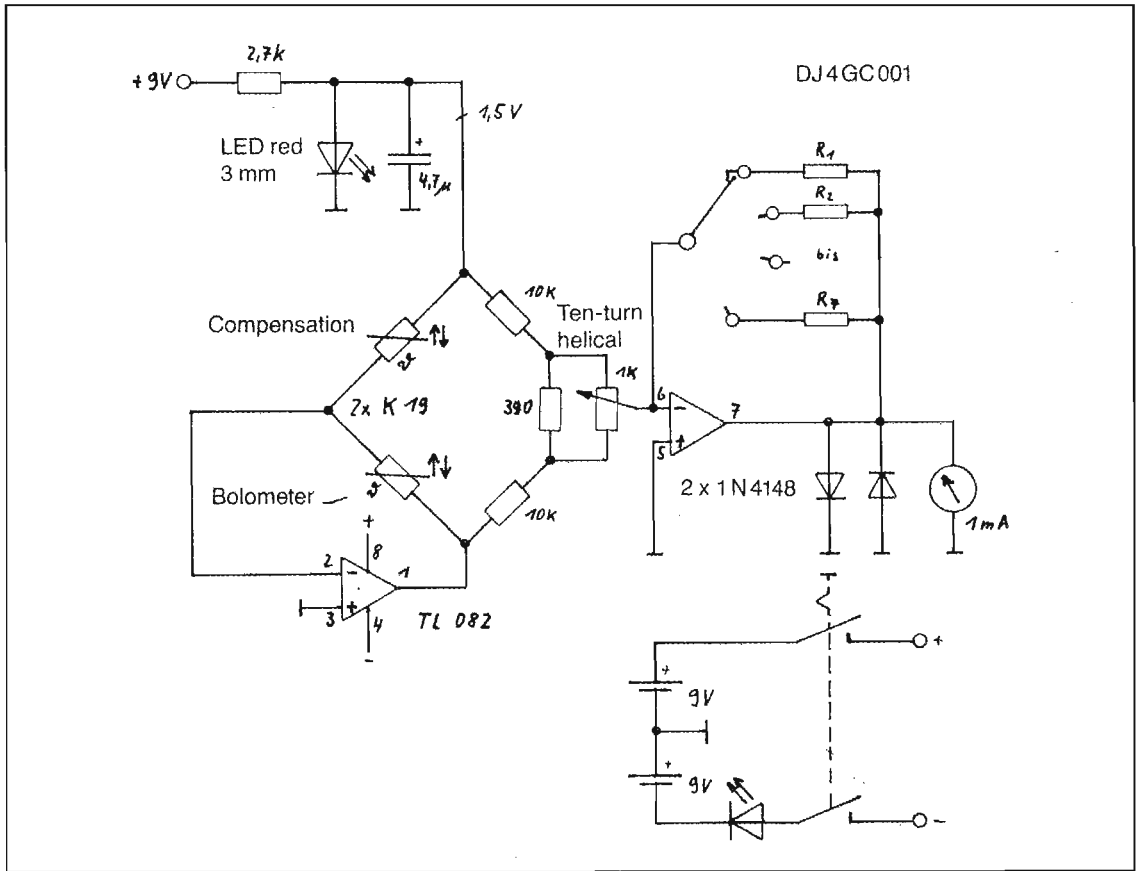

Fig 6: Circuit diagram of the thermo-power meter.

Measuring amplifier

In order to maintain the zero-point stability, and the calibrated meter sensitivity, it is recommended that a bridge circuit be used together with a second K19 (paired to have the same temperature coefficient), in order to compensate for ambient temperature fluctuations, (see Fig 6).

The first operational amplifier maintains a constant current via the test NTC thermistor, which allows a linear transfer of its resistance value to the actual test amplifier. The zero point can be adjusted before starting measurement using the ten turn helical potentiometer. If a larger case is used, it is possible to use cheaper coarse and fine controls.

The reference voltage is provided by an LED, which is connected as zener diode. Voltages higher than 1.5v will improve the sensitivity of the reading, however, will lead to considerable self heating of the thermal probe.

In order to change the measuring range, the feedback resistors of the second operational amplifier is switched.

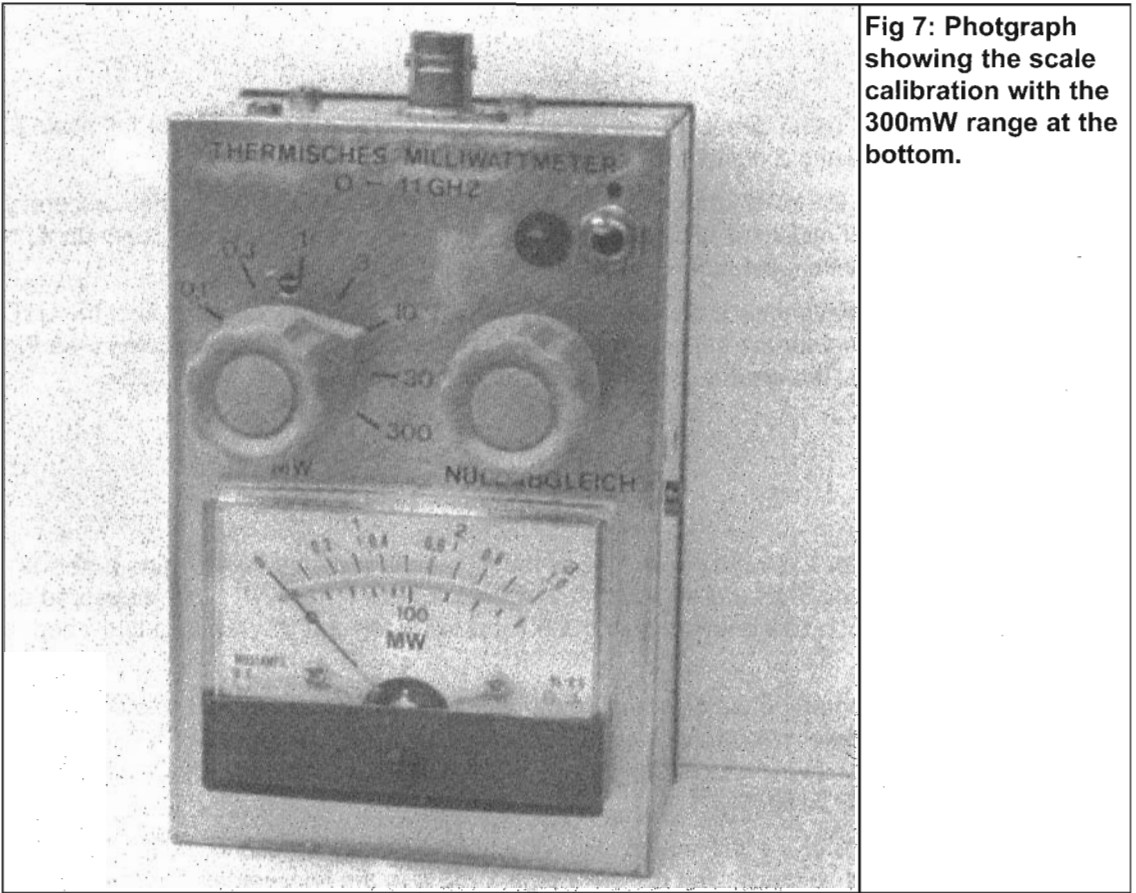

Fig 7: Photograph showing the scale calibration with the 300mW range at the bottom.

The resistance values and the measuring ranges (full-scale deflection) are:

R1	2.2M Ω	(0.1mW)
R2	680 k Ω	(0.3mW)
R3	220 k Ω	(1mW)
R4	68 k Ω	(3mW)
R5	22 k Ω	(10mW)
R6	6.8 k Ω	(30mW)
R7	1.4 k Ω	(300mW)

The meter cannot be overloaded because the operational amplifier has internal current limiting. Since input offset adjustment is not needed a low drift dual operational amplifier in an eight pin case can be used, such as the TL 082. In the most sensitive range, the flicker noise of the operational amplifier will cause a certain fluctuation of the meter reading.

The operating current is in the order of 5mA, which means that two 9v batteries can be used as power supply. The meter will also operate perfectly at $\pm 5v$.

Microwave Projects

Alignment

The meter is calibrated using direct current. It is advisable to adjust the current for full scale of the appropriate range using a digital meter.

The feedback resistors R1 to R6 of the test amplifier are selected to have the highest accuracy from a large selection of resistors. Since the sensitivity of the bolometer is greatly dependent on the mechanical construction, the values given are only for guidance.

Due to the non-linear relationship between the temperature and the resistance value of the NTC thermistor, it is necessary for the highest range of 300mW to be calibrated separately, (see Fig 7). On the 30mW range, the error is only a maximum of 4%, and should be acceptable.

Measured values

Before making the power the input return loss of the RF circuit was measured using a network analyser. A return loss of 20dB (corresponding to approximately 1.2 VSWR) was measured up to a frequency of 2.1GHz. The return loss of 10dB (approximately 2.0 VSWR) is only exceeded at 11GHz.

A 3GHz oscillator having an output power of 25mW with an accuracy of ± 0.1 dB was connected to the meter and this power was indicated with an accuracy of the meter needle. A Gunnplexer manufactured by Microwave Associates (15mW at 10.36GHz) measured 12mW after being adapted from waveguide to BNC.

The meter reaches 50% of the full-scale value after approximately 1 second. 90% of the final value is shown after 3.4 seconds. The transient time T (63% of the final value) is in the order of 1.5 seconds.

Practical experience

Due to the short length of the stripline used, there is some temperature sensitivity from the inner conductor of the input connector, because both NTC thermistors are not heated simultaneously. In the very low power range, it is advisable to work using an intermediate cable which remains connected to the meter. Otherwise, the zero-point stability is so high that it is not possible to carry out measurements directly after switching on. In the case of the two most sensitive ranges, it is advisable allow a warm up time of approximately three minutes.

The calibration was made at 20°C. A further test in a refrigerator at 5°C did not show large deviations.

The speed of the reading is approximately as fast as that of a dampened laboratory meter. Taking all advantages of this measuring system into consideration, it will be found that alignment work is not made more difficult due to too slow an indication.

The dynamic range of the power meter can be increased using wideband amplifiers,

attenuators, or directional couplers. However, the frequency range will be limited. It is possible, for instance, to use a directional coupler with an attenuation of 40dB to increase the measuring range up to 3kW. The exact value of the loss can be measured previously using this meter.

The high sensitivity of this meter, with a resolution in the order of $1\mu\text{W}$, also makes it possible to measure the frequency, or attenuation characteristics of filters, bandpass filters, directional couplers, frequency multipliers, mixers, low-signal amplifiers, etc. Its high dynamic range can be used right up to X-band.

A Grid-Dip Meter for VHF and UHF, Carl G. Lodstrom, SM6MOM

This design was entered in the first design contest held by Radio & Television in Sweden [7] in March 1975. It won second place behind a calculator programmable with a cassette recorder.

With twenty five years of hindsight this meter still seems to me like a good and useful instrument.

The commercial Grid-Dip (GD) meters, if available at all anymore, have not improved in sensitivity or internal resonances, or cost. However programmable calculators can now be purchased for a very reasonable cost.

The GD meter is as useful an instrument as ever, so it seems that this article can fill a need.

Introduction

The concept used is the same as the classical "Boon-ton" model 59 GD meter (Measurements Corporation, Division of McGraw-Edison, located in Boonton, New Jersey.) (Fig 12). The head is separate from the unit containing power supply and indicating meter.

This is by no means necessary, it can all reside in one box, as in the Millen, (Fig 13) but the advantage is that different heads, for very different frequency ranges, can be built and connected to the same one power supply and meter.

At the time I built mine it never dawned on me to use two 9v batteries instead of mains power! The consumption is so low that they should last "forever." Besides, better isolation, the absence of a mains lead and hum is worth a battery now and then.

The unit is shown complete with all the coils in Fig 8 whilst in Fig 9 the internals of the head with one side removed are shown and in Fig 10 is the complete circuit diagram.

Construction

Let me first recount the construction details and performance, as I remember them. I will also present suggestions that I have found in the fullness of time for improving upon the original weaknesses.

The size of the RF head depends on your needs (frequency) and what 2-gang variable

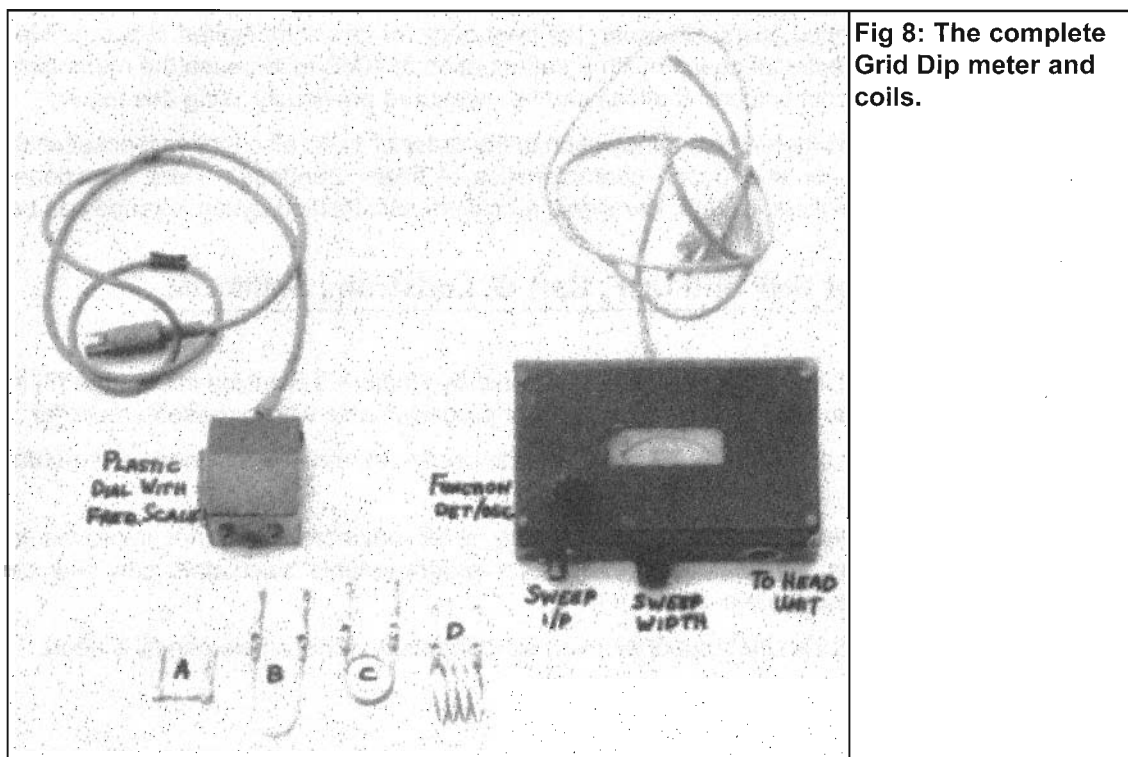

Fig 8: The complete Grid Dip meter and coils.

capacitor is available. One can even visualise use of capacitance diodes, which can make a very small head possible. The frequency read-out could be on another (or the same) meter, or on a dial on a potentiometer in the power supply box. The frequency range would be less for each coil due to the lesser capacitance range of Varicap diodes, but more coils are easy to make.

I have never seen a GD meter using Varicap diodes! Who will build the first one, and live to write an article about it?

I started "from the top", with the shortest coil I could make. "A" in Fig 8. The banana plugs connected by a straight brass tube. At first it did not want to oscillate at the higher end, so I had it silver plated, and that made all the difference. It got all the way up to approximately 420MHz.

As I see it now, getting so close to the 70cm band, and yet not covering it, should have resulted in the capacitor losing a few plates! 450MHz should be no problem to reach.

A few more coils followed. "C" followed "A", but since the 2m band ended up just about at the end of each, I also made "B" to centre it on the dial. The low end of "D" got down to 50MHz where the transition from DET to OSC function no was longer nice and smooth, no doubt due to there being more gain in the transistor at lower frequency and the Q of the coils getting higher.

This combination does not allow for an "almost oscillating" state. Smaller coupling capacitors than the 100pF used should help, values between 1 to 10pF may be enough.

A small capacitance in parallel with the source resistor would also give a more pronounced gain at higher frequencies, and maybe they can be balanced to provide a smooth operation over a

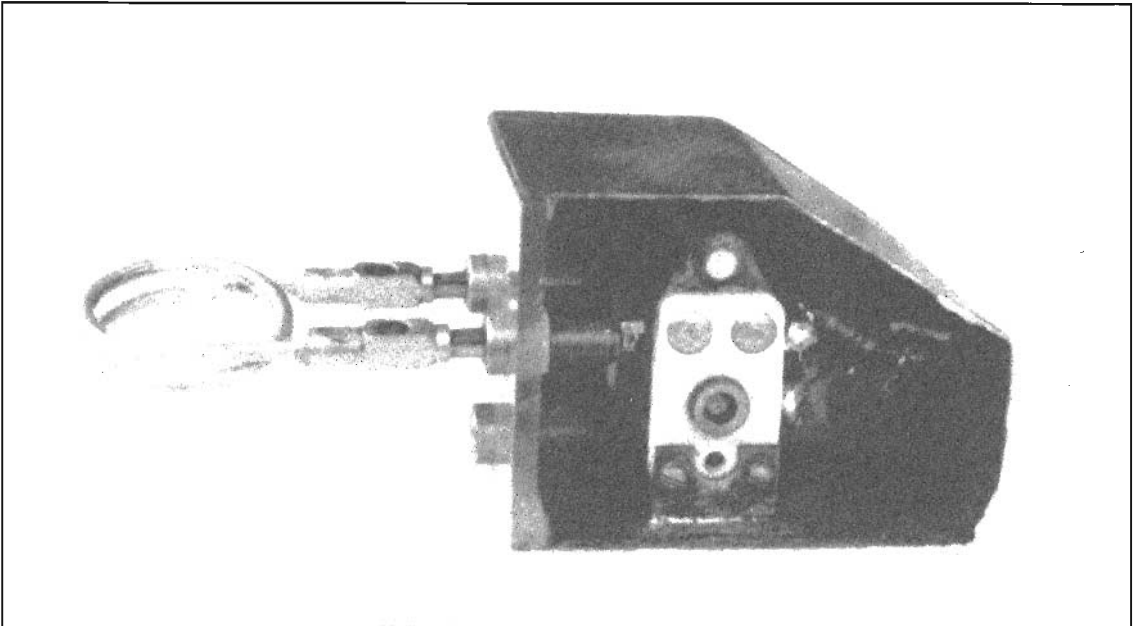

Fig 9: The head unit of the Grid Dip meter with side plate removed.

larger range. If everything else fails, the lower frequency coils can be fitted with a resistor in parallel, or be made smaller, leading to a lower Q. A value for Q of 50-100 is about all that is needed anyway.

The shaft from the variable capacitor got “hot” even though it was grounded to the frame of the capacitor. Therefore it was necessary to use a plastic dial and knob. At first I had a metal dial, but the frequency changed when I touched it.

One key in reaching high frequencies without problems is the efficient decoupling after the 47k Ω resistors. I used disc capacitors, filing down one side of each to reach the metal of the wire and then soldering them both direct to each side of a piece of sheet copper that is also soldered to the centre divider/ground of the variable capacitor. As we have seen in the article I wrote recently for VHF Communications [11], capacitors become resonant, and are then not worth much for decoupling at higher frequencies.

For 450MHz, the inductance in a 1nF capacitor will have to be on the order of 0.1nH. That is not possible unless the leads are completely eliminated, or kept to 0.15mm total length! 72pF surface mount capacitors of standard size, 3.2 x 1.6 mm, should be resonant at 450MHz and may help if they can be fitted.

The J-FET transistor has parametric capacitances that make it possible to “VCO” the GD meter. The gate bias can be varied a little with the sawtooth sweep from an oscilloscope or a function generator (see Fig 11). The stability was quite sufficient to sweep a regular narrow band FM radio and the linearity was good enough to sweep a broadcast FM radio. Markers can be obtained by letting a signal generator or a source rich in harmonics [8] interfere with the swept signal. It is valuable to add a potentiometer so the width of the sweep can be adjusted. An audio logarithmic potentiometer would be a good choice here.

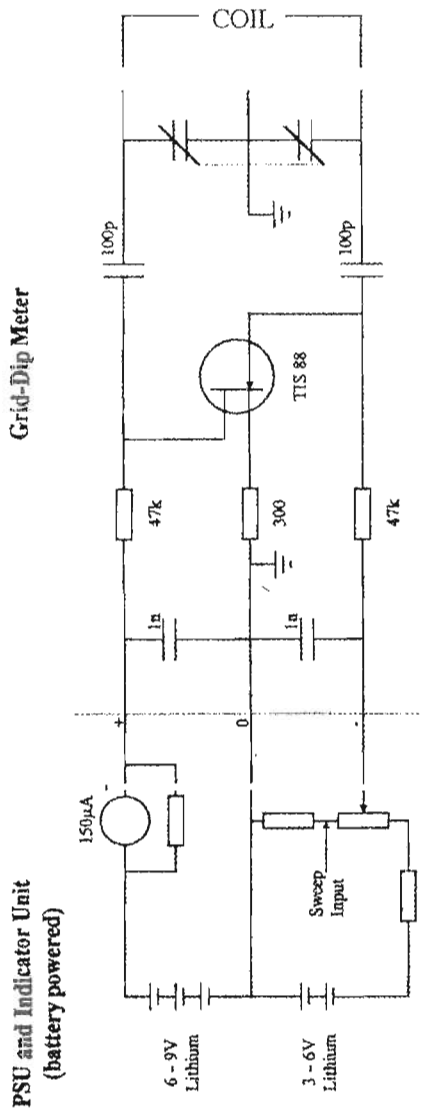
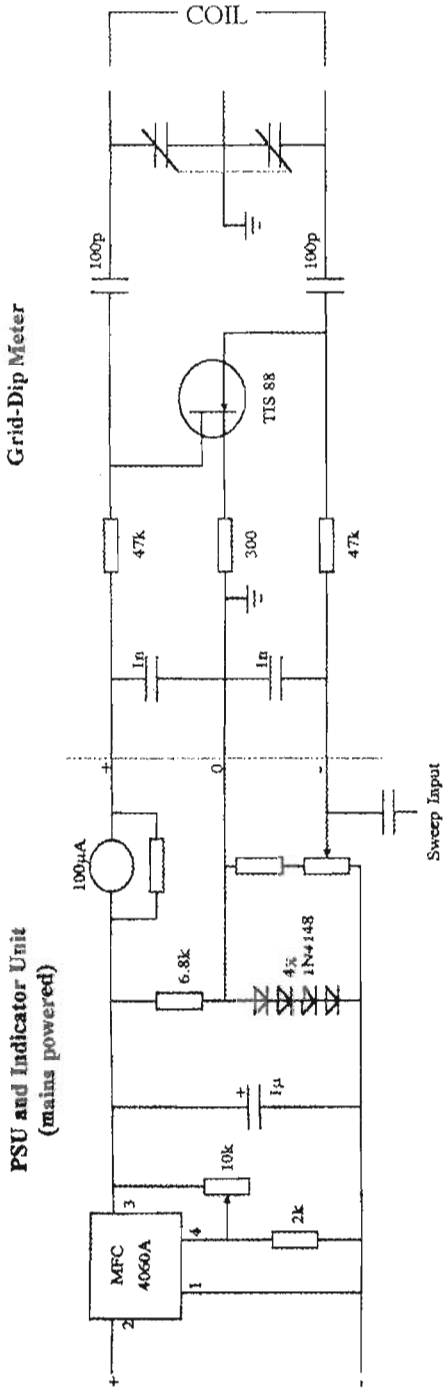

Fig 10: The circuit diagram of the Grid Dip meter.

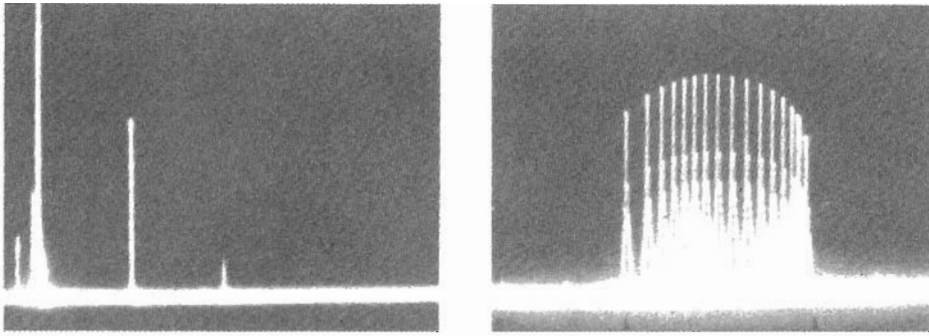

Fig 11: Left, the meter in OSC mode at 145MHz showing the harmonic content, 2nd harmonic -30dBc. Right, the meter in OSC mode at 145MHz using coil B with a 50Hz triangular wave signal at the sweep input.

If you base a design on capacitance diodes, the way to sweep the oscillator is obvious. Consider a little audio transformer in the drain lead in series with the μA meter. It can even be swept in the detector mode!

Operation

An unusual feature of this GD meter is the transition from DET to OSC function. It is usually a "hard" switched function, either or. In this unit the transition portion is even more sensitive to external fields of the same frequency, improving the sensitivity of the DET function. It even works as a detector while oscillating slightly.

Another unusual function is that at the bottom of the DET position the instrument is shut off! Once the J-FET is cut off, the current consumption is zero! The only thing consuming current is the potentiometer dividing the negative bias for the gate. This can very well be a 2 - 10M Ω pot, and will probably have to be put in series with top and bottom resistors anyway to provide the -2 to -4V bias, or whatever just makes your transistor happy and behave correctly.

Assume a partially discharged battery at 8v for this and a 4.7M Ω potentiometer. Assume also a desired range of gate bias from -2 to -4V. The potentiometer will have to be put in series with 2.4M Ω on top and 4.7M Ω at the bottom for a total of 11.8M Ω and a consumption of 678nA from 8v, 5.94mAh after a year...!

The other battery will be drained 50 - 100 μA , but only when you use the meter in oscillator mode. So it will also last "forever".

Now there are some very nice Lithium batteries [9] available with a capacity of about 1Ah and no leakage. The terminal voltage soon drops to 8.5v, but then drops very slowly over its life to 8.0v. Don't forget to change it after some 168 years! With a 750k Ω load they should last 10 years!

We have truly reached the age when electronic equipment just can be left on for years between

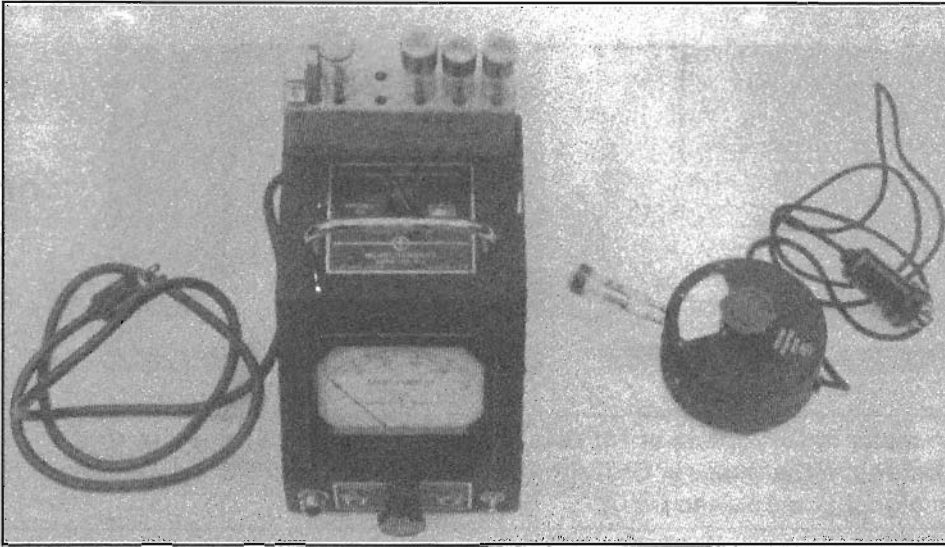

Fig 12: The classic Boon-ton model 59 Grid Dip meter.

change of batteries! Over 8v at $57\mu\text{A}$ can be supplied for two years by one battery like this.

So you have an instrument with the three functions in one potentiometer, DET/OSC switch, sensitivity control and the ON/OFF switch!

The nicest operational range was found to occur with the drain current in the range 0 - $150\mu\text{A}$, so a $100\mu\text{A}$ meter system was shunted a little. You may have to experiment, but start out with a 50 or $100\mu\text{A}$ meter, it is easy to shunt them, but not so easy to make them more sensitive!

Readers are no doubt very familiar with the uses of GD Meters, so I will not try to "preach to the choir". The purpose of this article is to inspire the building of them by those of you who have less than good working ones. If so, it can probably be re-built along these lines. Half the job, coils, dials and meter will already be completed!

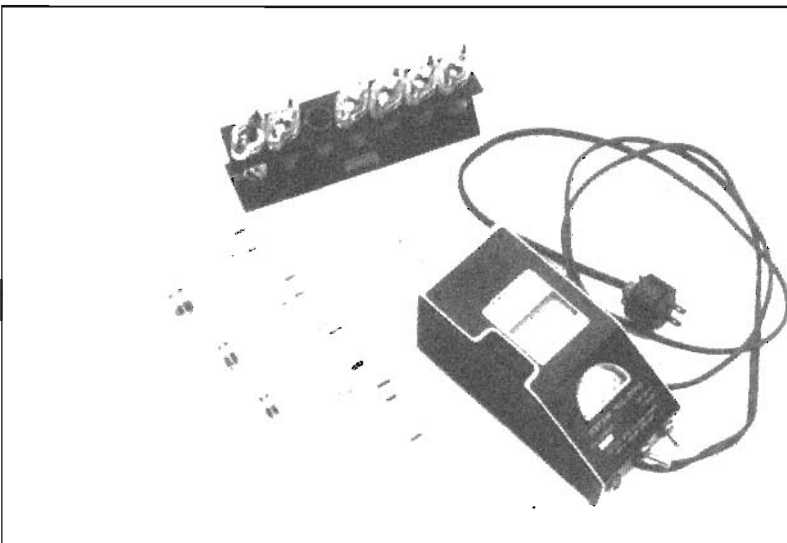

Fig 13: The Millen 90651 Grid Dip meter.

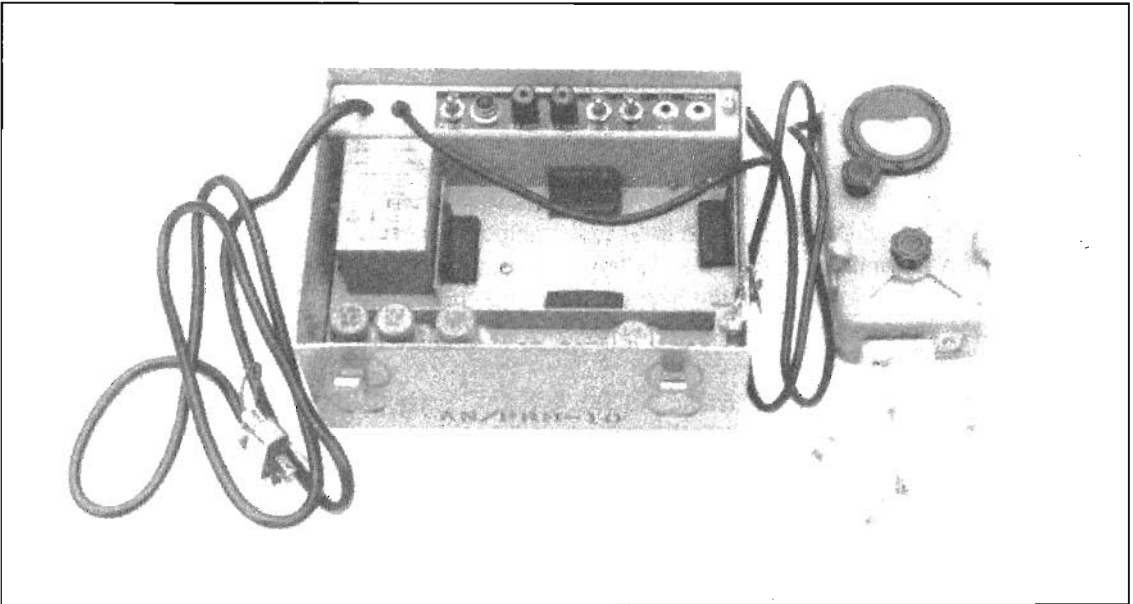

Fig 14: The AN/PRM-10 ex military Grid Dip meter.

Historical references

For reference, Figs 12 and 13 show two classic grid dip meters and one less well known, outside the USA at least, in Fig 14.

The Millen (Fig 13) could have benefited from the coil pins, sockets and the grounding wipers of the rotor in the variable capacitor being silver plated. It sometimes functions erratically, but otherwise basically functions well, head and shoulders above Heathkit and Eico, who have polluted the market with barely usable instruments.

I have a vague school memory from some 35 years ago, of a Grundig unit, with coils in green plastic housings. I am not sure it was all that great either, but better than the worst. They made great radios though! I have a couple.

The Measurements Corporation, "Boon-ton", Model 59 is the classic GD meter of all times! (Fig.12). The set pictured is a sight rarely seen, a complete set of 59 LF, 59 and 59 UHF, with manuals! I found it some 9 years ago at the annual Ampex Fleamarket in Redwood City, California, for a few hundred dollars! Once home I found that it had barely been used. All the seals intact, no bumps, scratches or dents, the dials are very accurate and it functions flawlessly. It is the GD meter to top all GD meters. The 59 LF covers 100kHz to 4.5MHz with 4 coils. The next head, the most common, covers 2.2 to 420MHz with 7 coils. The 59 UHF head covers 420 to 940MHz with one fixed coil.

Fig 13 shows the Millen. The wooden box is probably home built. The coverage is 1.7 to 300MHz with 7 coils. There is no sensitivity control, all the action of the meter takes place within

Microwave Projects

the limits of the dial. It is a bit "lame" on the 140 - 300MHz range, and silver plating the entire little loop coil would most certainly cure this. Not commonly found are the four extra coils on the right in Fig 12. They cover 225kHz to 2.05MHz. Like the others, the Millen GD meter contains a triode, 6C4 if I remember rightly. The "Acorn" tube 955 is used in the two other GD meters.

Fig 14 shows a military GD meter, built by Stamford Electronics Co., Connecticut, USA. AN/PRM-10. It covers 2 to 430MHz with 7 coils. It is very accurate and has good sensitivity and is flat over each band. Contributing to this is probably a fairly complicated system of resistors in each coil and a potentiometer coupled to the tuning capacitor. The coil plugs are silver plated, as are the entire coils for the highest frequencies. This meter can be found at the sales here for \$60-100 and is well worth its price.

A Sinadmeter, E.Chicken MBE, BSc. MSc, CEng, FIEE, G3BIK

Introduction

This easy to construct test meter simplifies measurement of the 12dB Sinad Sensitivity of an fm receiver.

It connects to the receiver's loudspeaker terminals to automatically display the Sinad measurement.

Power is taken from an external mains/dc unregulated 12V or 15V adapter @10mA or from the receiver's dc supply.

When using the Sinadmeter for measurement of a receiver, it must be used in conjunction with an fm signal generator of the type that has a modulating tone of 1kHz with adjustable deviation, and a voltage output control calibrated in microvolts rms. That type of signal generator is fairly standard to those who are involved with fm radio equipment, so should be reasonably available.

A very useful secondary feature of this Sinad meter is that it can be used as a sensitive response indicator whilst tweaking for optimum sensitivity (maximum quietening) the rf, mixer, and local oscillator stages of an fm receiver. This is of particular advantage for example when retuning an ex PMR receiver for use on the amateur bands.

Sinad Explained

The Sinad sensitivity of an fm receiver is expressed in microvolts rms, and is derived from an internationally accepted method for determining the sensitivity of the receiver.

Sinad is a ratio expressed in dB, which relates the level of a 1kHz audio-tone output from the loudspeaker, to distortion and noise generated within the receiver, using the formula:

$$\text{SINAD (in dB)} = \frac{\text{Signal plus ***Noise And Distortion***}}{\text{Noise and Distortion}}$$

Note that the term Signal refers to the 1kHz audio-tone output from the loudspeaker, not the rf input signal!

The 12dB Sinad Sensitivity figure which is expressed in microvolts rms (not as Sinad dB), is the accepted standard of Sinad measurement against which to judge the sensitivity of an fm communications receiver. It is defined as that level of microvolts rms (pd) rf signal into the receiver's antenna port, which produces at the audio output a Sinad ratio of 12dB. At this sensitivity the receiver would give an intelligible voice signal on an acceptably quiet background. Any modern communications receiver will have a 12dB Sinad Sensitivity in the order of 0.5 microvolt rms or less.

Strictly speaking, the definitive method of Sinad measurement requires that:

- the rf signal being fed into the receivers antenna terminal be frequency-modulated by a 1kHz tone with deviation to 60% of the receiver's specified peak deviation.
- the Sinad meter must incorporate a 1kHz band-rejection filter.
- the Sinad meter be connected across the receiver's loudspeaker or an equivalent load.
- the audio output power should be at 50% of rated maximum when the Sinad meter indicates 12dB.

But, for the 5kHz peak deviation typical of today's amateur-band receivers, that definitive method simplifies to become a 1kHz modulating tone at 3kHz peak deviation from the signal generator. Its microvolts rms level will be in pd because the receiver's input impedance will in normal practice match that of the signal generator.

This design does incorporate the required 1kHz band-reject filter, and for practical purposes, the Sinad meter can simply connect to the external loudspeaker terminals with the volume set to a comfortable listening level.

Bear in mind that (in simplistic terms) for a changing voltage level of tone-modulated rf signal feeding into an FM receiver, the audio level of the receiver's output tone remains sensibly constant, but the noise level changes. As the level of the incoming rf signal *decreases*, the background noise *increases* to the point where the tone-signal is totally swamped to inaudibility. As the level of the incoming rf signal *increases*, the noise level *decreases* until the tone-signal is on a noise-free background.

That latter feature is exploited in the design of this Sinad meter with its 1kHz rejection filter, to give a near zero reading on the meter in response to a noise-free tone signal from the loudspeaker, and full-scale reading for a noise-maximum inaudible-tone signal. Between these two extremes, the intelligibility of a voice signal from the loudspeaker would vary from excellent to impossible. The meter response is acceptably linear, hence can readily be calibrated in -dB intervals. By assigning a value of 0dB to full-scale deflection, and in the knowledge $-12\text{dB} = \times 0.25$, then for a meter-scale marked 0-100 μA , fsd (100 μA) = 0dB, 1/4 scale (25 μA) = 12dB, minimum-scale (approximately 10 μA) = approximately 20dB. Once calibrated, only the 12dB marker is of real importance.

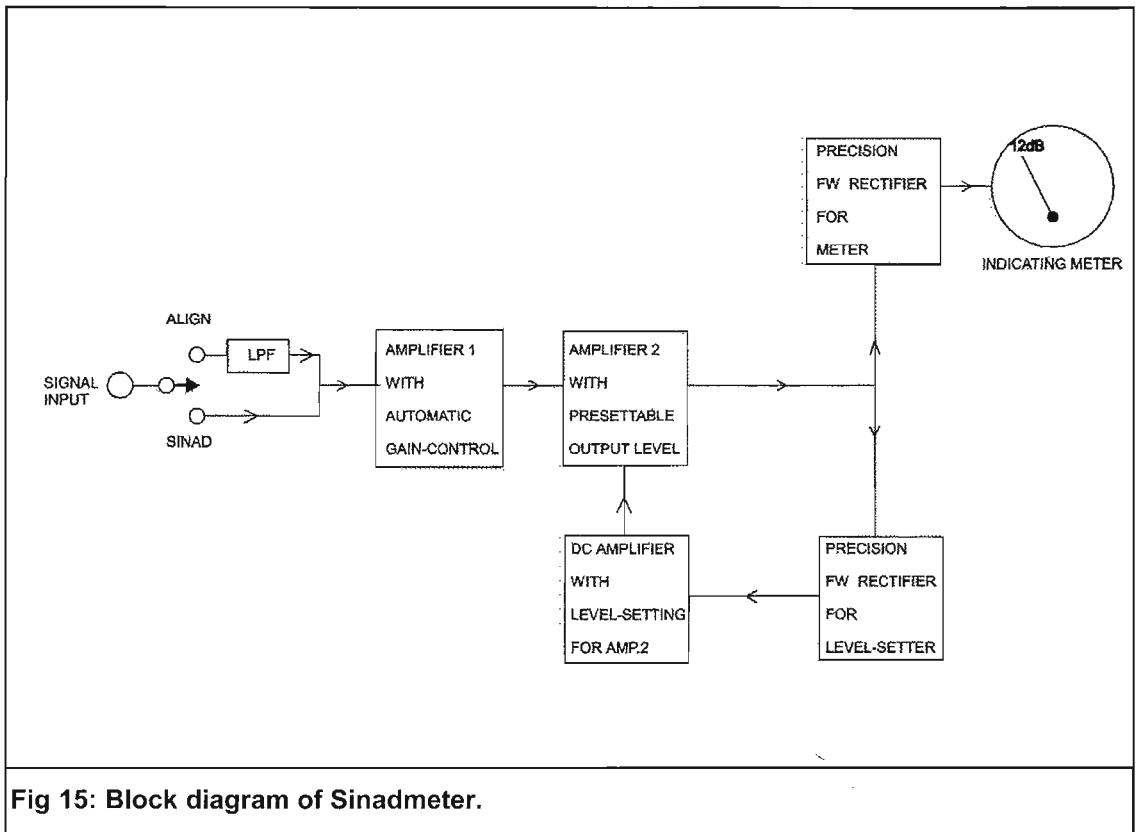

Fig 15: Block diagram of Sinadmeter.

Circuit Description

The Sinadmeter is fully automatic in use. It has one pair of input leads which connect to the receiver's loudspeaker. With its internal +12V dc regulator, it requires a single dc input of 13-15 volts at about 10 mA, which could be obtained from a 12v or 15V unregulated mains/dc adapter or from the receiver's nominal 13.5V supply.

Figure 15 shows the circuit in block diagram form, and the full circuit detail is given in Figure 16.

The circuit consists of two audio-frequency amplifiers in cascade which feed, via a 1kHz reject filter into a full-wave rectifier, to drive an indicating meter calibrated in Sinad dB. Low-cost quad op-amps are used rather than expensive Vogad ICs. The first amplifier formed by IC1A and IC1B incorporates its own automatic gain control (agc) circuit. This is used to feed a constant level of output signal voltage to the second amplifier, from an input signal level of between approximately 100mV and 3V rms which is taken directly from the loudspeaker. The second amplifier IC1C incorporates a pre-settable gain/level-set control RV4, which allows a degree of manual control to the overall agc. This combination of automatic and manual gain control ensures a constant preset level of audio signal being fed to the meter's precision full-wave rectifier circuit, irrespective of the level of input signal to the Sinadmeter over the given range. This allows the meter scale to be pre-calibrated in dB for fully automatic response in use. The

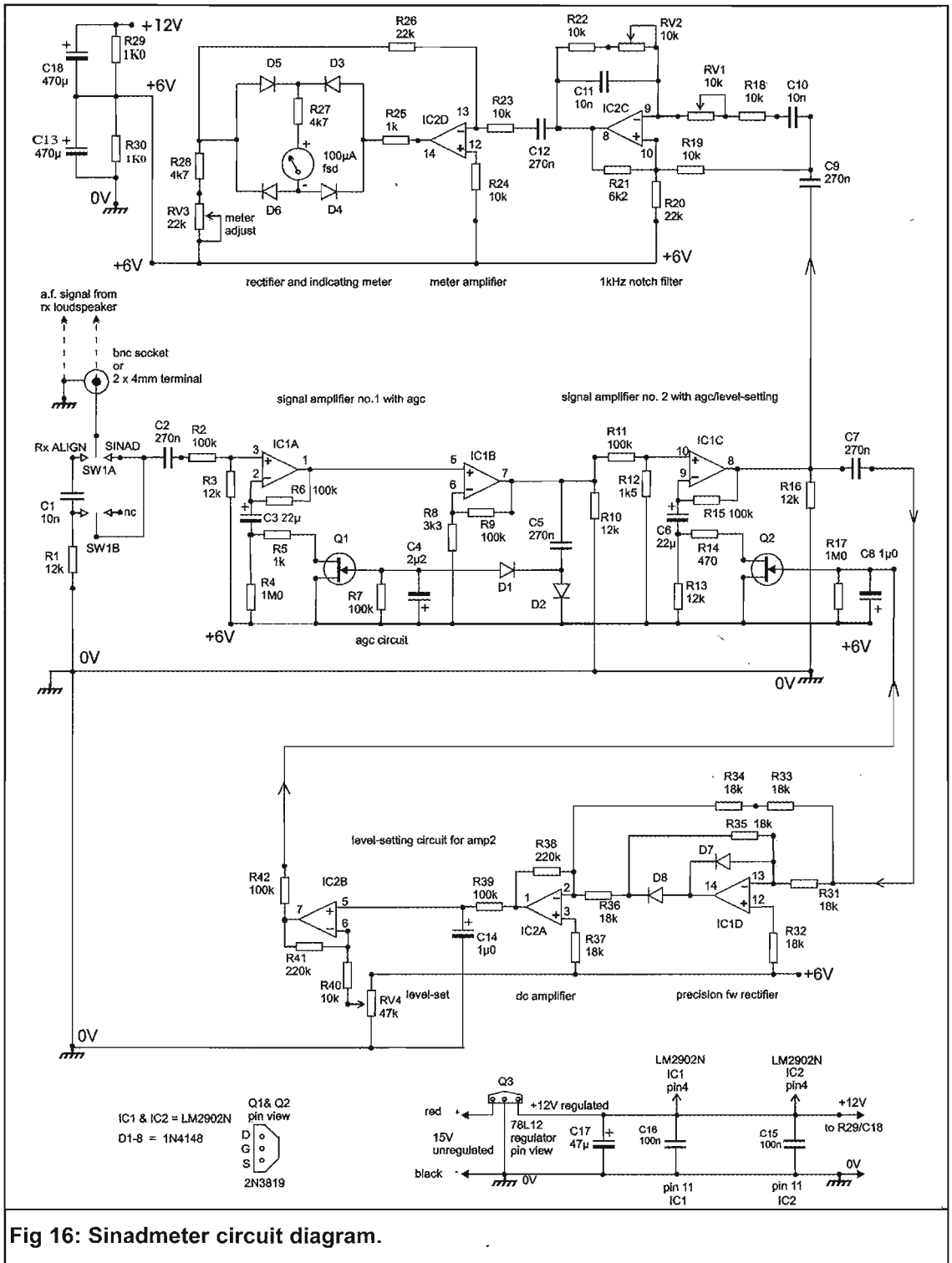

Fig 16: Sinadmeter circuit diagram.

Microwave Projects

level-set control RV4 pre-sets the ac output-level of IC1C, hence the input into IC2D meter-amplifier/rectifier, to give a full-scale deflection on the meter for a totally noise signal i.e. the receiver on open squelch with no rf input signal.

The gain-control in each of the two signal amplifiers is similar in principle, in that some of the ac output signal is rectified to be fed back as a dc control voltage to the gate of a field effect transistor. The fet then acts as a variable resistor in the negative feedback loop of the amplifier, to adjust the gain such as to hold the output signal constant at a prescribed voltage level. The gain-control of the first amplifier is fully automatic, but that of signal amplifier no.2 is manually adjustable by RV4.

The amplified ac output signal from IC1C is a reasonably faithful reproduction of the audio signal from the receiver's loudspeaker terminal. It feeds via C9 into the 1kHz reject/notch filter formed around IC2C. Meter amplifier/rectifier IC2D is therefore fed only with the noise and distortion, the 1kHz tone content of the combined Signal+Noise+Distortion having been removed by the preceding reject filter. Preset resistors RV1 and RV2 tune the notch filter to 1kHz, and are simply adjusted to produce a minimum deflection on the meter, using the 1kHz tone signal from the signal generator feeding into the receiver at about 1000 μ V rms to produce a noise-free tone . Like RV4, this is a once only adjustment.

The precision full-wave rectifier based on IC2D has within its feedback loop, the rectifier-bridge diodes D3,4,5,6, and the 100 μ V dc meter, and the meter-adjust RV3 , hence any change to the given component values will affect the meter deflection. RV3 was only included to allow some degree of choice on the available full-scale deflection of meter, other than the specified 100 μ A. It is optional and could be replaced by a fixed 10k Ω resistor, because the level-set control RV4 allows adequate control of full scale deflection on the meter.

Also optional is the input low-pass filter formed by C1/R1, and associated switch SW1ab. The switch has the legends Sinad and Align. In the Sinad position, the low-pass filter is by-passed. The filter is switched into the input signal path when in the Align position. This is to smooth out any slight flicker of the meter needle as it responds to receiver noise, whilst using the meter as a tuning aid when adjusting the tuned circuits of a receiver's rf/local oscillator stages.

Construction

Details are provided for assembly on either copper stripboard (Figures 17&18) or pcb (Figures 19&20). Stripboard is perhaps the most convenient choice for the home constructor. The most critical part of stripboard assembly is the cutting of copper tracks, but the track-cut template of Figure 18 should simplify that task. To use the template, fix a photocopy of it to the stripboard with the image visible, using a drawing pin in each corner hole to locate it correctly, then secure with sticky tape and remove the pins. Use the track-cutting tool to *partially* cut through each marker in turn. Remove the template to reveal the now clearly visible cutting locations, and complete the cutting process at each hole. The photocopy may need to be scaled to size.

Before installing components, carefully check that each track-cut is absolute! This is best done using a powerful magnifying glass, and/or a continuity-test buzzer applied across each cut in turn. The time spent on this routine more than justifies the effort! Be sure also to check for

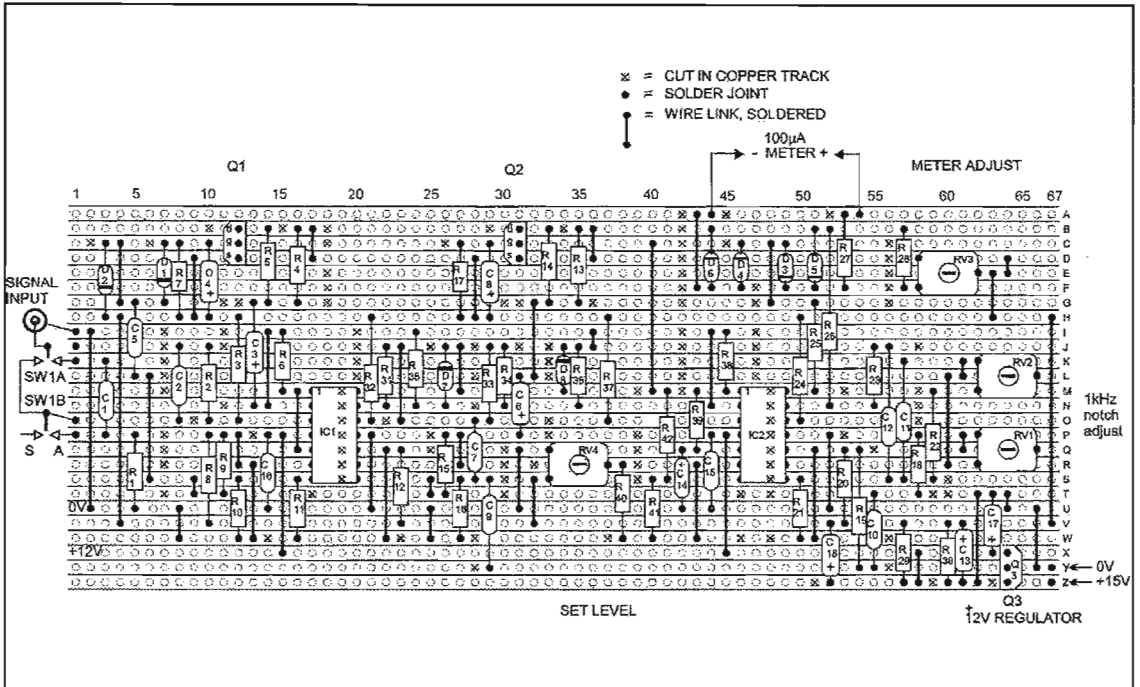

Fig 17: Sinadmeter stripboard layout for wiring and components (non-copper side).

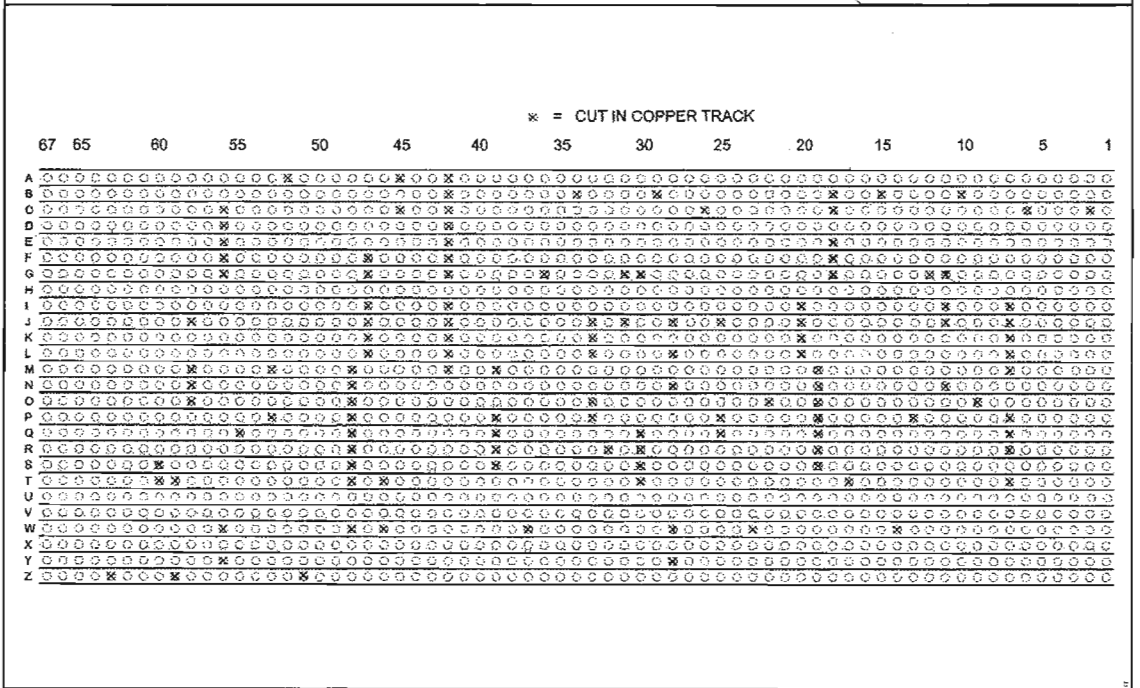

Fig 18: Sinadmeter stripboard track cutting template (copper side).

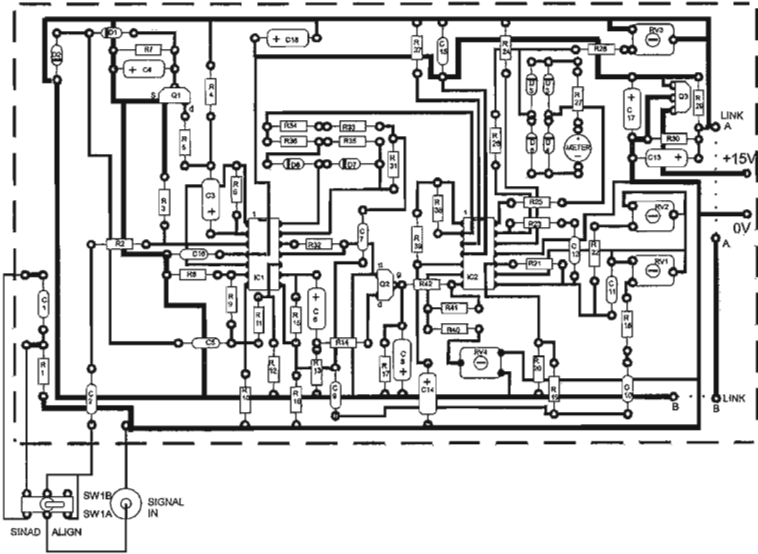

Fig 19: Sinadmeter PCB component side.

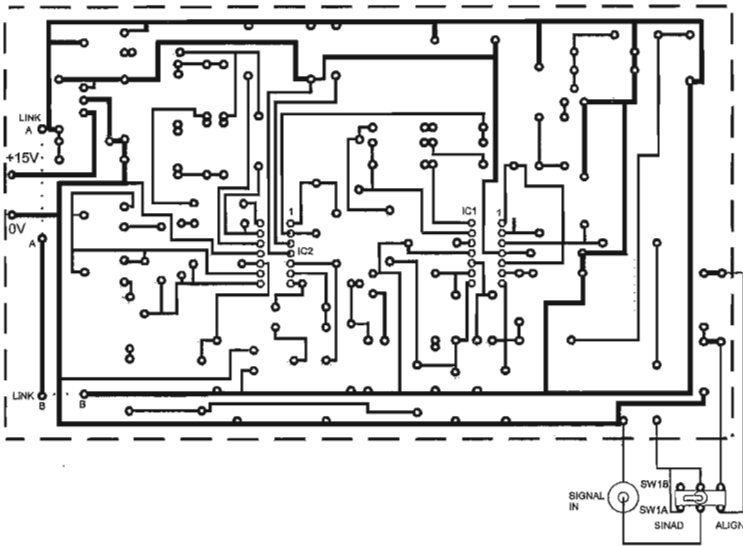

Fig 20: Sinadmeter PCB copper side.

absence of short-circuits between the 0V, +6V, +12V, and +15V rails. Now apply dc and check that the regulated +12V is available. Disconnect the dc supply, insert IC1 and IC2, then set RV1,2,3,4 to mid-position.

For housing the unit, a plastic container would be suitable. Screening of the sinad signal input leads is not necessary.

Setting-up and Calibration

This requires a low-frequency sine-wave source covering 300Hz-3kHz with a variable 0-3V rms output.

RV1,2,3,4 are at mid-position. Connect the Sinadmeter's input leads to the low-frequency source, with its output set to exactly 1kHz at 1volt rms level. Reconnect the power supply to the Sinadmeter, and observe some movement of the meter. Adjust RV1 and RV2 successively for minimum deflection on the meter, which should be near the 10 μ A reading. This proves that the 1kHz reject filter is functional. Swing the frequency either side of 1kHz, say to 300Hz and 3kHz, and the meter should rise towards full-scale deflection. With the frequency at 2kHz, adjust level-setting control RV4 to give exactly full-scale deflection i.e. 100 μ A. Vary the output level of the low-frequency source from zero to about 3V, and observe that the meter deflection remains sensibly constant for input variation from about 100mV to at least 2V rms.

Finally, set up an fm receiver with an fm signal source connected to its antenna port. Set the signal generator to the receive frequency, with 1kHz tone-modulation at 3kHz peak deviation, and with its output level at about 1000 μ V rms.

Adjust the receiver volume control to give a comfortable listening level for the 1kHz output tone, which will be on a completely noise-free background.

Connect the Sinadmeter's input leads across the receiver's loudspeaker terminals, with the black lead to receiver chassis-potential. The meter should be at or about minimum deflection. Re-adjust RV1 and RV2 to optimise the Sinadmeter's reject filter to the rf signal generator's 1kHz modulating-tone.

Disconnect the rf signal source from the receiver, and open the squelch to produce full noise output from the loudspeaker. Readjust RV4 to give full-scale deflection of exactly 100 μ A. This should remain sensibly constant when the volume control is varied.

Meter-set control RV3 is still at mid-position, and there it should remain. As stated earlier, it might only ever be needed if a meter of other than 100 μ A is used. Hence, RV1,2,3,4 are now finally and forever set, and the Sinadmeter becomes fully automatic in use.

The only thing left to do, is to mark 12db on the meter -glass at its one-quarter full scale point i.e. at the 25 μ A position for a 100 μ A fsd meter. This is the 12dB Sinad Sensitivity mark against which all future receiver checks will be made. Remember, the receiver's 12db Sinad Sensitivity is the microvolts rms level from the signal generator that causes the Sinadmeter to read 12dB, typically 0.5 μ V or thereabouts.

Microwave Projects

Parts List for Sinadmeter

Qty	Description	Qty	Description
2	Quad-Opamp IC type LM2902N	Preset resistor, carbon, minimum horizontal pin spacing 10mm x 5mm	
8	Diode type 1N4148	2	10kΩ RV1,2
2	FET type 2N3819	1	22kΩ RV3
1	Voltage regulator 12V/100mA type 78L12	1	47kΩ RV4
Capacitor, electrolytic, min. axial 16V		Resistor, metal film, 0.25W	
2	1.0μF C8,14	2	470Ω R14
1	2.2μF C4	4	1.0kΩ R5,25,29,30
2	22μF C3,6	1	1.5kΩ R12
1	47μF C17	1	3.3kΩ R8
2	470μF C13,18	2	4.7kΩ R27,28
Capacitor, min.dipped, mylar/polyester film 100V dc		1	6.2kΩ R21
3	10nF C1,10,11	6	10kΩ R18,19,22,23,24,40
2	100nF C15,16	5	12kΩ R1,3,10,13,16
5	270nF C2,5,7,9,12	7	18kΩ R31,32,33,34,35,36,37
2	14pin dil socket	2	22kΩ R20,26
2	Terminal post, 4mm, small. One black, one yellow	8	100kΩ R2,6,7,9,11,15,39,42
1	Panel Meter, 100μA dc fsd , calibrated 0-10 or 0-100, e.g. Maplin 2inch RW92A	2	220kΩ R38,41
1	Switch, dpdt toggle sub-miniature, panel mounting	2	1.0MΩ R4,17
1	Stripboard, 0.1inch, copper, srpb, 170 x 75mm, 26 rows x 67 holes		
1	Stripboard track-cutting tool		
1	Low-cost plastic box with lid, eg Maplin BZ75S		

5GHz ÷10 pre-divider, Alexander Meier, DG6RBP

A frequency counter is part of the standard equipment in almost any radio-frequency laboratory, but the frequency range usually goes up to no further than 1.3GHz. Although almost all measurements are carried out within this range, we nevertheless often wish we could measure higher frequencies as well. As an alternative to purchasing an expensive microwave counter, there is the option of expanding the range of an existing piece of apparatus with an external pre-divider.

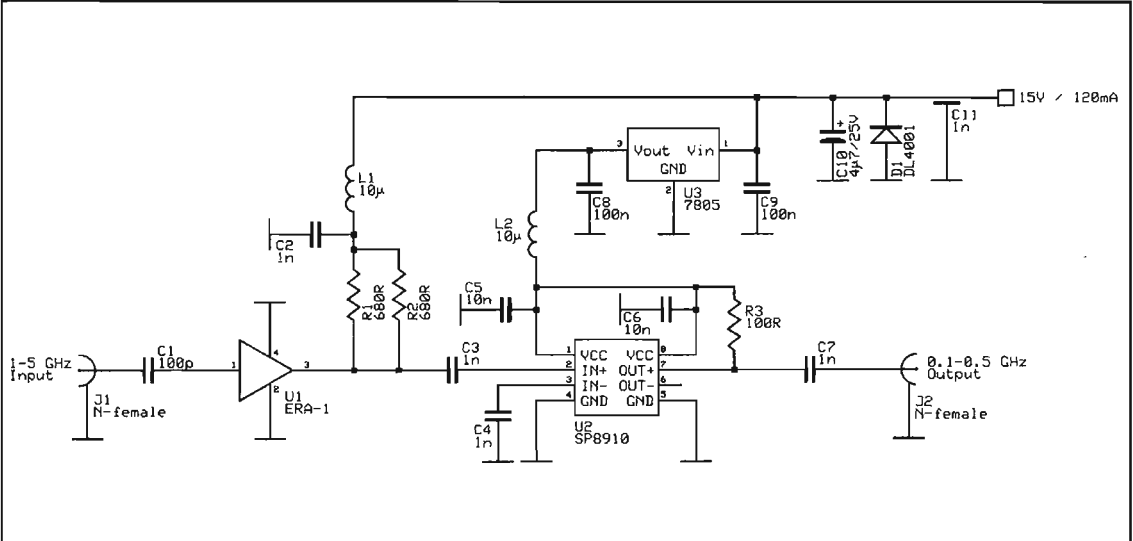

Fig 21: Circuit diagram of 5GHz pre-divider.

Circuit description

There are only a few components in the circuit of the pre-divider for frequency counters, Fig. 21 shows the wiring diagram. A similar pre-divider was presented a few years ago in [12]. Since the Plessey SP 8910 divider IC used has not been obtainable for some time, the project has tended to be forgotten. In the meantime, this IC has been brought back, and is currently available (once again) in a modern SMD housing from Zarlink [13]. So what could be more obvious than to

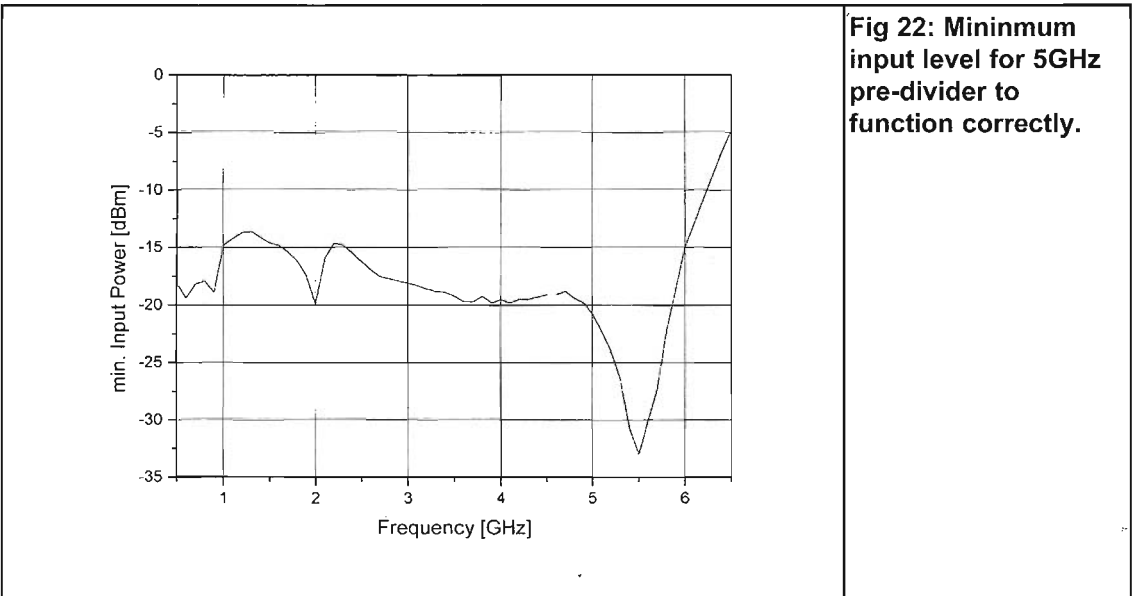

Fig 22: Minimum input level for 5GHz pre-divider to function correctly.

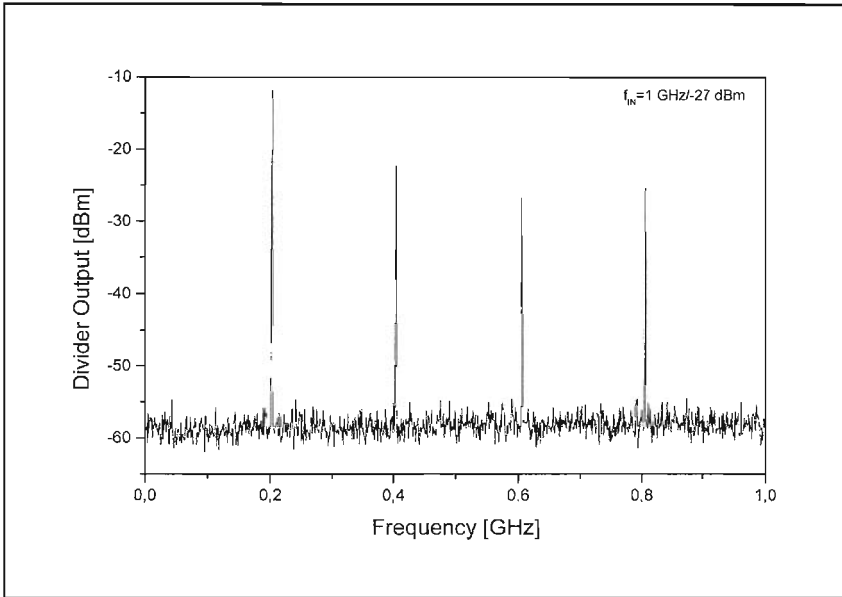

Fig 23: Output of 5GHz pre-divider when input level is too low (1GHz, -27dBm).

develop a new frequency divider using this IC?

At the pre-selector input of the circuit there is a very broad band ERA-1 amplifier from Mini Circuits [14]. It amplifies the input signal up to 5GHz with approximately 11 to 12dB, before the signal is fed to the actual divider, U2, at PIN 2.

Like other dividers, this one also oscillates without an input signal, in which case approximately 550MHz can be measured at the output. On some dividers, this oscillation can be suppressed by means of a resistance between the input pin and earth, but this was not successful here.

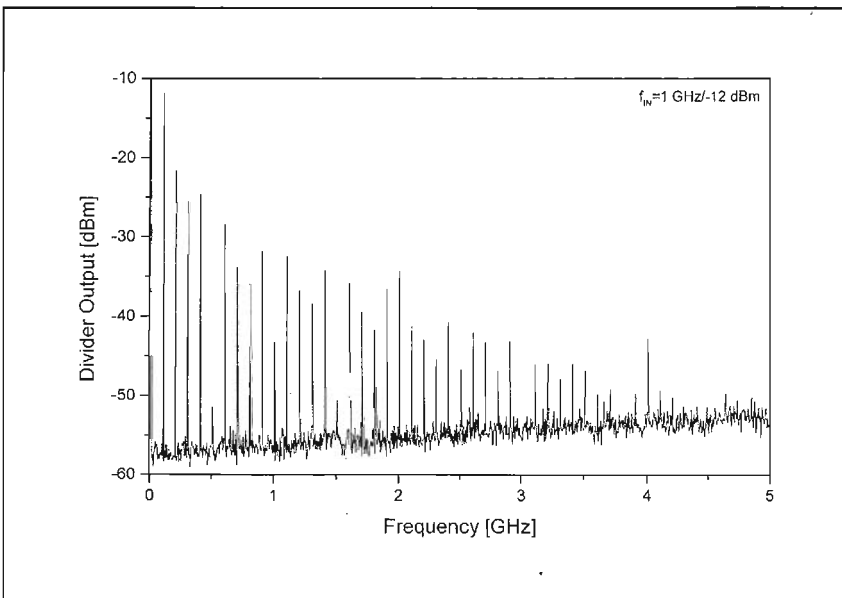

Fig 24: Output of 5GHz pre-divider when input level is correct (1GHz, -12dBm).

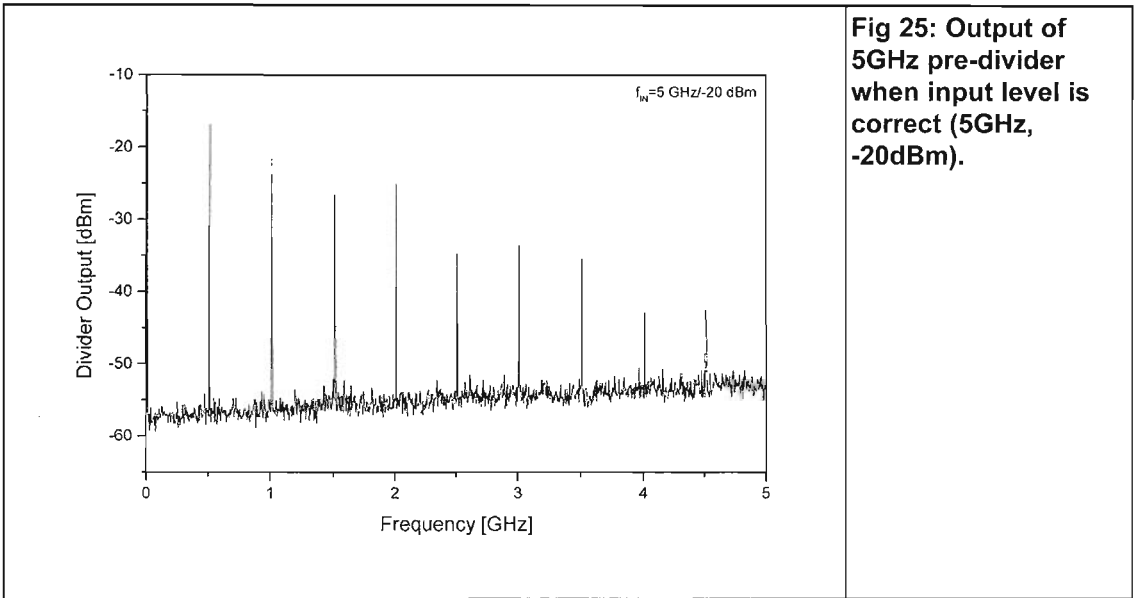

Fig 25: Output of 5GHz pre-divider when input level is correct (5GHz, -20dBm).

The resistor R3 provides for an output impedance of approximately 50 Ohms, and the output level is approximately -10dBm. But the required input level represents a greater problem. The curve in Fig. 22 shows how high the minimum level must be for the divider to function satisfactorily. We can also see that the divider can still be used over 5GHz. Be careful the input levels are not too low! Fig. 23 shows what happens at the output, with an input frequency of 1GHz, if the input level (-27dBm) is too low, an input frequency of 2GHz is faked! Figs. 24 and 25 in contrast show the spectrum at the output with the correct input levels. Input levels that are too high should likewise be avoided.

The supply voltage for the divider is stabilised with a fixed voltage regulator (U3). The one selected here was in a TO-220 housing.

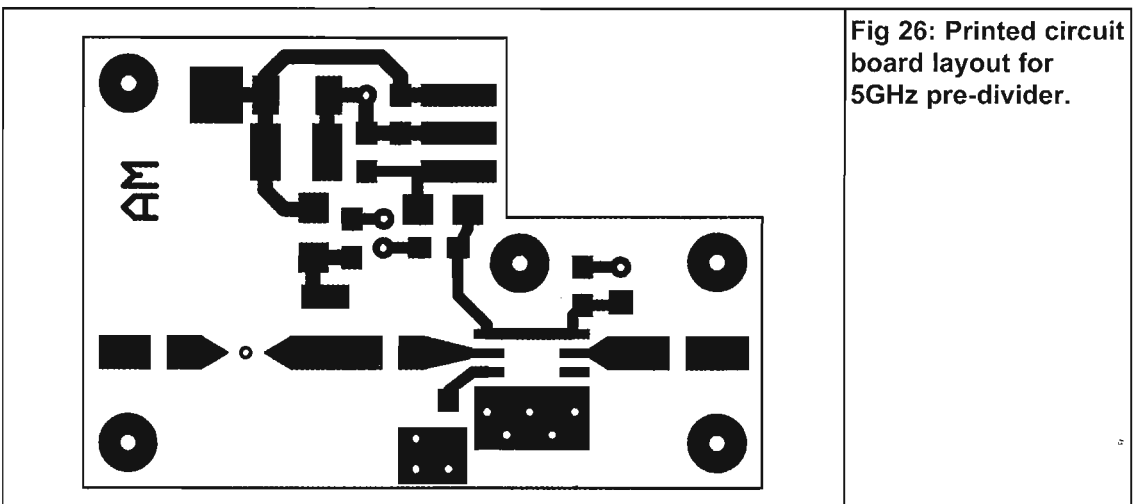

Fig 26: Printed circuit board layout for 5GHz pre-divider.

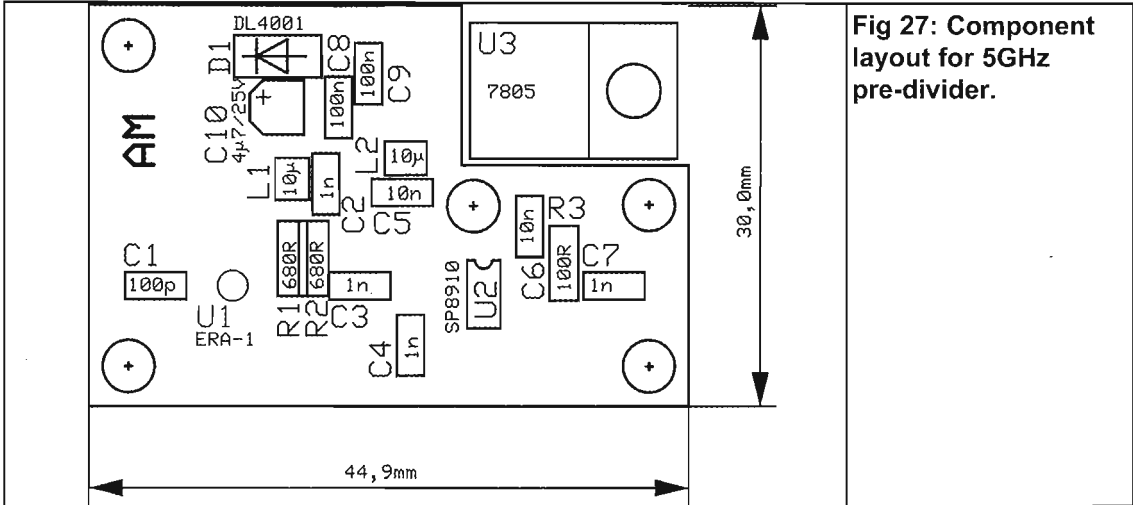

Fig 27: Component layout for 5GHz pre-divider.

Circuit assembly

The circuit is assembled on a 45mm x 30mm Teflon printed circuit board (Fig. 26). This has a gap at one corner for the voltage regulator, U3.

When building the printed circuit board in accordance with the component layout (Fig. 27), pay particular attention to mounting the amplifier U1. Its earth connections must be connected to the earth side of the printed circuit board by the shortest path, or it will have a tendency to oscillate due to the feed inductances arising.

Earth connections using through plating are not successful unless there is sufficient through connection. So another method is used here, which is always successful. The MMIC is sunk into a hole (Ø 2.3mm) in the board itself. The earth connections are bent downwards and soldered

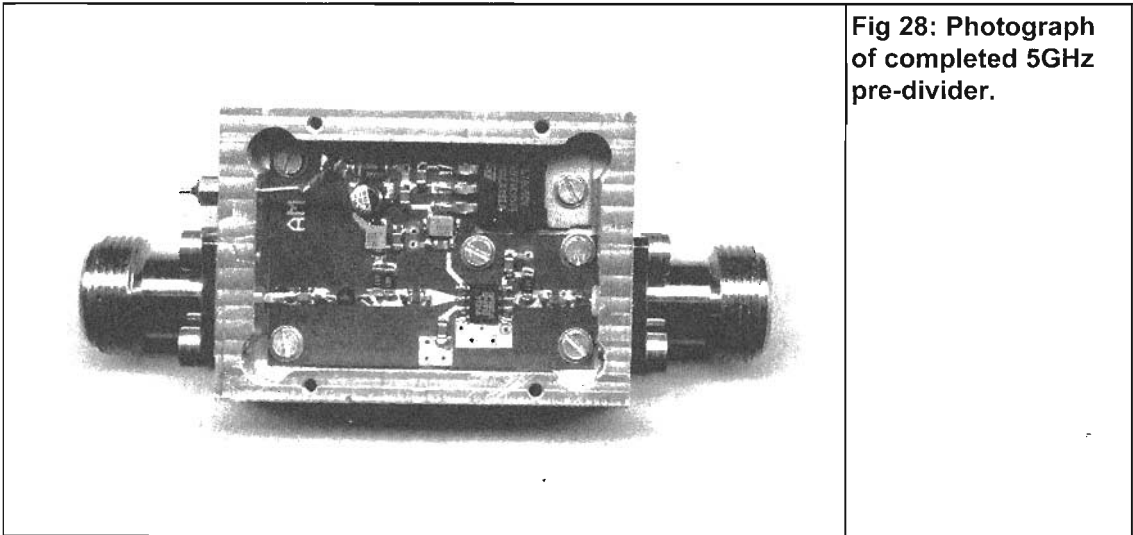

Fig 28: Photograph of completed 5GHz pre-divider.

Parts list for 5GHz divider.

U1	ERA-1	(Mini-Circuits)	R1,R2	680Ω	1206
U2	SP8910	(SO8, Zarlink)	R3	100Ω	1206
U3	7805		2	N-flanged sockets,	
C1	100 pF	0805		small 4-hole flange	
C2,C3,C4,C7	1nF	0805	1	Teflon printed circuit board,	
C5,C6	10nF	0805		DG6RBP 002, through-plated	
C8,C9	100nF	0805	1	Aluminium housing	
C10	4.7μF/25V	SMD	1	Soldering lug 3.2 mm for C11	
C11	1nF	FT capacitor		(earth connection)	
		M3 Actipass			
		AFC-102P-10A			
L1,L2	10μH	SMD			

Technical data for 5GHz divider.

Input frequency range	1 to 5 GHz
Output range	100 to 500MHz
Divider factor	10
Input level approximately	13 to 7dBm
Output level approximately	10dBm
Input and output connectors	N socket
Power supply	+15V, 120mA

flush with the earth surface. In the same way, the inputs and outputs are bent upwards and soldered to the tracks.

When the board has been fully populated (except for the voltage regulator), the flux residues are cleaned off the earth side and it is screwed into the milled aluminium housing. Then the voltage regulator and the connectors can also be fixed and soldered on.

Before the housing is screwed down, the top of the board should be cleaned again and the circuit should be tested. You should also make sure that U1 is not oscillating!

Directional couplers - made to measure, Harald Braubach, DL1GBH

It was always difficult for radio amateurs to construct wideband directional couplers having a low coupling attenuation. Microstrip couplers are easy to manufacture for those that have such capabilities. However, the minimum coupling attenuation that can be obtained with a reasonable directional characteristic is in the order of 10dB. On the other hand, it is virtually impossible, using microstrip technology, to design 3dB power dividers, such as are required when constructing push-pull mixers, or for feeding circular polarised antennas. It is possible, of course, when using tri-plate circuits for these values to be achieved, however, the conductor tracks are then so thin that it is hardly possible to use them in conjunction with higher power

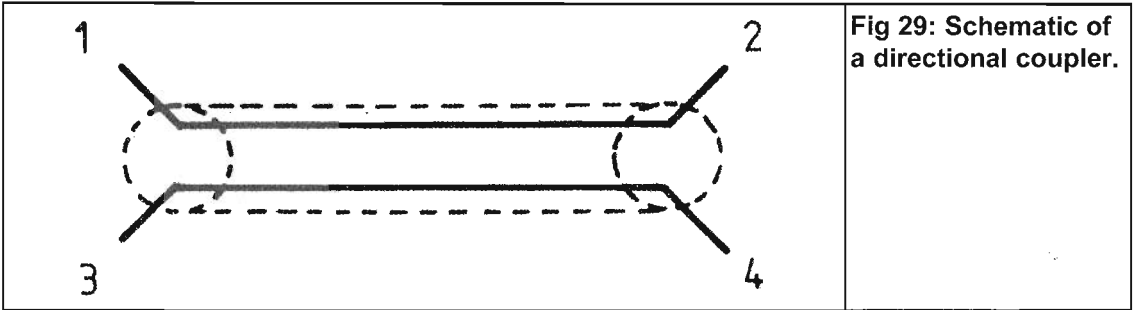

Fig 29: Schematic of a directional coupler.

levels. Most radio amateurs do not have the necessary machinery to construct conventional directional couplers mechanically, and do not have enough room for accommodating such large couplers.

A good solution for solving the problem of home made directional couplers is offered by a product manufactured by Sage Laboratories Inc. called "Wireline" and "Wirepac". It is possible using both these systems to construct directional couplers in the range of 3 to 20dB coupling attenuation in a frequency range from 50MHz to 2.4GHz. Wireline is the cheaper of the two and has a directivity of 20dB. Wirepac has a directivity of 30dB, but is considerably more expensive, and is therefore not to be discussed here.

Fundamentals

The Wireline type to be described is a line directional coupler and comprises two coupled lines as shown in Fig 29. The coupling attenuation is dependent on frequency and achieves its minimum value at a coupling length of $\lambda/4$ (see Fig 30).

Under matched conditions (Fig 31), the following is valid:

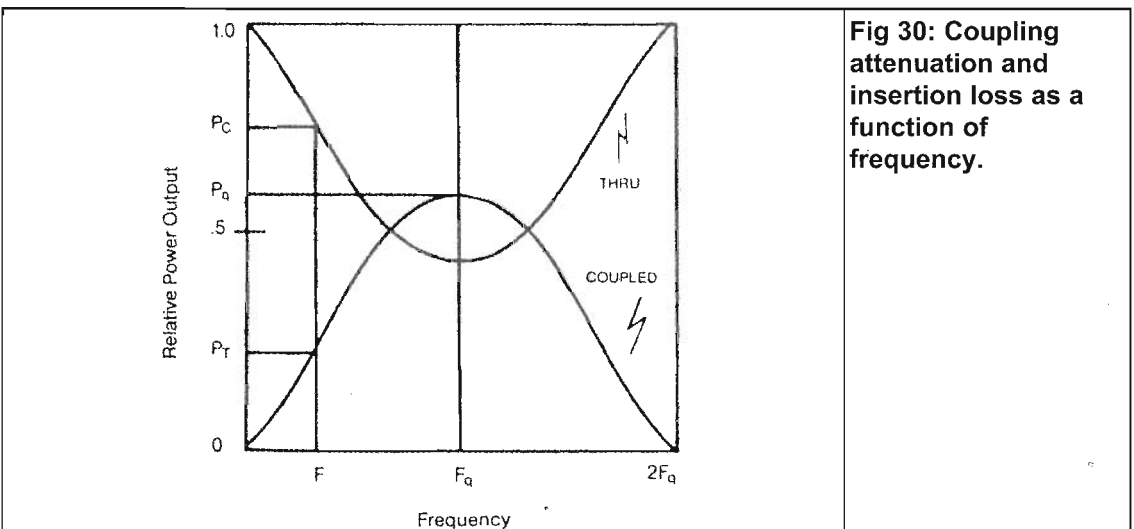

Fig 30: Coupling attenuation and insertion loss as a function of frequency.

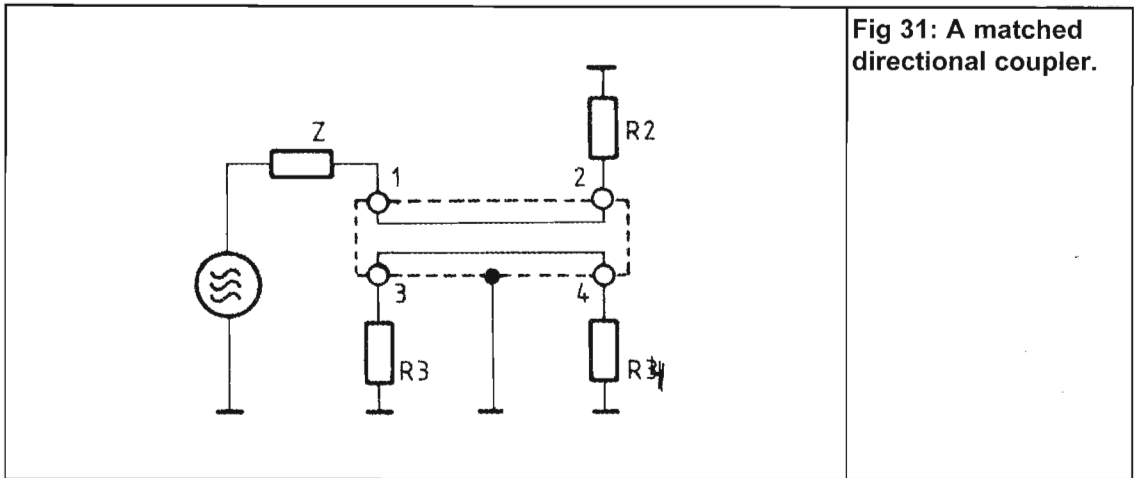

Fig 31: A matched directional coupler.

If a signal with a power P_1 is fed to the input, a power of $P_2 = P_1 - P_1 \times c$ will be present at R_2 , and a power of $P_3 = P_1 \times c$ at R_3 , where $c =$ coupling factor.

In the case of an ideal directional coupler, R_4 will be powerless, since the diagonally opposite inputs are decoupled from one another. In practice, a power will be present that is reduced to the value of the directivity d :

$$P_4 = P_1 \times c \times d (d = \text{directivity})$$

accordingly

$$P_3 = P_1 \times c - P_1 \times c \times d$$

A further characteristic of directional couplers is that the signals of the coupled outputs will have a frequency independent phase difference of 90° .

Construction of wireline

There are five different versions that differ in the type of screening and the maximum power ratings. The internal construction is shown in Fig 32. The following Table 1 shows the most important differences between the individual types.

Due to the coaxial type construction of the coupler, it is possible for the two coupled outputs to

Table 1: Wireline designs. P_m = mean power. P_p = peak value of power rating.

Type	H	HB	HC	JB	JC
Screen	Double foil	Copper mesh	Copper tube	Copper mesh	Copper tube
P_m/W	100	100	100	200	200
P_p/W	2000	2000	2000	2000	2000

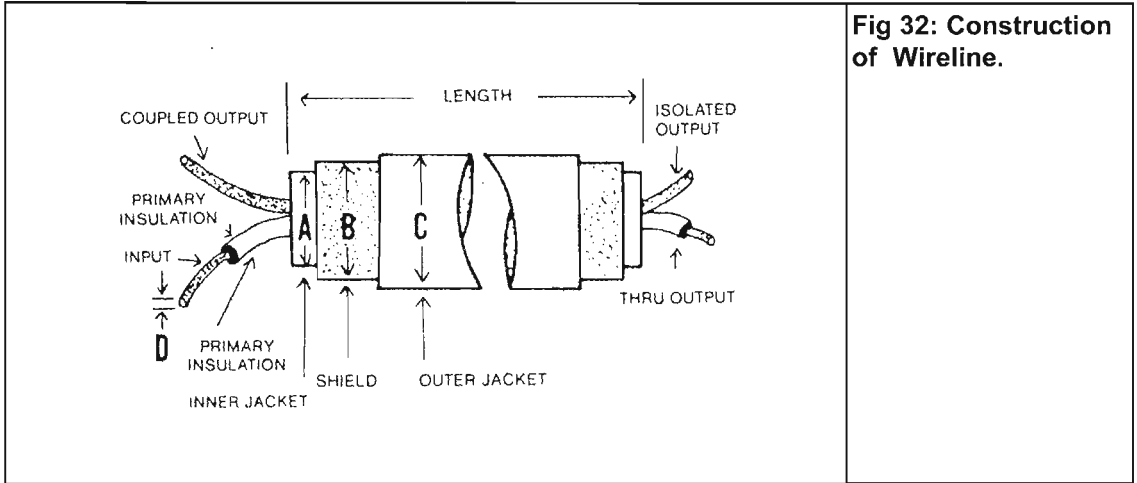

Fig 32: Construction of Wireline.

be provided on one side as shown in Fig 33. This offers several advantages for practical construction.

Calculation of the couplers

Calculation of a Coupler with a certain Coupling Attenuation at a certain Operating Frequency

The following data is required for the calculation:

- Required centre frequency f_{op} (e.g. 435MHz)
- Required coupling attenuation a_c (e.g. 10dB)

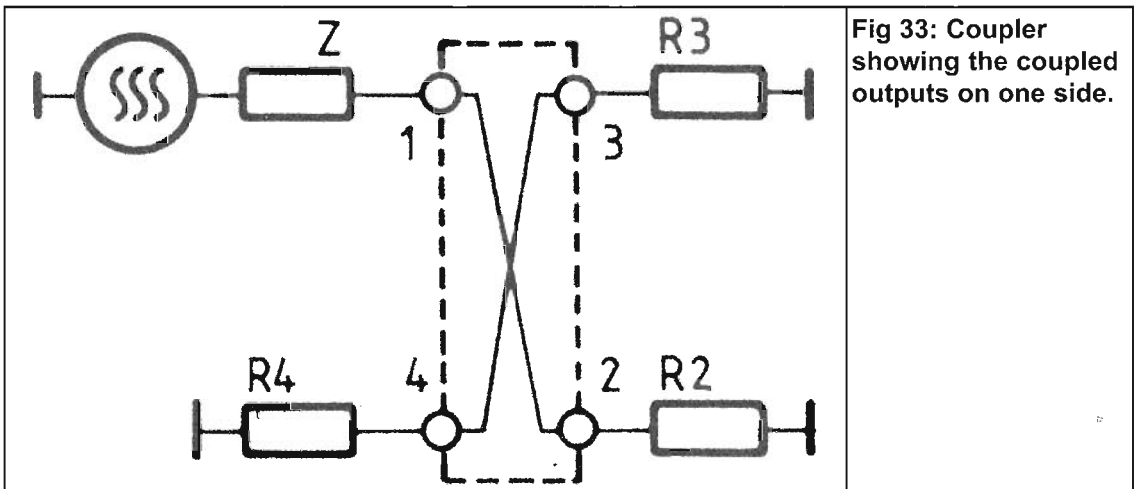

Fig 33: Coupler showing the coupled outputs on one side.

It is firstly necessary to convert the logarithmic value of the coupling attenuation a_c into the linear coupling factor c :

$$c = 10^{-\frac{a_c}{10}} \quad (1)$$

In the case of a 10dB coupler, the following results:

$$c_{10dB} = 10^{-\frac{10}{10}} = 10^{-1} = 0.1$$

Now the frequency at which 3dB coupling is achieved is calculated, using the operating frequency f_{op} and the coupling factor of the frequency f_c :

$$f_c = \frac{90 f_{op}}{\arcsin \sqrt{-\left(\frac{c}{c-1}\right)}} \quad (2)$$

The following will result using the values of $f_{op} = 435\text{MHz}$ and $c = 0.1$:

$$f_{c(10dB/435)} = \frac{90 \cdot 435 \text{MHz}}{\arcsin \sqrt{-\left(\frac{0.1}{0.1-1}\right)}} = 2010.66 \text{MHz}$$

From this quarter wave frequency (f_c) one then calculates the length l of the coupler as follows:

$$l = \frac{4700 \text{MHz} \cdot \text{cm}}{f_c (\text{MHz})} \quad (3)$$

This results in the following coupler length in our example:

$$l_{(10dB/435)} = \frac{4700 \text{cm}}{2010.66} = 2.338 \text{cm}$$

A 10dB coupler at 435MHz would therefore have a length of 23.38mm.

Calculation of the Coupling Attenuation of any required Coupler

The following data is required for calculation:

- Length (l) of the coupler in cm (e.g. 10cm)
- Frequency (f) at which the coupling attenuation is to be calculated (e.g. 435MHz)

Firstly find the quarter wave frequency (f_c) of the coupler:

$$f_c = \frac{4700 \text{MHz} \cdot \text{cm}}{l(\text{cm})}$$

Microwave Projects

In our example:

$$f_{c(10cm)} = \frac{4700MHz}{10} = 470MHz$$

This is followed by calculating the coupling factor c :

$$c = \frac{\sin^2\left(90 \frac{f}{f_c}\right)}{\sin^2\left(90 \frac{f}{f_c}\right) + 1} \quad (5)$$

In our example:

$$c_{(10cm435)} = \frac{\sin^2\left(90 \frac{435}{470}\right)}{\sin^2\left(90 \frac{435}{470}\right) + 1} = 0.4966$$

The coupling attenuation (a_c) is now calculated from the coupling factor:

$$a_c = -10 \log c \quad (6)$$

The following will result in our example:

$$a_{c(10cm435)} = -10 \log 0.4966 = -3.04dB$$

Practical applications of Wireline

Use as a Directional Coupler

Of course, the primary use of Wireline couplers is for determining the VSWR of antennas and other loads. The construction of VSWR bridges is not to be discussed, since it is well known.

Table 2: Directional coupler, length $l = 50mm$, coupling attenuation as a function of frequency.

f MHz	a_c dB	f MHz	a_c dB
3.5	44.66	28.0	26.61
7.0	38.64	145.0	12.64
14.0	32.62	435.0	5.13
21.0	29.10		

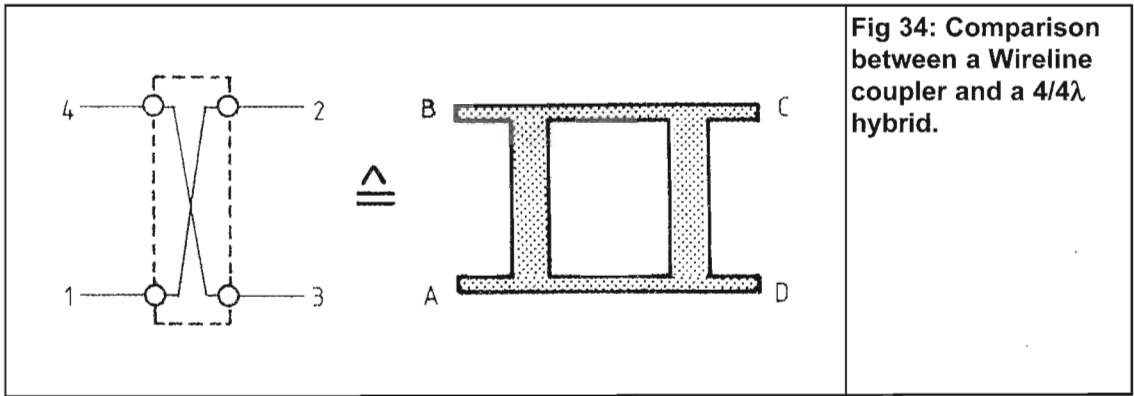

Fig 34: Comparison between a Wireline coupler and a $4/4\lambda$ hybrid.

Table 2, however, provides an aid for designing a directional coupler for frequencies up to 435MHz.

Use as a 3dB Coupler

This results in a multitude of applications of which the most important are to be mentioned.

Feeding of Circular Polarised Antennas

Since the coupled outputs always possess a phase shift of $90^\circ (\pm 1^\circ)$ to one another, it is easily possible to construct a low loss, wideband feed for circular polarised antennas (see Figure 35).

Directional couplers as shown in Figure 33 behave as a $4/4\lambda$ hybrid (see Figure 34). An RF voltage fed to 1, or A, will be distributed equally to 2 and 3, or C and D. Connection 4, or B, remains decoupled. A RF-voltage fed to 4, or B, will be distributed equally to 2 and 3, or C and D. In this case, 1, or A will remain decoupled.

Connections 2 and 3, or C and D, have a phase shift of 90° to one another (this will only be the case at the centre frequency of a $4/4\lambda$ hybrid).

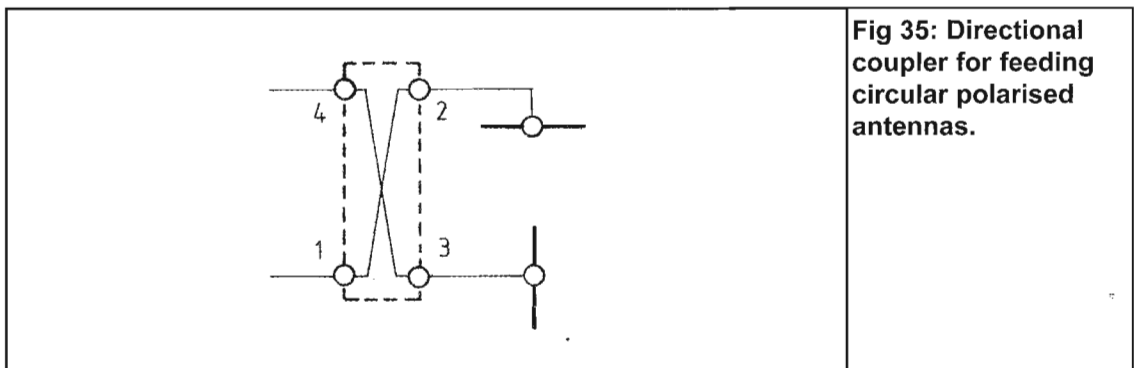

Fig 35: Directional coupler for feeding circular polarised antennas.

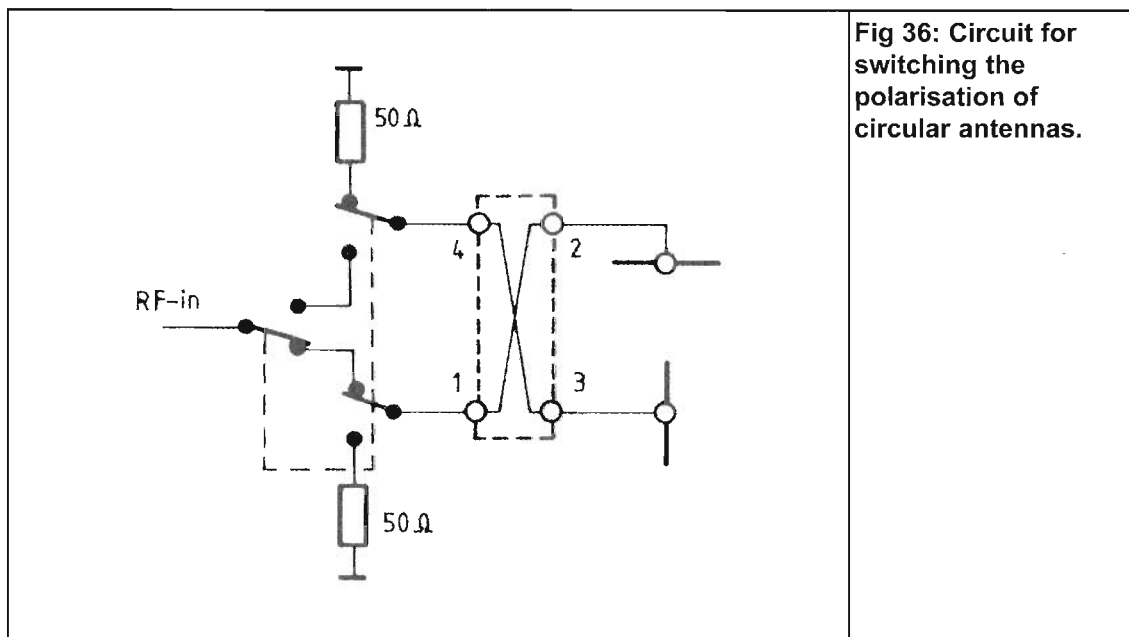

Fig 36: Circuit for switching the polarisation of circular antennas.

If, for instance, an RF signal is fed to 1, and 4 is terminated with 50Ω , anticlockwise, circular polarisation will result. If, on the other hand, 4 is fed with the RF voltage, and 1 is terminated with 50Ω , clockwise, circular polarisation will result. Of course, the actual polarisation will also be determined by the phase position of the individual antenna. An anticlockwise circular polarisation will be changed to clockwise polarisation on rotating the phase position of one of the antennas by 180° .

As can be seen, the polarisation switching is nowhere near as critical as when using conventional coaxial delay line methods, and where the switching relay must be taken into consideration in the phase shift calculation. In the case of the described type of feeding, the relay is placed in front of the phase shift 3dB coupler (Figure 36). Attention must only be paid to ensure that the lengths of the antenna feeders are identical. The terminating resistors should have a rating of one 100th of the transmit power if the antenna matching is good.

Construction of Push-Pull Mixers

A further application of Wireline 3dB couplers is given in the construction of push-pull mixers (Figure 37). A mixer constructed in this manner will have a bandwidth of one octave (frequency ratio 1:2).

Construction of Wideband Power Amplifiers

At higher frequencies, it is difficult to connect wideband amplifiers in parallel to achieve higher power levels. In most cases, $4/4\lambda$ hybrids are used. This means that it is possible to use

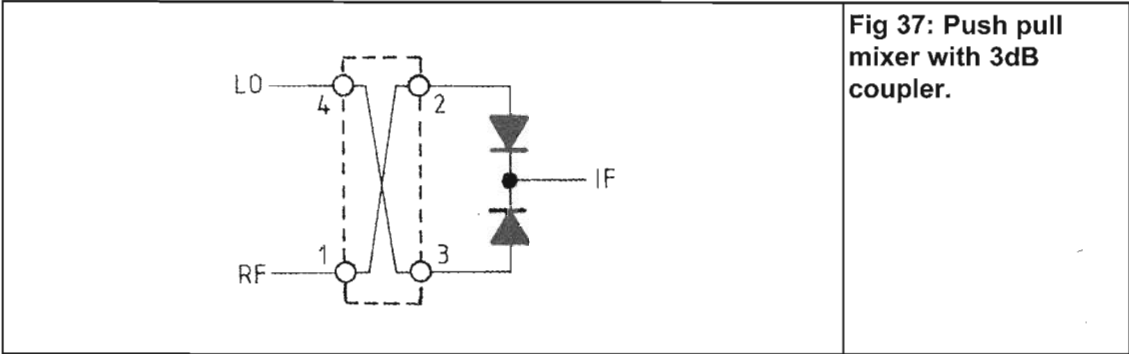

Wireline 3dB couplers here, which also have the advantage of being much smaller (Figure 38).

Manufacturer availability of Wireline and design programs

Wireline is available from Sage Laboratories Inc:

11 Huron Drive
Natick, MA 01760-1338
Phone: (508) 653-0844
FAX: (508) 653-5671
e-mail: info@sagelabs.com
web site at: www.sagelabs.com

There is a full description of Wireline and its uses on the sage page:

<http://www.sagelabs.com/components/wireline.html>

and a useful Wireline calculator is available from:

http://www.rfcafe.com/business/software/wireline/wireline_calc.htm

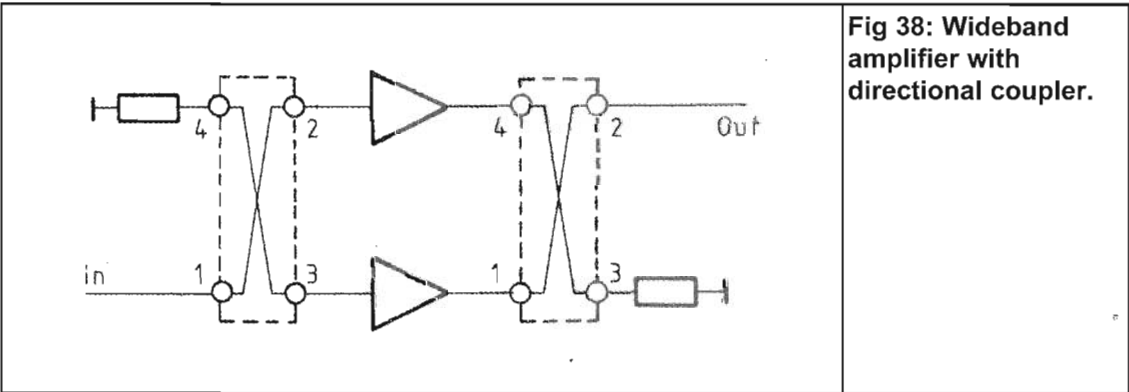

Table 3: Coupling length as a function of coupling attenuation and frequency.

f MHz	3dB	6dB	10dB	20dB
3.5	too long	too long	too long	860mm
7.0	too long	too long	too long	430mm
14.0	too long	too long	726mm	215mm
21.0	too long	880mm	484mm	143mm
28.0	too long	660mm	363mm	107.5mm
145.0	324mm	127.5mm	70.1mm	20.7mm
435.0	108mm	42.5mm	23.4mm	too short
1275.0	36.9mm	too short	too short	too short
2350.0	20.0mm	too short	too short	too short

A new 10GHz Divide-by-10 Prescaler, Grant Hodgson, G8UBN

This prescaler is the first of a series of new designs by Grant Hodgson using state-of-the-art components. The PCB for this design is available from GH Engineering [15]. The construction techniques required to mount the SMD ICs need special equipment but Grant plans to make partially completed kits available.

Introduction

A prescaler is a digital frequency divider; the output signal is simply the input signal divided by an integer (i.e. a whole number). Prescalers are digital devices and therefore the amplitude of the output bears no resemblance to the input.

Prescalers have two main functions for amateur microwave use:

- To extend the range of frequency counters
- Dividing the output of a Voltage Controlled Oscillator when used in a frequency synthesiser.

This article will concentrate on the former application, although the same design can be used in the latter application as well.

Digital Prescalers

Dividing the frequency of a signal by two is very easy; all that is required is a single D-type flip-flop, or latch, with the input signal being connected to the clock pin and the Q output being connected to the D input as shown in Fig 39. The output signal is usually taken from the Q output.

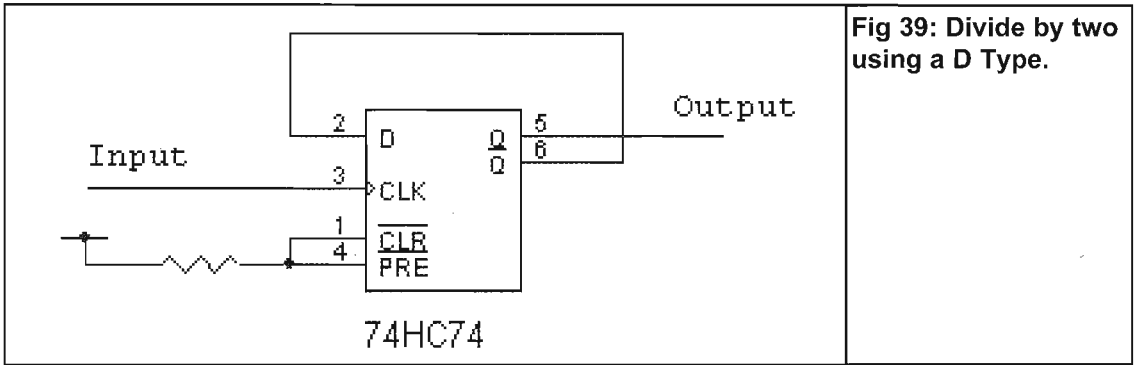

Fig 39: Divide by two using a D Type.

Cascading prescalers (i.e. connecting them in series) is also easy; in this way it is possible to generate division ratios of 4,8,16 etc; division by 64 and 256 is very common. Prescalers operating at microwave frequencies are now commonplace; semiconductor manufacturers such as Fujitsu and Hittite have been making divide by 8 prescalers that can be used with input frequencies exceeding 10GHz for several years.

Low cost frequency counters are now readily available that will operate at frequencies up to 1GHz or even 3GHz, the quality varies somewhat and generally speaking, you get what you pay for. However, microwave counters operating up to 10GHz or above are very expensive, even on the second-hand market, and are often difficult to find at all.

By combining a divide by 8 prescaler with a frequency counter operating up to (say) 1.5GHz, it is possible to measure the frequency of a 10GHz signal, and possibly being usable to 12GHz. However, in order to determine the exact frequency of the device under test it is necessary to multiply the reading on the frequency counter by 8 - not too difficult if the counter reads 1.1101, but multiplying a number such as 1.2778563 is a little more complicated, usually requiring a calculator.

New Divide by 10 prescaler

Thanks to some recent advances in high-speed digital electronics, the problem of multiplying the displayed frequency on the counter by a factor of 8 has been solved. Hittite Microwave Corporation[16] has recently (October 2002) released a revolutionary divide by 5 prescaler IC. This remarkable little IC requires only a single 5V supply and a couple of external capacitors to operate; the input frequency extends from DC to 7GHz. The internal circuitry of a divide by 5 prescaler is a trivial task when working at low frequencies using standard CMOS techniques. When working at microwave frequencies the number of individual transistors required to form the appropriate circuitry poses a number of technical problems, and the availability of the HMC438 marks a significant breakthrough [17].

Hittite also make a divide by 2 prescaler which operates from DC to 11GHz; cascading these devices results in a true divide by 10 prescaler that can be used up to at least 10GHz and beyond.

The full circuit diagram is shown in figure 40.

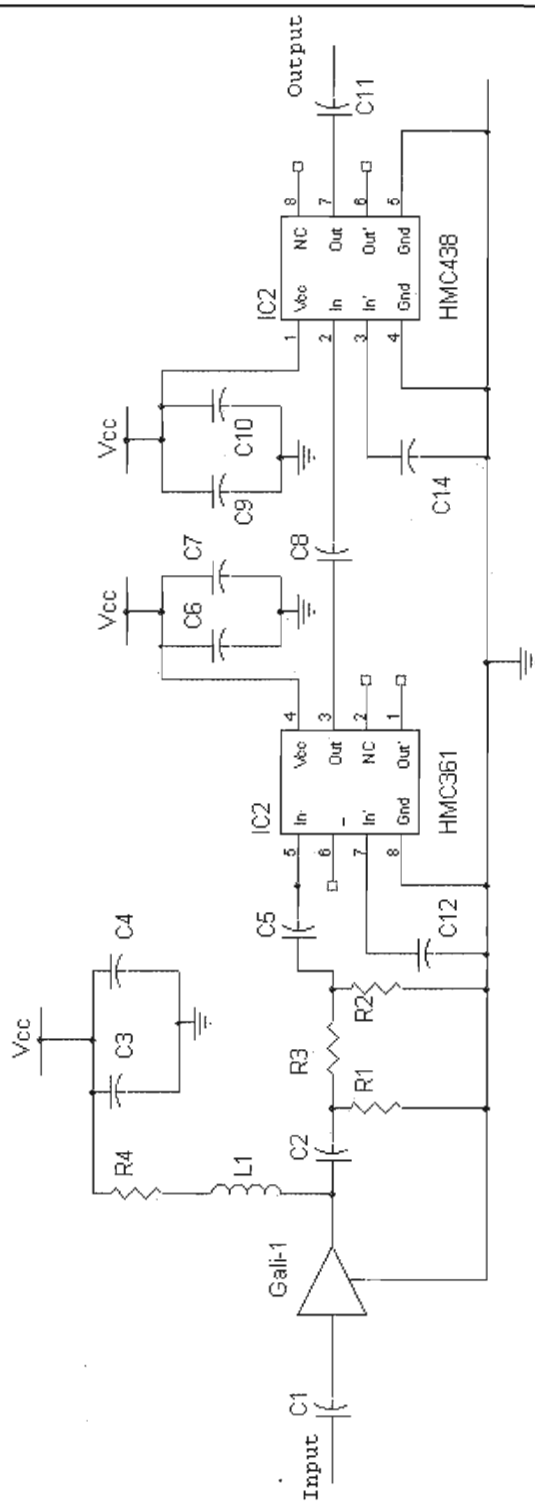

Fig 40: Circuit diagram of 10GHz divide by ten prescaler.

The input signal is DC blocked by the capacitor C1. The value of this capacitor determines the sensitivity at both high and low input frequencies. Due to the fact that the prescaler is intended for high frequency operation, the value of the capacitor has been chosen to maximise the input sensitivity at higher frequencies.

The input signal is amplified by IC1. This is a Gali-2 MMIC (Monolithic Microwave Integrated Circuit) from Mini-circuits. The amplifier is driven into saturation, which ensures that the output level is constant. IC2 also provides a secondary function in the form of an input protection buffer; if an excessively large input signal is applied IC1 will be damaged, but this is much easier and cheaper to replace than IC2.

The level of the signal is then attenuated by the Pi-attenuator R1-R3. The signal level at the output of the attenuator is at a level of approximately -2dBm, close to the optimum level for the first prescaler. IC2 is the first prescaler, an HMC361. This divides the signal by a factor of 2. The HMC361 has two balanced inputs; the attenuated signal from IC1 is connected to one input (pin 5) and the other input is connected to ground via the capacitor C12. The HMC361 also has two complementary outputs; again only one of which is used the other is simply left open circuit. The divide-by 2 output at pin 3 is DC blocked and connected to one of the inputs of IC3, an HMC438 divide by 5 prescaler. As with IC2, there is an unused input, this is grounded by a capacitor and the unused output is left open circuit. The output of IC3 is pin 7, this is DC blocked by C11; this output signal is exactly 1/10th of the input frequency and can be connected to any suitable frequency counter.

IC1-3 are connected to a single +5V supply; both prescaler ICs have two decoupling capacitors placed close to the VCC supply pins. L1 is a Mini-Circuits ADCH-80A broadband choke that provides high inductance from 50MHz to 10GHz. R4 sets the current through IC1 to 25mA.

Construction

A PCB has been made for this project for those that feel confident to be able to solder the small devices. The PCB has provision for all the components including a 5V regulator and SMA 'end-launch' sockets for the input and output. The PCB also has provision for a number of other features that will be briefly described later.

The biggest problem when trying to build this particular project is soldering the prescaler ICs, and in particular the HMC438 which is very small indeed. Both the HMC361S8G and the HMC438 have a ground 'slug' on the underside of the package that cannot be seen when the IC has been soldered. The intention of the IC manufacturers is that these components are soldered using commercial SMD re-flow techniques whereby solder is applied automatically in paste form, and melted in a special oven. These techniques are not suitable for small production runs, and the equipment required costs about as much as a small house. However, it is possible for advanced constructors to solder these devices at home, although some experience with small surface mounted components is required, as is some form of optical aid, a heat gun and some solder paste.

For best results the prescaler ICs are soldered first, one at a time. The technique involves placing a small amount of solder paste on the central ground pad on the PCB, and either

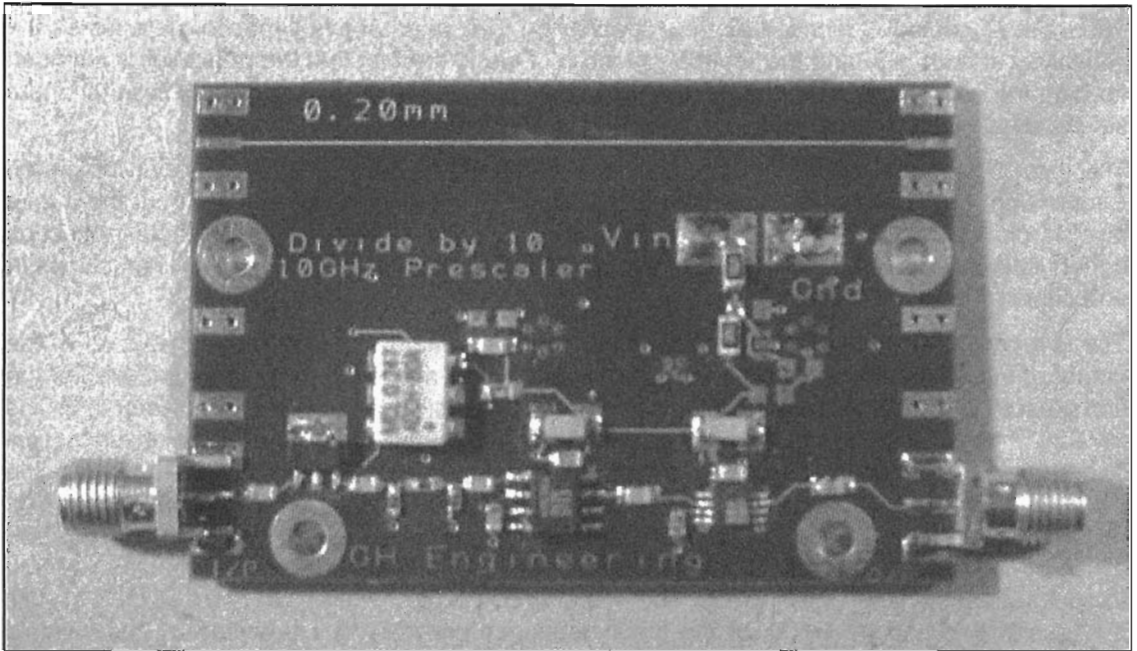

Fig 41: Photograph of the 10GHz divide by ten prescaler.

applying a small amount of solder on each of the PCB pads for the IC pins, or applying the solder paste in a long line for pins 1-4 and 5-8. The prescaler IC is then very carefully placed onto the PCB, taking care to note the correct orientation. The IC will sit on top of the solder paste, and it helps if it is pushed down very slightly without twisting or moving it. The solder paste is then melted using a heat gun; the most suitable tool is a small, high wattage (> 1000W) gun used for heatshrink tubing with a small nozzle. Extreme care must be taken to ensure that the correct amount of heat is applied - too little heat and the solder paste will not have melted, which can lead to small solder balls which in turn can cause short circuits. Too much heat will damage the PCB and/or the IC. The right amount of heat will melt the solder paste properly, simultaneously soldering all 8 pins and the ground slug. As the heat is applied, several things happen :-

- The solvents in the solder paste evaporate and the flux becomes active.
- The solder on the pads for the IC pins melts. As this happens, the surface tension of the liquid solder pulls the IC on each of the 8 pins. If the solder on all 8 pins melts at approximately the same time, the IC will automatically be pulled to the exact centre of the pads - even if it was placed with a slight offset. The effect of this has to be seen to be believed - it really does look like magic, but is really just the application of physics!
- As the solder melts, it naturally flows onto the exposed, tinned pads on the PCB, and so any paste that has been applied onto the areas covered by solder resist (the green coating on the PCB) will tend to flow towards the nearest exposed pad, thus automatically reducing the chances of a short circuit between adjacent pins.

Table 4: Parts list for 10GHz prescaler.

C1,2,5,12	4.7pF	R1,2	220Ω
C3,11	100pF	R3	22Ω
C4,6,9	10nF		
C7,10	10μF Tant	IC1	Gali-1
C8,14	10pF	IC2	HMC361S8G
		IC3	HMC438

- At this point, the solder paste on the underside of the ground slug has not fully melted. It is necessary to keep the heat applied to the IC whilst the solder on the outer pins is still molten.
- Then the IC will move slightly downwards as the solder under the IC melts and the surface tension pulls the IC further down onto the PCB. This is a very subtle effect, but can be seen with some experience and especially with good optical aid such as a microscope.
- At this point the heat is removed and the board is left to cool, and then the solder paste for the other prescaler can be applied and soldered as above.

There has been some considerable debate on the US Microwave reflector [18] recently about alternative methods of soldering devices such as the Hittite prescalers with the 'hidden' ground slug; alternatives to the use of a heat gun are to place the PCB on a hotplate at a temperature considerably greater than the melting point of solder, or to use a conductive epoxy to mount the prescaler ICs. The hotplate method is currently being investigated by the author. The use of epoxy would be an option, but unlike solder paste is very difficult to obtain in very small (i.e. cost-effective) quantities, and requires special care when curing, so it is felt that the use of solder paste would be the best option for home construction.

Note that the HMC438 is considerably smaller than the HMC361S8G - the HMC438 has pins on a pitch of only 0.65mm - that is the distance between the centre of the pins, not the gap between them! Although very small, this is an industry standard package, and is widely used for many ICs - especially microwave ICs. The use of good optical aid is mandatory; there has been discussion of this recently both on the US microwave reflector and in Technical Topics in The RSGB Radcom.

Some of the RF coupling and de-coupling devices are also very small, being of 0603 size - i.e. 1.5mm long x 0.75mm wide. These components can be soldered with a soldering iron with a small tip, fine solder (preferably 30SWG, although 26SWG can be used), optical aid and of course a steady hand! The reason for using such small capacitors is that they have a much lower self-inductance, and therefore a higher self-resonant frequency. This means that higher values of capacitor can be used (4p7) for the high frequency part of the circuit, which increases the sensitivity at lower frequencies such as 4GHz. Therefore, smaller capacitors have the effect of increasing the effective frequency range over which the prescaler can be operated.

It is fully appreciated that some microwave constructors will feel somewhat nervous about performing such delicate soldering techniques on tiny, expensive devices. For this reason the

Microwave Projects

author is considering the option of making the PCB available with the ICs already soldered and tested, and possibly some of the other small surface mounted devices mounted as well. This would give a 'half-way house' whereby the hardest part of the construction has already been done, but the easier parts such as soldering the connectors and IC1, and mounting in a case would still be done by the constructor.

Printed Circuit Board

The PCB for this project requires special mention. It is made from 1.6mm FR4 (fibreglass), but instead of having the components on one side and a groundplane on the other, the PCB has 4 layers, with 2 groundplanes sandwiched in the middle of the board. The reverse side of the PCB is thus free for extra circuitry, and has been used as a 'Microwave Experimenter's Project Board' which consists of pads for two Mini-Circuits Gali-MMICs, a passive, broadband frequency doubler, a SPST RF solid state switch and the possibility of a second frequency doubler.

The use of a 4-layer PCB is believed to be unique in amateur microwaves. It has the advantage that although the RF properties of FR4 are inferior to Duroid and equivalents, the groundplanes are only 0.3mm below the surface layers, which may allow the use of this type of board at 24GHz. Of course the losses in the FR4 will preclude the use of this type of PCB for LNAs and PAs at such frequencies, but for other purposes such as doublers, mixers, filters and driver/buffer amplifiers this new 4-layer PCB technology may be usable at a much lower cost than Duroid, and can be manufactured commercially with plated through holes (vais) in very small quantities. Any losses can easily be overcome with new high-frequency MMICs (such as the Galis), (at 10GHz or 12GHz) and 1.6mm FR4 is considerably stronger than 0.25mm (or similar) PTFE material.

Performance

The maximum input frequency at which the prescaler will work is determined by a number of factors, including:

- The gain of IC1
- The loss associated with L1
- The reactance of C1, C2 and C5 at frequencies above 10GHz
- The upper frequency limit of IC1

In practice, the prescaler has been found to have an upper frequency limit of around 14GHz at an input level of +13dBm.

IC2 has a specified maximum frequency of 11GHz, so this extra performance should be considered a bonus and cannot be guaranteed. For use at 10.4GHz, the minimum input level is approximately -15dBm. The maximum input level is 15dBm, this is the absolute maximum input

power for the Gali-2 MMIC. The prescaler has a definite cut-off point; when the input signal is even very slightly above the maximum operating frequency the prescaler simply stops working and the output becomes unstable. Therefore it is very evident whether or not the prescaler is working properly. Note that this is usually not the case with a frequency counter, where the counter usually starts to display a frequency slightly less than the true input signal. Also note that when no signal is present at the prescaler input, the prescaler becomes highly unstable and oscillates. However, unlike the Fujitsu divide by 8 prescaler (which oscillates at a fairly constant frequency with no input signal), the Hittite prescalers display a number of spectral lines that cannot be resolved by a frequency counter. This instability is to be expected, and is probably caused by the positive feedback action of the input circuitry trying to capture the input (sine wave) signal. With no input signal present, the input circuitry of the prescaler is trying to capture noise and becomes unstable. However, as soon as an input signal of sufficient level is present, all signs of instability disappear and the prescaler behaves normally. The DC current drawn by the prescaler does not increase in the unstable (no input signal) state.

Options

It is fully appreciated that this is not a cheap project, although it is felt to give reasonable value for money considering the high performance and the use of the newest prescaler technology. For those that want a 10GHz prescaler at a lower cost, IC2 can be replaced with an HMC363S8G divide by 8 prescaler IC, IC3 and associated components are not fitted and the output from IC2 routed directly to the output socket.

For an even higher frequency prescaler, IC2 can be replaced with an HMC364S8G which is a divide by 2 prescaler identical to the HMC361S8G, but with an upper frequency limit of at least 13GHz, and may be useable well beyond that, although this has not yet been tested.

For more sensitivity at 10 or 12GHz, IC1 could be replaced with a Gali-19 high frequency MMIC; the author is currently testing this option.

References

- [1] O. Frosinn, DF7QF: A Home Made UHF/SHF Power Meter, VHF Communications, 4/1981, Pages 221-229
- [2] A. Kraus: Einführung in die Hochfrequenz-Meßtechnik Pflaum-Verlag München 1980, Pages 219-227
- [3] A. Hock, u. a. Hochfrequenz-Meßtechnik Part 1 Volume 31a, Kontakt & Studium Expert Verlag, Grafenau 1981, Pages 121-129
- [4] VHF-UHF Manual 3rd Edition, Chapter 10
- [5] Marconi Instruments Catalogue of Microwave Instruments, Components and Waveguides 1981/82

Microwave Projects

- [6] Siemens Matsushita Components, <http://www.siemens.de/pr/index.htm> or EPCOS UK Ltd, <http://www.epcos.com>. An enquiry to Siemens via their web site in January 2003 got the following reply from a product marketing engineer at EPCOS "The K19 is a fairly old design with some versions still available, I recommended the G540 type for any new designs"
- [7] C. G. Lodstrom, Transistoriserad Resonansmeter; Radio & television (Sweden) 3/1975 pp. 23-24
- [8] N. Rohde, EMC and its Consequences; VHF Communications 3/93 pp. 185-187
- [9] Ultralife U9VL-BP, 10 year guaranteed storage life. Ultralife Batteries, Inc., P.O.B 622, Newark NY 14513; or from the author at US \$ 6.50 each. Postage may have to be added, they weigh 40g each in "bubble-pack"
- [10] D. Burchard, Shortwave Reception Based on the Thirties' Principles, VHF Communications 1/90 pp. 23-30 and 2/90 pp. 70-76
- [11] Measurements on resonance in capacitors, Carl Lodstrom, SM6MOM/W6, VHF Communications 4/1994 pp 249 - 253
- [12] Dr.-Ing. J. Jirmann und Michael Kuhne: Measurement aids for the UHF amateur, VHF Reports 1/93, Verlag UKW-Berichte, Baiersdorf
- [13] Data sheet SP8910, Zarlink
- [14] Data sheet ERA-1, Mini-Circuits, www.mini-circuits.com
- [15] GH Engineering, The Forge, West End, Sherborne St John, Hants, RG24 9LE, UK, Tel +44 (0)1256 889295, Fax +44 (0)1256 889294. Email: sales@ghengineering.co.uk and Web: www.ghengineering.co.uk
- [16] www.hittite.com, data sheets for HMC361S8G and HMC435
- [17] New 12Ghz prescaler using Hittite HMC363S8G, David Wrigley, G6GXX, www.microwave.fsnet.co.uk/projects/projects-1.htm, and CQ-TV 185, British Amateur Television Club
- [18] www.wa1mba.org/reflect.htm

Microwave Design

In this chapter :

- Modern design of band pass filters made from coupled lines
- Using TRL85 for synthesis and analysis of microwave problems

One of the things that deters amateurs from constructing microwave equipment is that at times it seems to be a black art. At lower frequencies the physical layout of a circuit has less influence on performance and components such as capacitors and inductors can be recognised. Microwave circuits are more complex and until recently design was not easy. There are now many CAD packages available to assist with the design and implementation of microwave circuits. This chapter contains some articles that introduce how to use some of these products using worked examples. Even if you do not intend to design microwave circuits, an understanding of how they are designed will help when a kit or ready built circuit does not work as expected and needs “tweaking”.

Modern design of band pass filters made from coupled lines, Gunthard Kraus, DG8GB

Nowadays there are many aids available to any electronics developer. Even for development work in the area of high frequency engineering, there is some very powerful software in existence, some of which is available without charge on the Internet. The use of modern design and simulation tools is described below by means of examples.

Introduction

Some years have passed since the series of articles entitled “Design and realisation of microwave circuits” in [1], where this subject was dealt with comprehensively. In the intervening period, the options for finding information and for circuit simulation have multiplied greatly. In addition, the analysis options are more precise, thanks to continuous improvements in the CAD field.

A “test version” or “student version” of almost any modern CAD or simulation programs can now be obtained from the Internet, including the original manuals. These are usually complete textbooks in themselves - and mountains of application notes on almost any subject. The real

Microwave Projects

problem becomes how to make a suitable choice. “Know-where and know-how” are also important, because all test versions of what are usually very expensive programs have some kind of limitations. And there's nothing more irritating than to slog away familiarising yourself with a new program and then suddenly realising that the program available just can't go any further with the problem you're working on.

So the idea here is to demonstrate the correct and successful design of stripline band-pass filters, together with their implementation in practice. We shall compare not only the procedures but also the degrees of success, using the tried and tested CAD program “PUFF” (Version 2.1) and the ultra-modern student version of ANSOFT Serenade.

A glance at the technology

Band pass filters serve to separate out a specific frequency range, while simultaneously suppressing, as far as possible, all undesirable signals outside this range. The following filter models can be considered for the microwave range in this context:

- Waveguide filters (for very high power levels)
- Coaxial filters
- Helix filters
- Filters made from ceramic resonators
- SAW filters
- Inter-digital band-pass filters
- Stripline filters with coplanar structures
- Microstrip filters made from coupled lines
- Hairpin filters, etc.

If we also lay down additional requirements, such as:

- DIY manufacture as simple printed circuit board at lowest possible cost
- easily convertible to other frequencies without high costs or problems
- no smoothing
- absolute reproducibility

then the two last types are usually given preference. In this context, hairpin filters represent a modified version of the standard stripline filter for shortening the construction length and increasing the edge sharpness. The disadvantages of larger dimensions must be taken into account.

Principles of stripline band pass filters made from coupled lines

We are using "coupled lines", i.e. two striplines which are running in parallel and close together. Due to running closely together in parallel, we obtain not only a capacitive coupling (via the electrical field) from one line to the other, but also a magnetic coupling. The magnetic field of one line induces an electrical voltage in the second line and thus transfers electrical power. The remarkable thing here is that the different waves triggered through this coupling from one line onto the other are added together in one direction only. But in the other direction they are in anti-phase and try to cancel each other.

This is precisely the behaviour of a directional coupler and it is also the main applications area for this line structure. This behaviour can be used to separate forward and return waves in a system!

However, the description of such a component for simulation can be expanded further, Due to the fact that some of the waves triggered in the second line are in-phase and some are anti-phase, it is necessary to specify two different impedance levels, namely

- the EVEN impedance (or: in-phase impedance)
- the ODD impedance (or: anti-phase impedance)

The EVEN impedance level is always higher than the system impedance (usually 50Ω), whereas the ODD impedance is essentially lower than the system impedance used.

The relationship of the three impedance levels to one another always depends on the formula:

$$Z^2 = Z_{EVEN} \cdot Z_{ODD}$$

Note:

As soon as one impedance is specified, many CAD programs react in the following way. If the impedance exceeds the system impedance, Z, then it is indicated as the EVEN impedance, and the missing ODD value is calculated in accordance with the above formula - and vice versa.

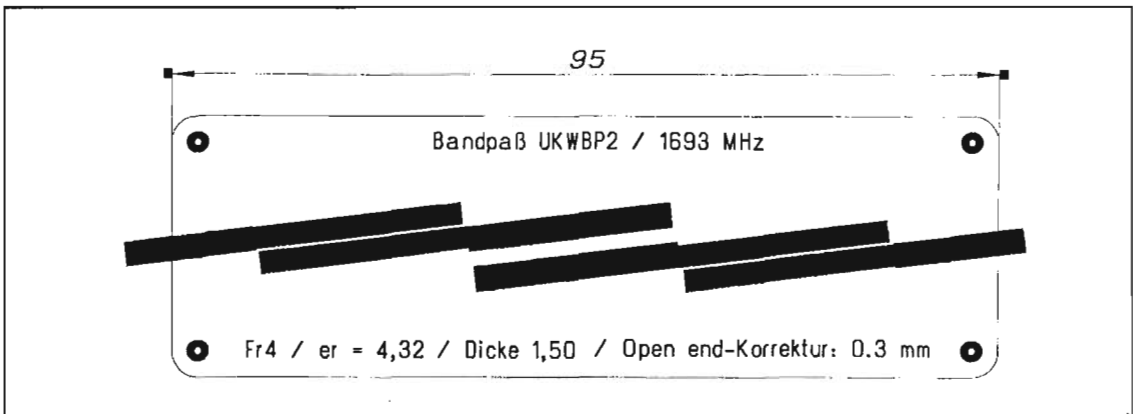

Fig 1: PCB layout for a 1693MHz band pass filter.

Microwave Projects

Now for stripline band-pass filters

If several such coupled line pairs, with 90 degree electrical length, are connected together in series, the line sections act as resonators and the input signal is transmitted from input to output, only in the range around this frequency. Thus the desired band-pass behaviour is obtained. Unfortunately, this is repeated at the odd multiples, i.e. for example the triple frequency, etc.

For the practical implementation, see Fig. 1.

It can be seen that, in addition to the three coupled line pairs, the 50Ω striplines are also used as connection to the SMA sockets. The underside of the printed circuit board is a continuous earth surface.

The design technique: from the standard low pass to the stripline band pass filter

Preliminary work

The circuit developer is initially faced with the following decisions:

Which type of filter is the correct one? The choice will be, for example, Bessel, Butterworth, or Chebyshev filters:

- Chebyshev filters display ripple in the pass band range, but as against that they can offer good edge sharpness for the transition into the filter stop band.
- If, in contrast, we need better group delay behaviour and no ripple in the transmission range, we go for Butterworth filters, though their edge sharpness in the filter stop band is markedly lower than that of the Chebyshev type.
- If the filter has to remain as gentle and as smooth as possible at all points, that leaves only the Bessel filter. Mind you, we pay for this “gentle” behaviour with a very “tired” transition from the pass band to the stop band (in order to keep phase distortion as low as possible). Thus, there is scarcely any edge sharpness to speak of in the filter stop band.

Then comes the question of the degree of filtration, N , which for normal low pass filters directly corresponds to the number of components needed. A greater degree of filtration brings about sharper edges in the filter stop band, but in practise the attenuation in the pass band is also increased, due to the greater number of components and their losses.

In practice, the type of filter used very frequently is the Chebyshev, with N between 3 and 5. For this reason, a filter from this group is taken as an example here.

The next decision relates to the system impedance (usually 50Ω). Moreover, especially for Chebyshev filters, the maximum pass band ripple, the reflection factor, etc, must be determined.

It should be borne in mind that the variables:

- Pass band ripple (oscillations of S21 and / or the transmission loss)
- reflection factor r
- voltage standing wave ratio VSWR
- S11
- reflection attenuation a_r

are inseparably associated with each other in the Chebyshev type! The following relationships apply:

- Between the reflection factor r and the voltage standing wave ratio VSWR:

$$r = \frac{VSWR - 1}{VSWR + 1}$$

- Between the reflection factor r and the pass band ripple (maximum transmission loss in dB)

$$a_{MAX} = 10 \cdot \log \frac{1}{1 - |r|^2}$$

- Between S11 and / or S22, the reflection factor r and the reflection attenuation a_r

With correct matching, S11 and / or S22 correspond precisely to the reflection factor of the filter, but are normally specified in dB:

$$S11 = S22 = 20 \cdot \log |r|$$

The reflection attenuation is then simply the “negative dB value of S11 or S22”! Correctly:

$$a_r = 20 \cdot \log \frac{1}{|r|}$$

The following summary table (drawn up in accordance with the above formula) is intended to serve as a small design aid:

Reflection factor r	Reflection attenuation a_r	S11 or S12	Chebyshev ripple of transmission loss
50%	6dB	6dB	1.25dB
20%	14dB	14dB	0.177dB
10%	20dB	-20dB	0.436dB
5%	26dB	-26dB	0.01dB
2%	34dB	-34dB	0.0017dB
1%	40dB	-40dB	0.00043dB
0.5%	46dB	-46dB	0.0001dB

(In practise, a maximum reflection factor between 5 and 10 % is usually sufficient...)

Microwave Projects

Designing a GPS bandpass filter

A bandpass for GPS with the following data is intended to serve as a design example:

Filter type:	Chebyshev
Mean frequency	$f_0 = 1575\text{MHz}$
Lower limiting frequency	$f_{\min} = 1550\text{MHz}$ as ripple limiting frequency
Upper limiting frequency	$f_{\max} = 1600\text{MHz}$ as ripple limiting frequency
Degree of filtration	$N = 3$
System impedance	$Z = 50\Omega$
Max. reflection factor	$ r = 10\%$
Max. ripple	$a_{\max} = 0.0436\text{dB}$
Reflection attenuation in pass band:	$a_r = 20\text{dB}$
S11 in pass band, if at all possible less than	$S_{11} = -20\text{dB}$

The selected reflection factor $r = 10\%$ gives a maximum ripple of 0.0436dB in the pass band.

This means that S21 can fall as low as -0.0436dB, whilst S11 and S22 never exceed 20dB.

Note:

The following calculation technique is taken from the book, Microwave Engineering by David Pozar [5], Page 484.

Additional note:

The degree of filtration, N, should always be selected to be odd (i.e. 3, 5, 7...), because the source resistance and the load resistance is identical under these conditions. Apart from this, make sure that the number of coupled line pairs is always 1 more than the selected degree of filtration. For $N=3$, there must thus be four line pairs.

And now to the individual design steps:

1st step:

First we need the filter coefficients of a single low-pass filter for this case. For this we can, for example, use the "faisyn" program (obtainable, for example, from <http://www.rfglobalnet.com>).

The above filter data are entered in succession when the program makes the corresponding requests, and the option "Parallel Capacitor" is selected. Thus the following table is finally obtained, with the 4 coefficients required for the calculation (Fig. 2):

$$\begin{aligned}g_1 &= \text{cap1} = 0.8532 \\g_2 &= \text{Ind1} = 1.1038 \\g_3 &= g_1 = \text{cap2} = 0.8532 \\g_4 &= \text{normalised load resistance} = 1.00\end{aligned}$$

2nd step:

Specification of fractional bandwidth of pass band:

$$\Delta = \frac{f_{\max} - f_{\min}}{f_{\text{mean}}} = \frac{1600 - 1550}{1575} = \frac{50}{1575} = 0.031746$$

```

Normalized Lowpass Prototype Filter Components:
Wc=1 rad/sec, Normalized Source Resistance=1
CAP 1 0 C= 0.8532
IND 1 2 L= 1.1038
CAP 2 0 C= 0.8532
The Normalized Load Resistance= 1
Press any key to continue...
    
```

Fig 2: Filter coefficients from Faisyn.

3rd step:

Now we come to the admittance inverter constants for the four line pairs:

1st line pair:

$$Z_0 \cdot J_1 = \sqrt{\frac{\pi \cdot \Delta}{2 \cdot g_1}} = \sqrt{\frac{\pi \cdot 0.031746}{2 \cdot 0.8532}} = 0.24175$$

2nd line pair:

$$Z_0 \cdot J_2 = \frac{\pi \cdot \Delta}{2 \cdot \sqrt{g_1 \cdot g_2}} = \frac{\pi \cdot 0.031746}{2 \cdot \sqrt{0.8523 \cdot 1.1038}} = 0.05138$$

3rd line pair:

$$Z_0 \cdot J_3 = \frac{\pi \cdot \Delta}{2 \cdot \sqrt{g_2 \cdot g_3}} = \frac{\pi \cdot 0.031746}{2 \cdot \sqrt{1.1038 \cdot 0.8532}} = Z_0 \cdot J_2 = 0.05138$$

4th line pair:

$$Z_0 \cdot J_4 = \sqrt{\frac{\pi \cdot \Delta}{2 \cdot g_3 \cdot g_4}} = \sqrt{\frac{\pi \cdot 0.031746}{2 \cdot 0.8532 \cdot 1.00}} = Z_0 \cdot J_1 = 0.24175$$

4th step:

The EVEN and ODD impedances of a line pair are generally specified in accordance with the following formulae:

$$Z_{EVEN} = 50\Omega \cdot \left[1 + Z_0 \cdot J_N + (Z_0 \cdot J_N)^2 \right]$$

$$Z_{ODD} = 50\Omega \cdot \left[1 - Z_0 \cdot J_N + (Z_0 \cdot J_N)^2 \right]$$

For the first and fourth line pairs we obtain:

$$Z_{EVEN} = 50\Omega \cdot \left[1 + 0.24175 + 0.24175^2 \right] = 65\Omega$$

$$Z_{ODD} = 50\Omega \cdot \left[1 - 0.24175 + 0.24175^2 \right] = 40.8\Omega$$

Microwave Projects

For the second and third line pairs the values are:

$$Z_{EVEN} = 50\Omega \cdot [1 + 0.05138 + 0.05138^2] = 52.7\Omega$$
$$Z_{ODD} = 50\Omega \cdot [1 - 0.05138 + 0.05138^2] = 47.56\Omega$$

Use of PUFF

Simulation of ideal circuit using PUFF

First start "PUFF" And load the SETUP file. Then press the "F4" key and enter the following values for the Rogers material R04003:

- thickness 0.032"
- impedance level $z_d = 50\Omega$,
- design frequency $f_d = 1575\text{MHz}$,
- dielectric constant $\epsilon_r = 3.38$
- board thickness $h = 0.813\text{mm}$.

The printed circuit boards size "s" should be 200mm, and 50mm. is a sufficient distance between the connections (Fig. 3).

Then move into field "F3" and successively enter there the data for the two coupled line pairs required. Please transfer them precisely as shown in Fig. 4!

Press the "F1" key to make the layout window appear (Fig. 5). And now please pay attention, first move the cursor as far to the left as you can. Then press the shift key for upper case lettering and keep pressing the "Cursor Left" key until you get to the desired location. Press "1" and port 1 is connected immediately.

F4 : BOARD	
zd	50.000 Ω
fd	1.575 GHz
er	3.380
h	0.813 mm
s	200.000 mm
c	50.000 mm
Tab	microstrip

Fig 3: PUFF starting parameters.

F3 : PARTS	
a c	65.00Ω40.80Ω90.0°
b c	52.70Ω47.56Ω90.0°
c	

Fig 4: PUFF data for successive line pairs.

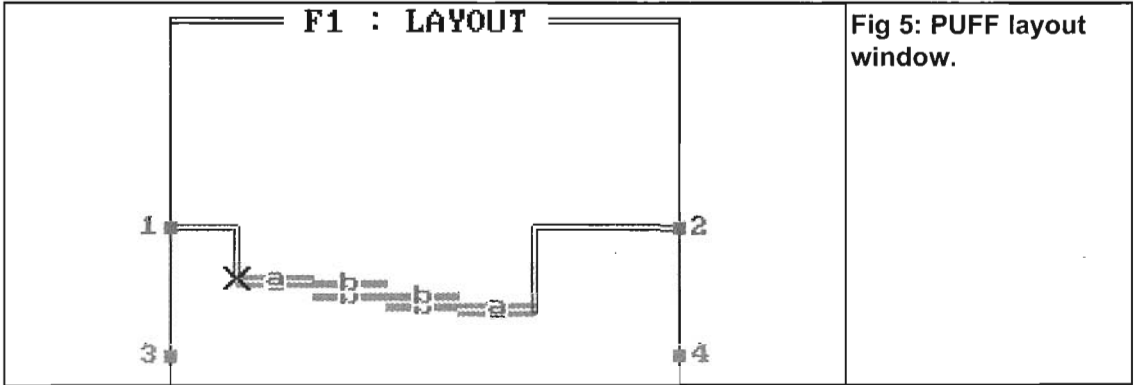

Fig 5: PUFF layout window.

Press letter "a" on the keyboard, followed by "Cursor Right". This positions the first line pair. Then press "b" and next "Cursor down", which connects up line pair "b".

Now press "Cursor down" again and the third pair is already sitting there on the screen. Finally press "a", "Cursor down" again and then "2" and port 2 is likewise connected to the exit of the circuit.

Use "F2" to go to the simulation window. Using "Cursor Up" or "Cursor Down", you can move, not just in the top left-hand "Plot window", but also along the axes of a diagram in the bottom right-hand corner ("linear plot") (Fig. 6).

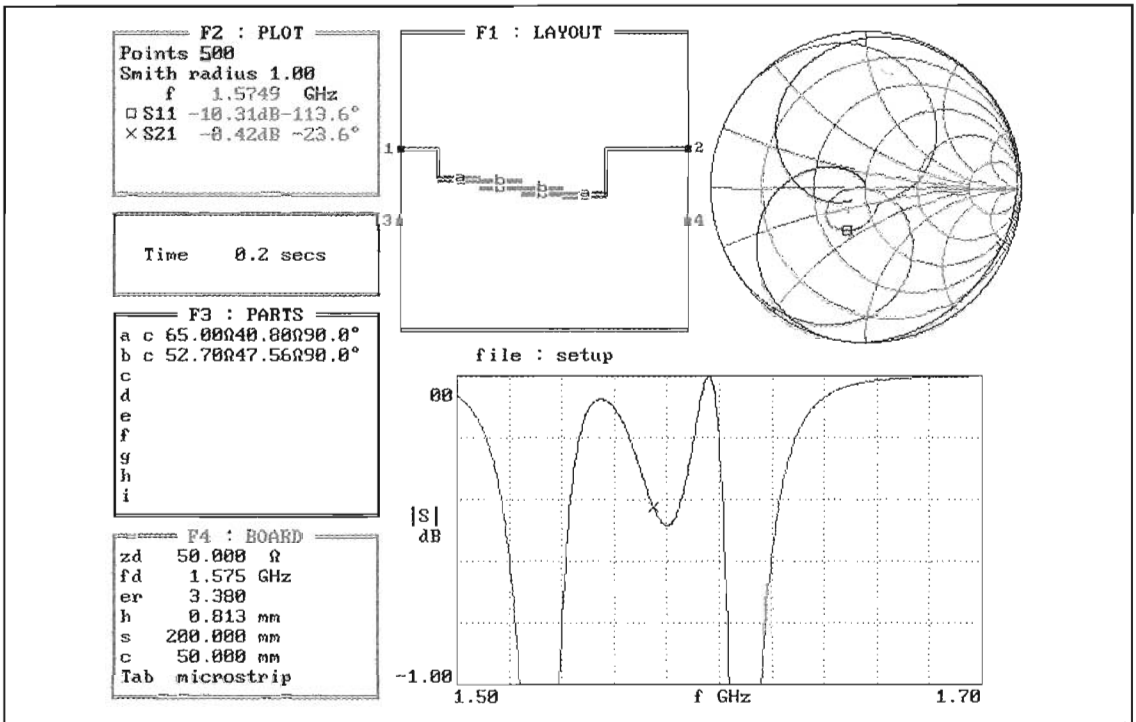

Fig 6: PUFF simulation window.

Microwave Projects

Here you pre-set, for example:

- 500 simulation points
- Smith radius = 1
- Representation of S11 and S22
- Horizontal scales in the ratio: 1.5 ...1.7GHz
- Vertical scales in the ratio: -1.00...0dB

And now please press “p”, and you can watch the computer at work. If you think thats too slow, press “Q”, and then all the calculations are done and the image is built up off screen, and things go considerably faster!

If you look at the result now, you'll undoubtedly be a little disappointed. It is nowhere near a ripple with maximum 0.0436dB. It is greater by more than a factor 10 with the value being 0.5dB. But don't worry, we can still get round that. We just need to make some very slight corrections to the line data!

We need only reduce the electrical length of the first and fourth line pairs (part “a” in the parts list) by approximately 1 degree and increase the design frequency by 2MHz in order to obtain the theoretical curve (Fig. 7)!

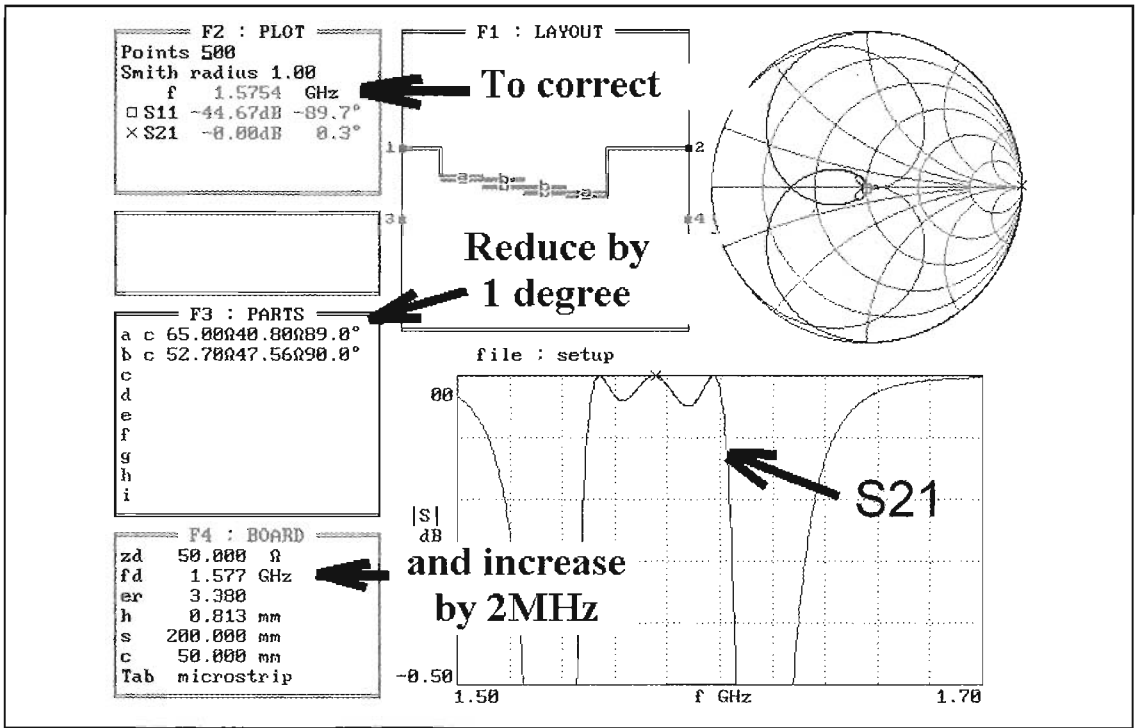

Fig 7: PUFF simulation after slight corrections.

Simulation of the real circuit with PUFF

First call up the "SETUP.PUF" file from the PUFF directory into a text editor and then enter the remaining printed circuit board data. Thickness of copper layer = 35 micrometres and surface roughness for a strip conductor polished until it gleams with grinding paste or scouring powder approximately 2 micrometres. Loss factor " l_t " of the board material R04003 at this frequency max. 0.001):

```

zd      50,000Ω {normalizing impedance. 0<zd}
fd      1.575GHz {design frequency. 0<fd}
er      3.380 {dielectric constant. er>0}
h       0.813mm {dielectric thickness. h>0}
s       200.000mm {circuit-board side length. s>0}
c       100.000mm {connector separation. c>=0}
r       0.010mm {circuit resolution, r>0, use Um for micrometres}
a       0.000mm {artwork width correction.}
mt      0.035mm {metal thickness, use Um for micrometres.}
sr      2.000μm {metal surface roughness, use Um for micrometres.}
lt      1.0E-0003 {dielectric loss tangent.}

```

The amended setup file is loaded back into PUFF and then the exclamation mark for each pair of coupled lines is entered in field "F3". This switches to "real modelling with all side effects" (Fig. 8).

If we now place the cursor in field "F3" on part "a" and enter the equals sign, the actual data of the coupled lines are immediately placed into the dialogue field (Fig. 9).

Now we have to keep changing the values entered under "a" until the data determined above are displayed in the dialogue field:

```

Ze      = 65Ω
Zo      = 40.8 Ω
l         = 89 degrees

```

<pre> ===== F3 : PARTS ===== a c!65.00Ω40.80Ω90.0° b c!52.70Ω47.56Ω90.0° </pre>	<pre> Ze: 65.006Ω Zo: 40.796Ω l : 89.032° </pre> <pre> ===== F3 : PARTS ===== a c!66.10Ω43.56Ω89.6° </pre>
<p>Fig 8: Exclamation mark changes to real modelling mode.</p>	<p>Fig 9: PUFF data for part "a".</p>

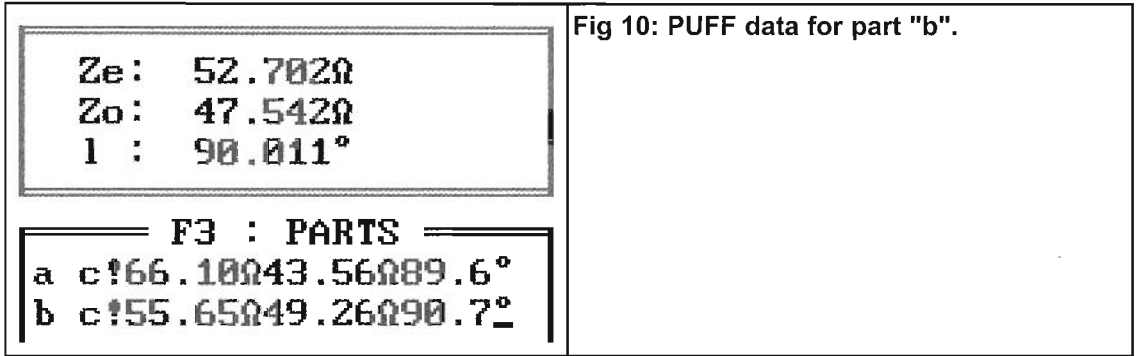

Fig 10: PUFF data for part "b".

It can be seen that to bring this about the entry for "a" has to be

$$c! 66.1\Omega 43.65\Omega 49.6^\circ$$

This procedure must be repeated for part "b" (Fig. 10). The target is to obtain this display in the dialogue field:

$$\begin{aligned} Z_e &= 52.7 \Omega \\ Z_o &= 47.56 \Omega \\ l &= 90 \text{ degrees} \end{aligned}$$

For this, finally, we need the entry:

$$c! 55.6\Omega 49.26\Omega 90.7^\circ$$

Fig. 11 shows the result of the circuit simulation if the losses are taken into account.

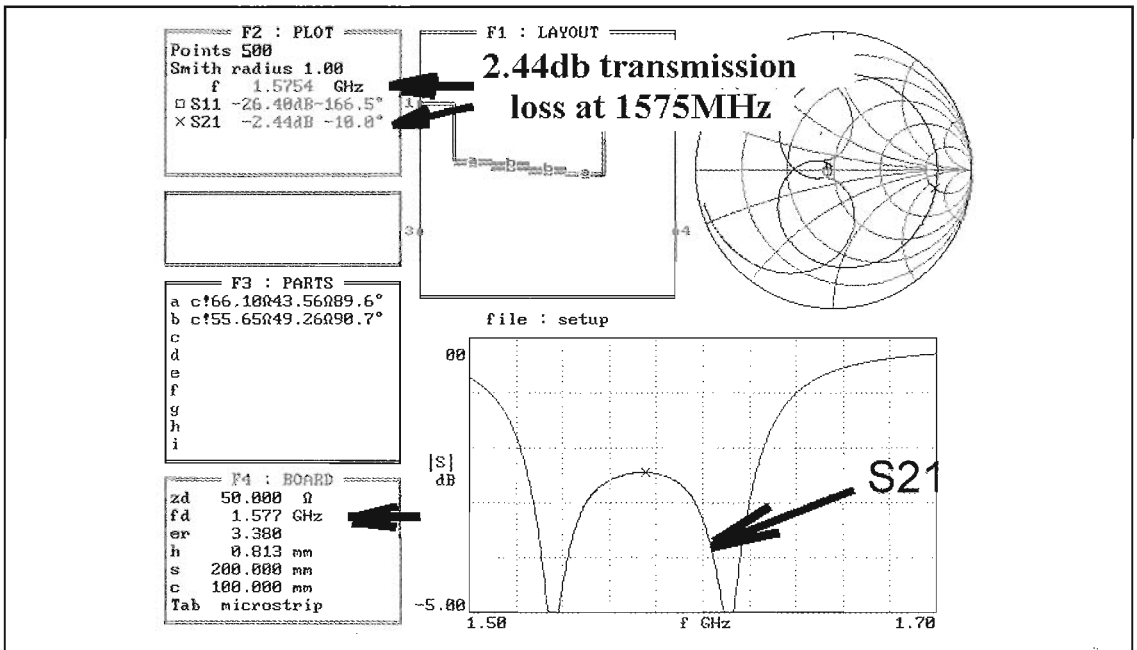
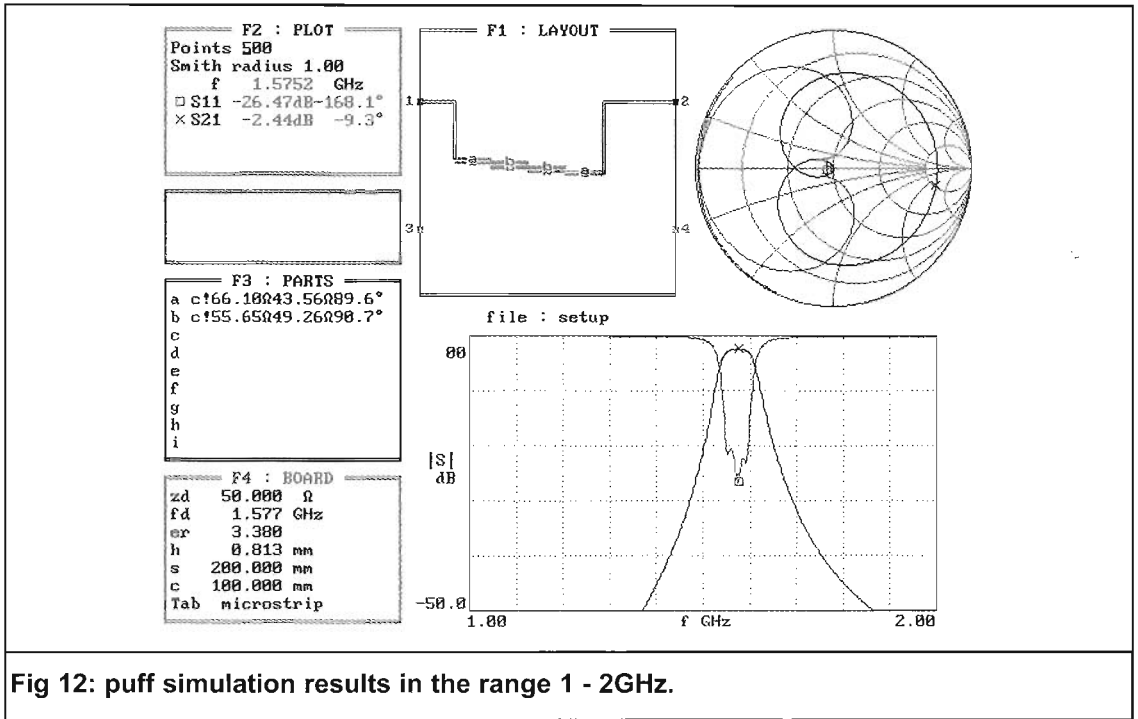

Fig 11:PUFF results with losses taken into account.



The design frequency continues to remain at 1577MHz, but following the simulation use "Page Down" to move the display cursor to 1575MHz. We now have a transmission loss of approximately 2.5dB.

If we correspondingly switch the value range in the two axes of the lower diagram, we can take another look at the long range selection, i.e. the behaviour in the range between 1 and 2GHz (Fig. 12).

Determination of mechanical, uncorrected line data with PUFF

In order to get at the dimensions of the coupled lines, we move back again into field "F3" and delete the exclamation mark for part "a" behind the letter "c" (for coupled lines). As soon as we key in the equals sign behind here, we obtain the desired values in the dialogue field (Fig. 13):

Length l = 29.34mm
 Width w = 1.59mm
 Gap s = 0.31mm

Repeat this for part "b", i.e. the two central pairs of coupled lines, and we correspondingly obtain Fig. 14:

Length l = 29.15mm
 Width w = 1.82mm
 Gap s = 1.84mm

<pre> l: 29.336mm w: 1.586mm s: 0.311mm </pre>	<pre> l: 29.151mm w: 1.819mm s: 1.835mm </pre>
<pre> F3 : PARTS a c 66.10Ω43.56Ω89.6° b c !55.65Ω49.26Ω90.7° </pre>	<pre> F3 : PARTS a c 66.10Ω43.56Ω89.6° b c 55.65Ω49.26Ω90.7° </pre>
<p>Fig 13: PUF results for line pair "a".</p>	<p>Fig 14: PUF results for line pair "b".</p>

Then, as a preliminary to the board design, determine the width of the 50Ω feed likewise in the same way. It is modelled as "lossy transmission line with 90 degree length" and, as part "c", supplies a required width, w = 1.84mm, following the deletion of the exclamation mark (Fig 15).

Necessary layout corrections

Here we are dealing either with striplines open at the end or with the junction of two striplines that are of different widths. In both cases, the familiar open-end correction is required, due to fringing, but one peculiarity should be taken into account here at the open ends of coupled lines:

The two line pairs are coupled to each other both electrically and magnetically. It is true that the electrical field lines project beyond the open ends of the striplines (so we need to do some shortening...), but the magnetic coupling decreases linearly in this area right down to zero.

For this reason, calculate in only *half* the "open-end-extension" which would otherwise be normal and shorten the line correspondingly!

Apart from this, we now need several tools to create the layout:

<pre> l: 28.936mm w: 1.842mm </pre> <pre> F3 : PARTS a c 66.10Ω43.56Ω89.6° b c 55.65Ω49.26Ω90.7° c t1 _50.73Ω 90° </pre>	<p>50 Ohm Feed</p> <p>file : setup</p>	<p>Fig 15:PUFF determining the width of the 50Ω line.</p>
--	---	---

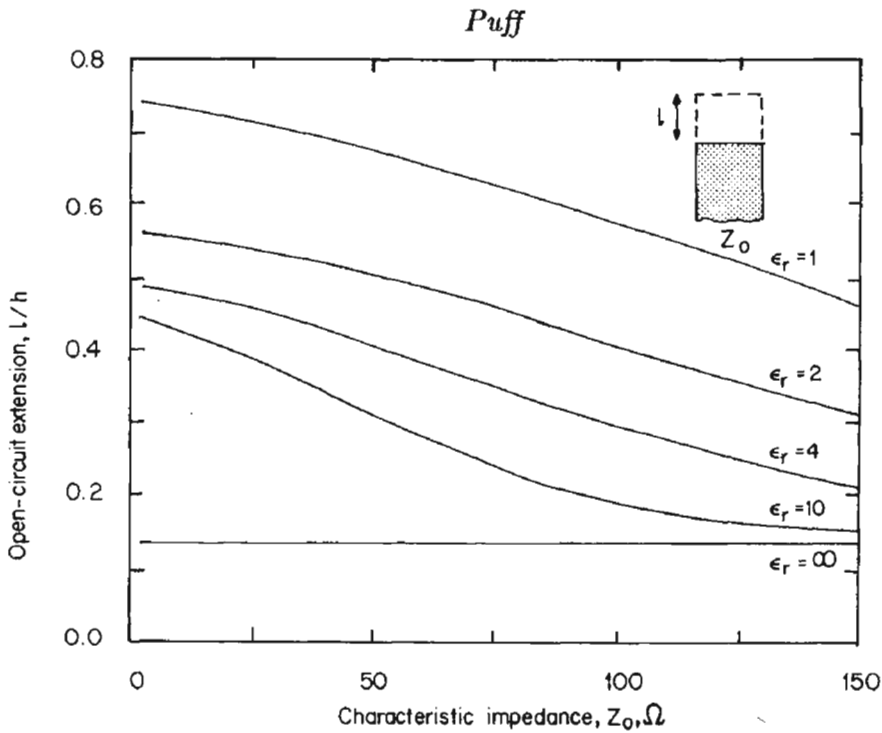

Figure 7.2 The open-circuit end correction in microstrip, plotted from (7.2). The artwork length correction in a parts list should be *negative*.

Fig 16: Diagram for determining the open end extension of striplines, from PUFF manual.

- The tried and trusted diagram for determining the open-end-extension from the PUFF manual (Fig. 16).
- A simple hand drawn sketch (Fig. 17) with the electrical data of the individual line pairs already determined. Enter the necessary corrections.
- A printed circuit board CAD program, which simultaneously makes it possible to solve tricky construction problems (e.g. GEDDY-CAD, tried and trusted for such microwave tasks for many years).

1st step:

The first and fourth line pairs consist of two striplines each with a width of 1.59mm. With the help of PUFF we obtain the impedance level for the pre-set printed circuit board data:

The result gives us: $Z = 54.6\Omega$

So we go to the above diagram from the PUFF manual. For this task, it supplies (with $\epsilon_r = 3.38$) an open-end extension $\Delta l/h$ of approximately 0.45. So these section pieces must be reduced by

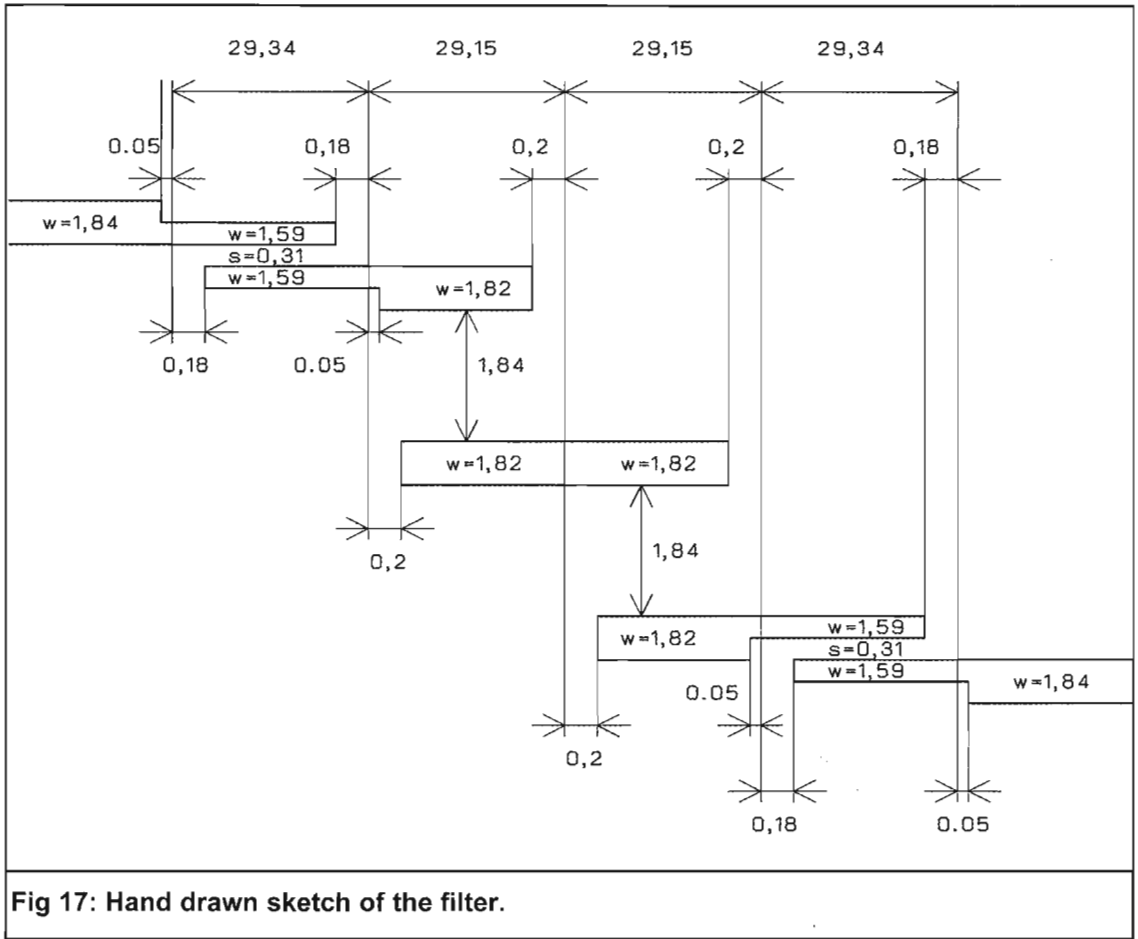

half of $0.45 \times 0.813\text{mm} = 0.18\text{mm}$ at all open ends!

2nd step:

At the start and end of the bandpass, the 50Ω feed is connected up with a width of 1.84mm and turns into the (narrower!) stripline with a width of 1.59mm. So the narrower line must be extended by a little piece measuring $(1.59\text{mm}/1.84\text{mm}) \times 0.45 \times 0.813\text{mm} = 0.05\text{mm}$.

3rd step:

The two central line pairs have conductor widths of 1.82mm. The associated impedance level (according to PUFF) is 50.4Ω and at $\epsilon_r = 3.38$ requires an open-end correction of $0.48 \times 0.813\text{mm} = 0.39\text{mm}$.

Again, only half of this value, i.e. approximately 0.2mm, needs to be cut off from the two ends.

4th step:

When the first line pair meets the second and the third meets the fourth, there is a correction of $(1.59\text{mm} / 1.82\text{mm}) \times 0.48 \times 0.813\text{mm} = 0.05\text{mm}$.

The wider line must be shortened and the narrower line must be lengthened by this amount.

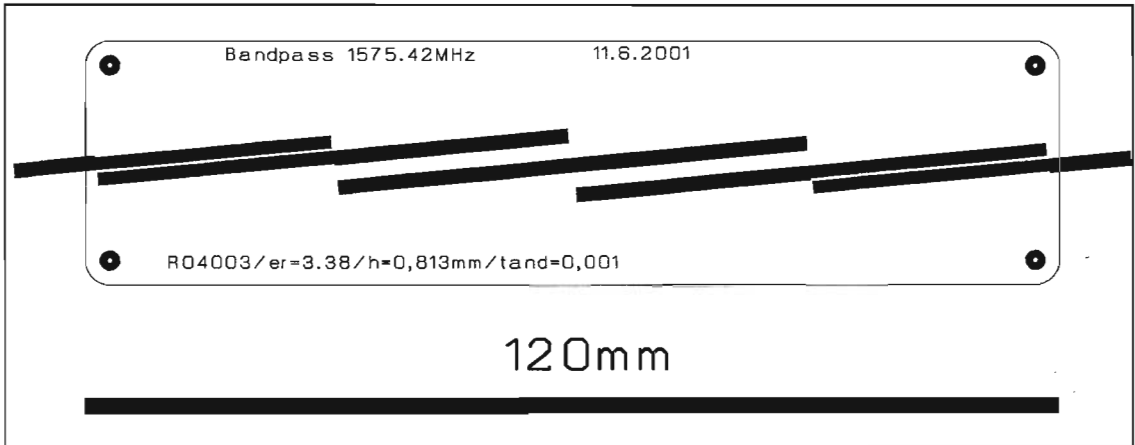

Fig 18: The completed layout using PUFF.

You should never omit entering all these details on a sketch because of laziness. It is an obligatory stage in the layout design (Fig. 17) and you need to take considerable trouble just to produce the drawing. But this is as nothing in comparison with the time and expense which will be wasted if the behaviour of the prototype produced inexplicably displays big differences from the simulation and you have to laboriously check every individual dimension on the completed printed circuit board. Its really very annoying if a gross error in the board layout turns out to be the reason for this.

Normally if you've followed all the instructions in this article the divergences between the simulation and prototype are max. 1 - 2%.

The finished layout is designed to fit into a milled aluminium trough with internal dimensions of 30 x 120mm, as shown in Fig. 18.

One more tip for those who don't know why there is a thick 120mm long line under the printed circuit board. We need this to set up the board manufacturing equipment, unless there is a photo plotter available that can be used to photographically set the correct dimension. This is the only way we can find the correct scale and be able to handle the manufacturing problem posed by the narrow gap between line pairs 1 and 4.

Use of TRL85 Stripline Calculator

To determine the data for fitting the circuit into a screened housing, the "TRL85" stripline calculator from Ansoft is used.

Ansoft are known for supplying very high quality and expensive RF CAD programs, but have also always had their eye on instruction and training! So on their Homepage on the Internet [3] we find a student version of the microwave CAD package "Serenade" which can be downloaded free.

Following installation a very good stripline calculator called "TRL85.EXE" together with excellent

Microwave Projects

online help is in a separate directory. It can be used separately at any time or copied and transferred to other computers. You will very soon learn to appreciate its WINDOWS user interface.

If we now compare the simulation results from "TRL85" with the values from PUFF, we can make the following statements:

In normal cases, the data determined by PUFF and TRL85 for single and coupled striplines are practically identical.

In addition to this, TRL85 offers the advantage that screening can be brought into the simulation in the form of the "Cover Height" (the distance between the cover and the board).

With TRL85 all data which is of interest (impedance level, losses, broken down into dielectric loss, conductor loss and total loss... etc.) can be determined directly for a specific design frequency. Unfortunately, PUFF cant provide this in the same way, although you have to carry out calculations using these values, they are not displayed.

The "TRL85" program was described in a separate article by the same author and is the next article in this chapter.

Table 1 below shows the differences produced by TRL85 microstrip simulations for operation without and with screening.

Another tip:

TRL85, unfortunately, won't automatically apply the open-end correction either. So again we have to revert to the use of the diagram from the PUFF manual when a line end is open.

Table 1: TRL85 simulations with and without screening.

Bandpass Specification	TRL85 witout screening	TRL85 with screening distance = 13mm
50Ω Microstrip	Width = 1.84mm	Width = 1.84mm
First line pair:		
E = 89	Ladder width = 1.58321mm	Ladder width = 1.5769mm
1575.42MHz	Spacing = 0.33225mm	Spacing = 0.32877mm
$Z_e = 65\Omega$	Length = 29.2968mm	Length = 29.3133mm
$Z_0 = 40.8\Omega$		
Second line pair:		
E = 90	Ladder width = 1.8216mm	Ladder width = 1.81525mm
1575.42MHz	Spacing = 1.87272mm	Spacing = 1.82327mm
$Z_e = 52.7\Omega$	Length = 29.186mm	Length = 29.2009mm
$Z_0 = 47.56\Omega$		

Repetition of design using ANSOFT-SERENADE

Simulation of ideal electrical circuit

Since “SERENADE” is already installed on the PC, because “TRL85” stripline calculator has been loaded, we can repeat the design to see how our filter is simulated by this very modern program. Naturally, we are interested, above all, in what improvements it can give us, in terms of ease of operation or precision.

Procedure

Launch the SERENADE software and start a new project (e.g. “BP1575_1”).

Then look for the “ideal coupled line” (Fig. 19), position it on the screen four times (see preceding chapter!). In the “Property Editor”, enter the EVEN and ODD impedances, the electrical length of 90 degrees and the operating frequency of 1575.42MHz. When the component is positioned, the editor opens automatically. If it does not, just double click on the left hand mouse button on the circuit icon in the circuit diagram. Our ports are connected up at the input and output, but thats not enough yet!

The “Harmonica” circuit simulator is the problem, two of the four connections are open circuit for each coupled line pair and this is prohibited.

We could use a very high value resistance (e.g. 10M Ω) to such open connections. However unloaded ideal line sections (Stubs) are considerably better and have lower losses, with an electrical length of zero at 1575MHz and with an impedance $Z = 50\Omega$. They cause no additional losses, nor do they alter the data for the coupled lines.

Next the frequency block is reset and the range between 1GHz and 2GHz is represented in 1MHz steps. Rogers R04003 material is again used as substrate, with a thickness of only 32 MIL (0.813mm), as this gives the filter structure smaller dimensions. The other data are as follows:

Dielectric constant	$\epsilon_r = 3.38$
Metallisation Met1:	Copper with thickness 35 μm
Surface roughness	RGH = 2 μm
Loss factor	TAND 0.001

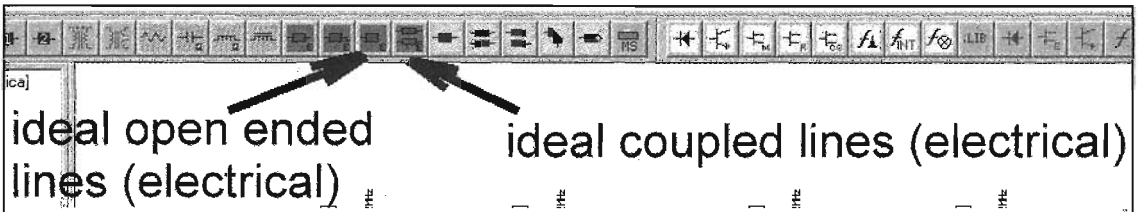

Fig 19: Serenade toolbar.

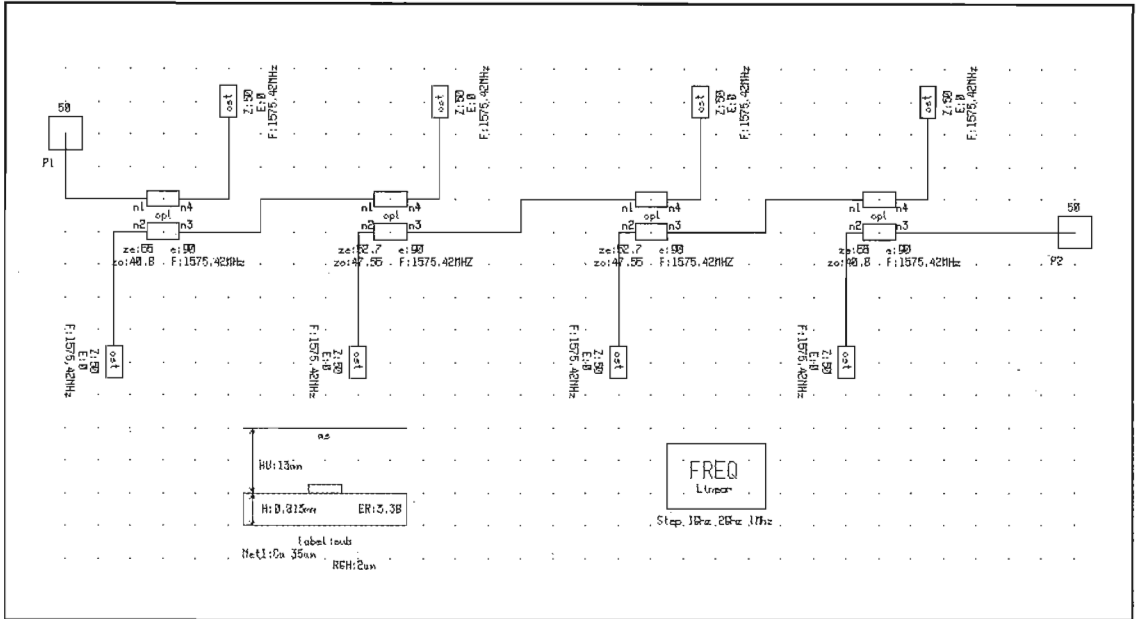

Fig 20: Circuit used for Serenade simulation.

The entire circuit, as used for simulation, is shown in Fig. 20. Even for those who don't know the program yet, the components just produced can be easily identified: Frequency and substrate control blocks certainly need no further explanation.

Following a precise check of the circuit, the simulation can begin (button with gears) and the Report Editor can be activated (turquoise / grey button). Select, for example, S11 and S21 in dB representation and examine the result (Fig. 21).

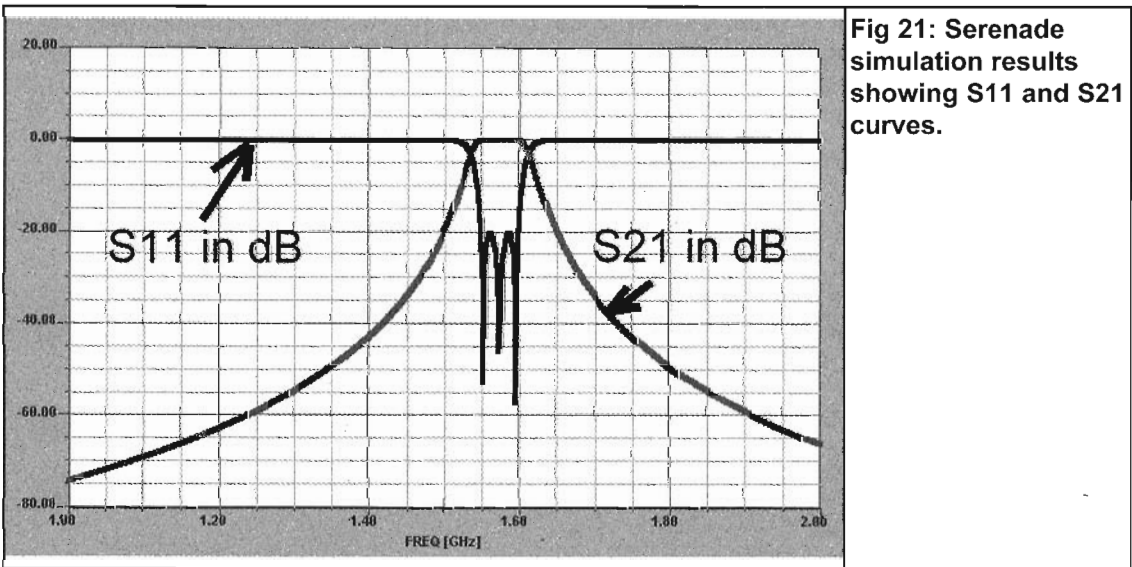

Fig 21: Serenade simulation results showing S11 and S21 curves.

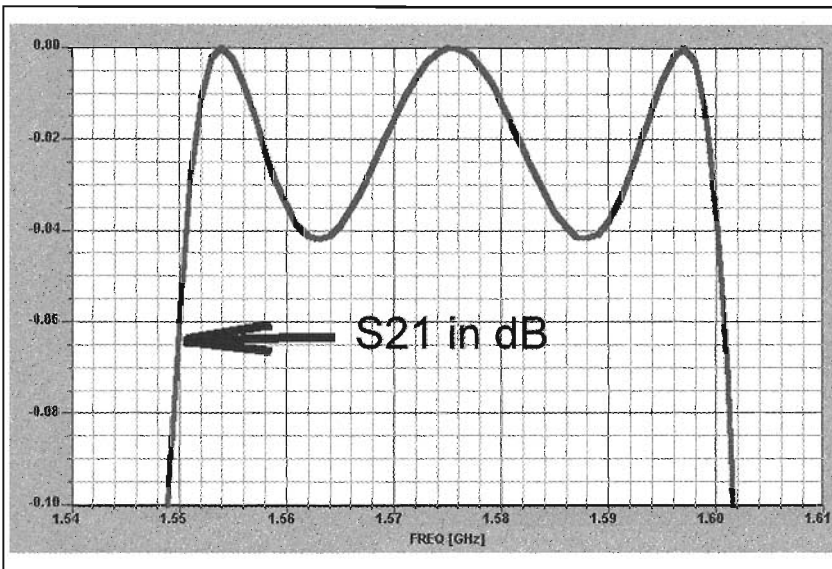

Fig 22: Serenade simulation results showing a closeup view of the S21 curve.

The result looks promising and S11 is never worse than the intended value in the pass band 20dB.

Use the right hand mouse button and click on “zoom in” repeatedly to bring out the precise sequence of S21 in the range from 0 to 0.1dB between 1550 and 1600MHz.

Only in this way can we assess whether the design technique from previous simulations really supplies the correct values desired.

Fig. 22 shows a perfect and well-formed filter curve.

In practice, both the mean frequency (1575MHz) and the minimum ripple value (0.041dB) are in accordance with the design requirements.

Simulation of physical circuit using HARMONICA

Apart from simulating the pass band with “electrical components”, HARMONICA also offers the option of a structure made up of “physical circuits”. This requires the conductor width, interaction gap and conductor length to be entered, the dimensional being in “mm”. These values can be obtained using the TRL85 stripline calculator, which can even be called up from the operating screen by pressing a button.

Here only the values for the first and fourth line pairs are needed, ($Z_e = 65 \Omega$, $Z_o = 40.8 \Omega$, $E = 90$ degrees). The track data is copper with $35\mu\text{m}$ thickness and a roughness of $2\mu\text{m}$ and the printed circuit board and housing data are board thickness $H = 0.813\text{mm}$, $ER = 3.38$, cover height above board, $HU = 13\text{mm}$, $TAND = 0.001$.

If you then press the “Synthesis” button, you obtain a representation corresponding to Fig. 23, thus:

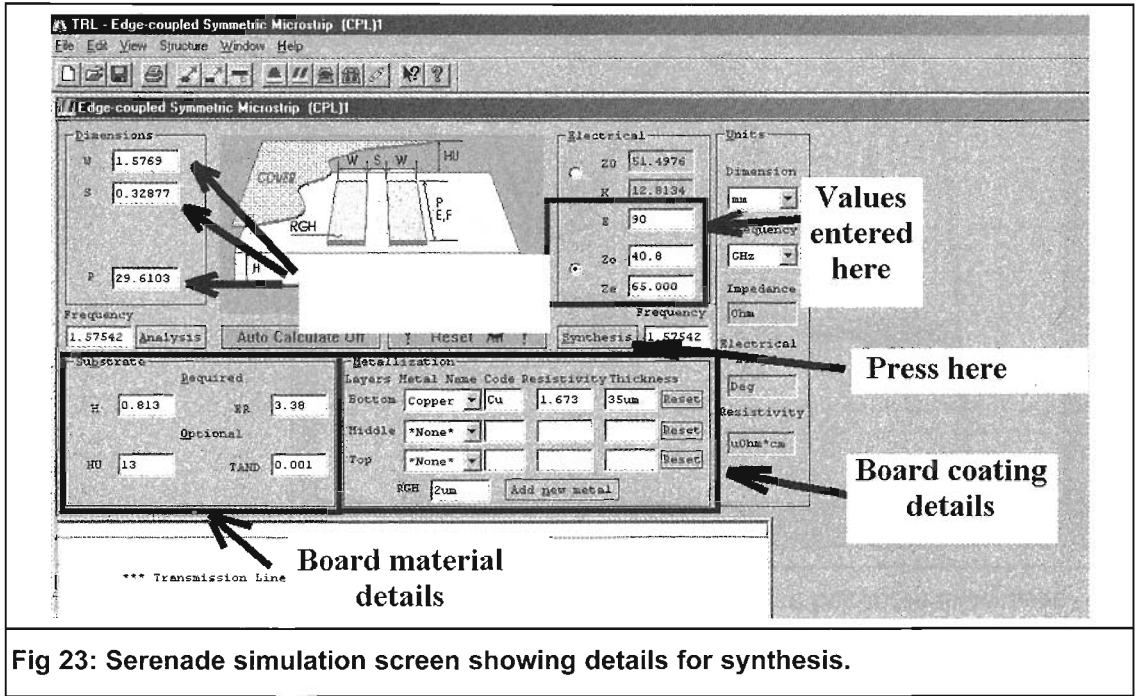

Fig 23: Serenade simulation screen showing details for synthesis.

Conductor width	W = 1.58mm
Interaction gap width	S = 0.33mm
Circuit length	P = 29.61mm

This procedure is repeated for the second and third line pairs ($Z_e = 52.7 \Omega$, $Z_o = 47.56 \Omega$, $E = 90$ degrees), then we obtain:

W = 1.82mm
S = 1.82mm
P = 29.20mm

It is interesting to compare this with PUFF, although it should be remembered that the part involving the housing and the distance of 13mm between the board and the cover is not included in this calculation!

Moreover, for simulation using PUFF, the electrical length for the first and last line pairs is presumed to be 89 degrees, whereas for SERENADE it is 90 degrees. The uncorrected PUFF values are as follows:

Line pairs 1 + 4:

W = 1.58mm
S = 0.31mm
P = 29.34mm

Line pairs 2 + 3:

W = 1.82mm
S = 1.84mm
P = 29.15mm

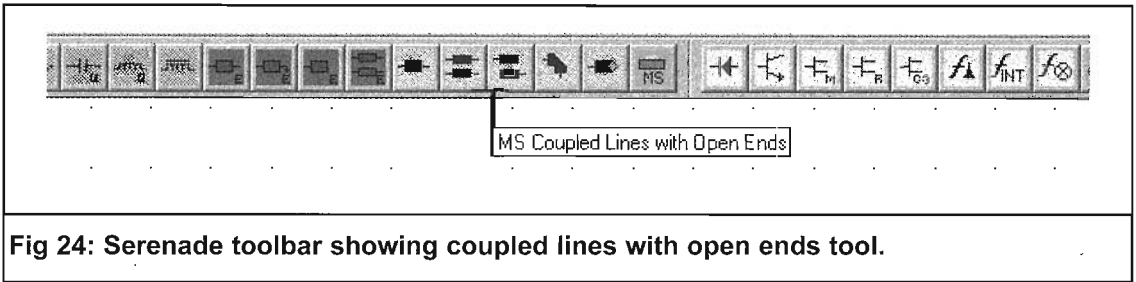

Fig 24: Serenade toolbar showing coupled lines with open ends tool.

It can be seen that the differences between the two simulations are not so devastating to make one of them seem completely unusable.

But let us simulate the pass band with the physical TRL85 values again, consider the result and ponder on:

- where the differences to the simulation using PUFF come from and
- how can we arrive at the correct values.

To do this, though, we must draw a new circuit diagram, and first we must delete the old one completely.

When we create the new circuit diagram, things move forward splendidly. The coupled line pair is actually there with the two open ends as a completed component (Fig. 24). This naturally makes the work considerably easier.

The screen is very tidy, even when the necessary data are entered (Fig. 25).

The S parameters after simulation using HARMONICA are shown in Fig. 26.

If we zoom into the representation of the pass band (Fig. 27), then several points strike us:

- The lowest transmission loss is predicted to be similar by both programmes (PUFF: approximately 2.5dB, HARMONICA approximately 2.8dB).

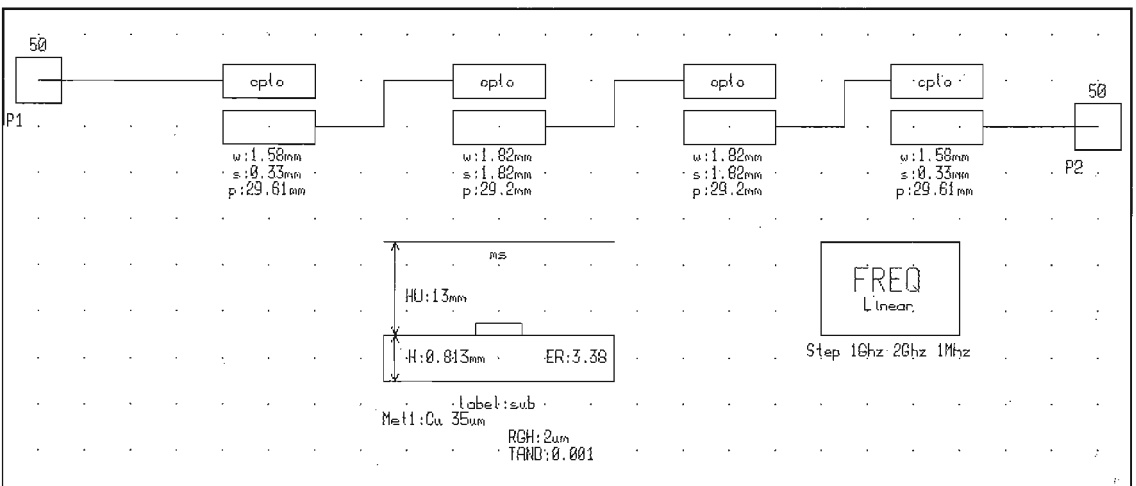

Fig 25: The revised circuit diagram for Serenade.

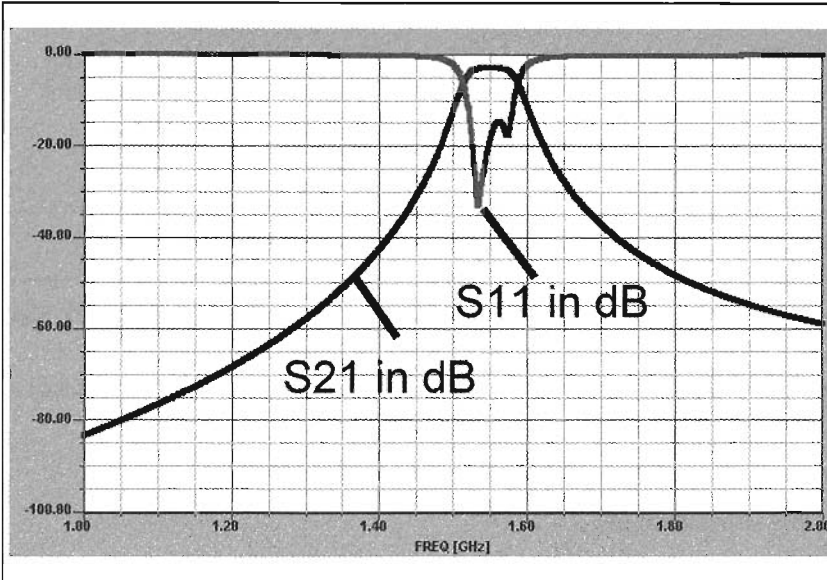

Fig 26: S Parameters from the Harmonica simulation.

- The mean frequency of the pass band according to the HARMONICA simulation reveals a divergence of 30MHz (approximately 2%) and is clearly too low. The program therefore does not make automatic open-end corrections!

Luckily, if we use Ansoft, we don't need to carry out the same changes to the diagram as listed in the PUFF manual to make corrections. Here we have something which is extremely useful.

What we actually do is to take specific values for the line pair through variables, pre-set maximum and minimum values for the S parameters at specific frequencies, and then let the optimiser do the job of reconciling.

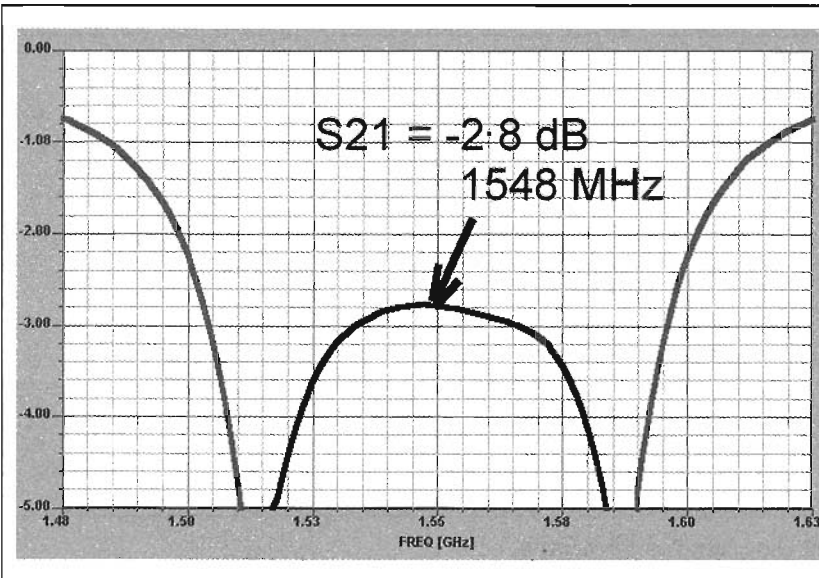
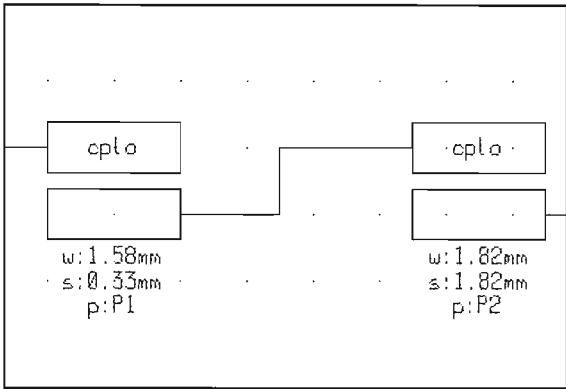
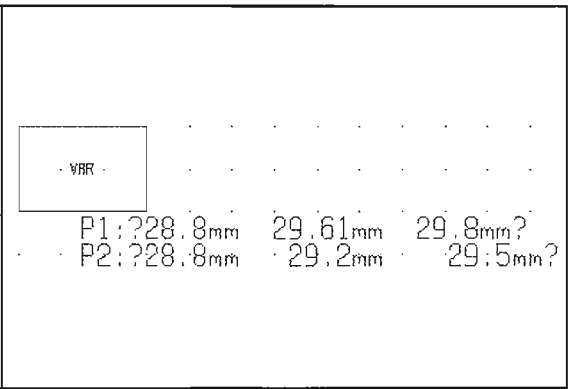

Fig 27: Closeup view of the S21 curve from the Harmonica simulation.

	
<p>Fig 28: Variables P1 and P2.</p>	<p>Fig 29: Entry of variable P1 and P2.</p>

Here we have the following steps:

1st step:

In the first and fourth line pairs, the physical length, P, is replaced by a variable, P1. We correspondingly use variable P2 for the second and third line pairs (Fig. 28).

2nd step:

Call up a “variable control block” (Menu path: “Parts/Control Blocks/Variables”) and enter the permissible variation range for P1 and P2 between question marks. In the middle is the original initial value (Fig. 29).

3rd step:

We now have to formulate the optimisation goals. There is an “original” button for this, in the form of a yellow and red practice target. In the student version a maximum of 3 optimisation goals are permissible, but this should just be enough at first.

The optimisation goals here are:

- In the “Frange1” range, from 1.55 to 1.6GHz, S21 should not fall below 3.3dB (Goal1)
- In the “Frange2” range, S11 should be lower than 20dB (Goal2) (Fig. 30).

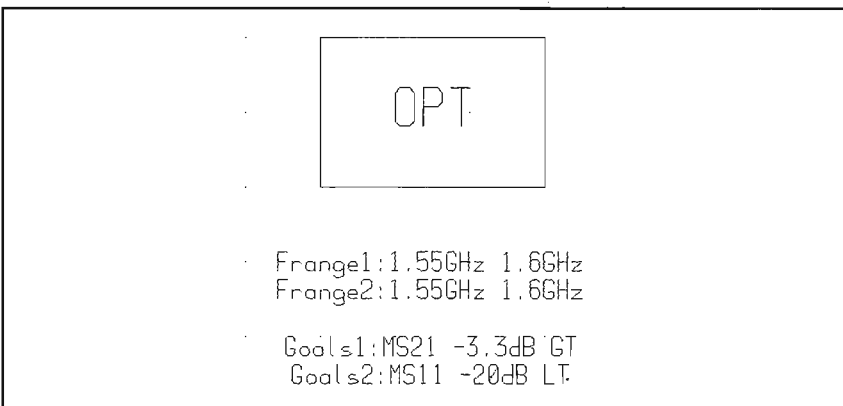
	<p>Fig 30: Goals for optimisation.</p>
--	---

Microwave Projects

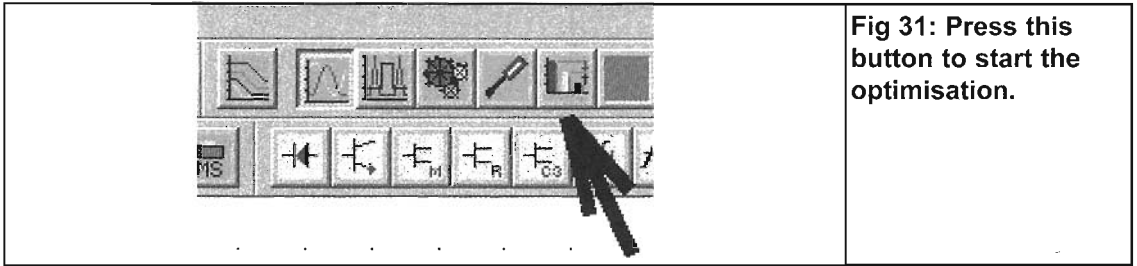

Fig 31: Press this button to start the optimisation.

4th step:

Now press the "Optimisation" button. The program normally indicates that it must first analyse the circuit, and asks for permission to do this. Grant it permission and also finally give it precise instructions on the number of optimisation searches, see Fig. 31.

5th step:

Please follow the sequence exactly:

- 1) Pre-set, for example, 2000 searches;

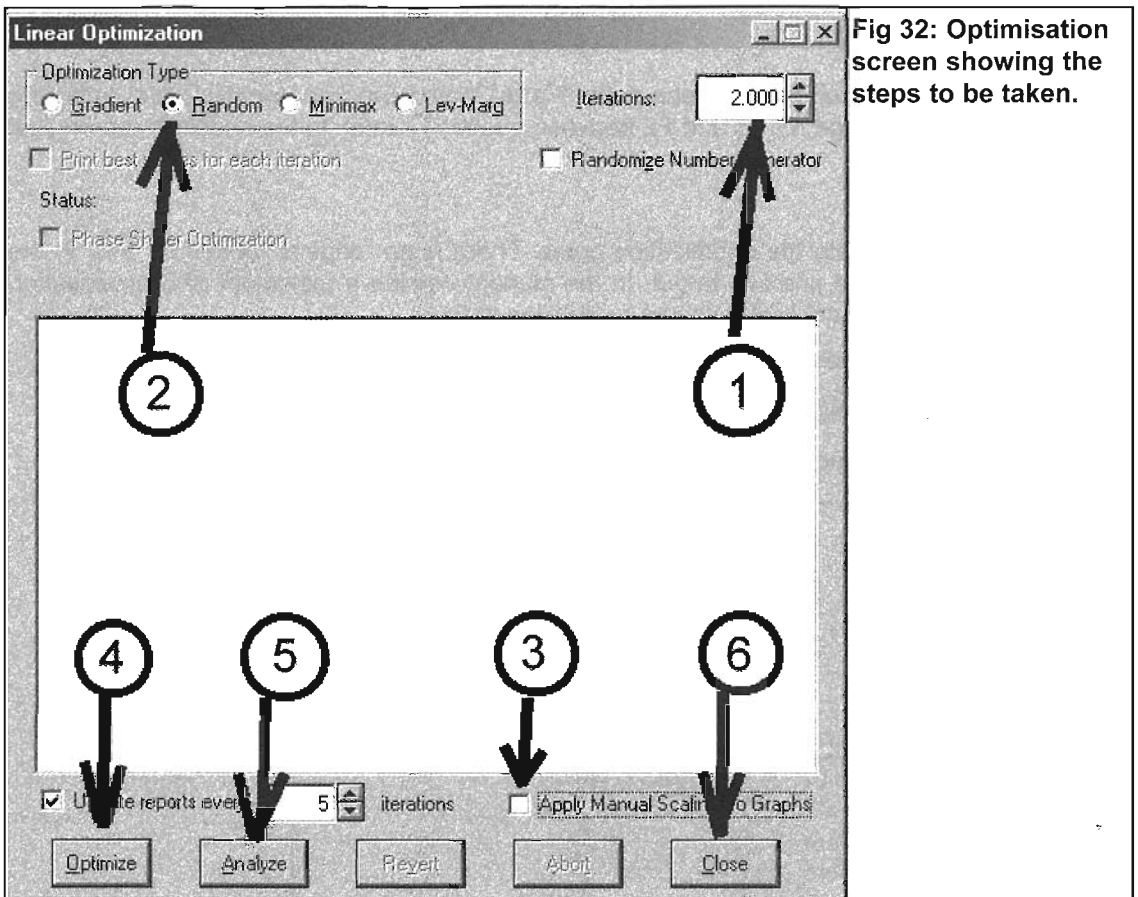

Fig 32: Optimisation screen showing the steps to be taken.

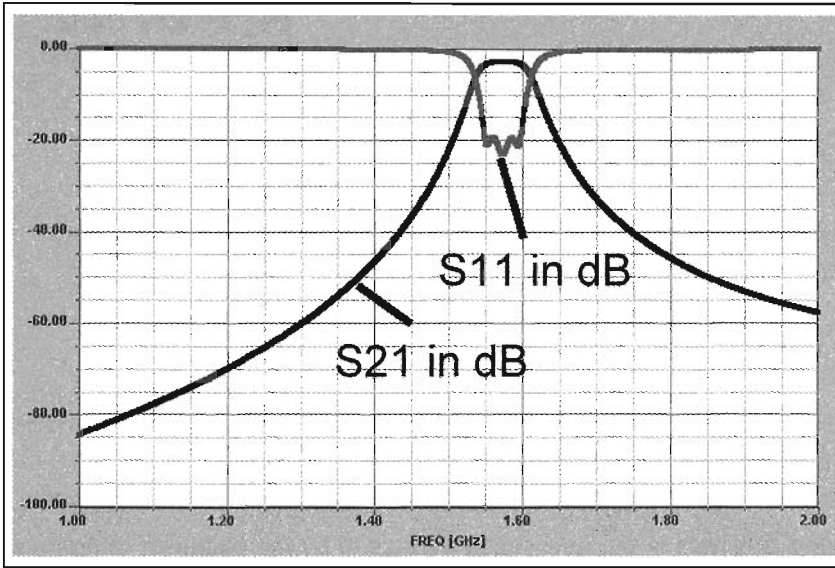

Fig 33: Results of optimisation.

- 2) Select "RANDOM" as optimisation type
- 3) Make sure this tick box is clear
- 4) Now press "Optimise" and wait until the program has found the best approximation to the conditions.
- 5) Now start another circuit analysis, as this is the only way to update the results diagram.
- 6) Now close this menu and obtain the diagrams with S11 and / or S21 in the foreground (Fig. 32).

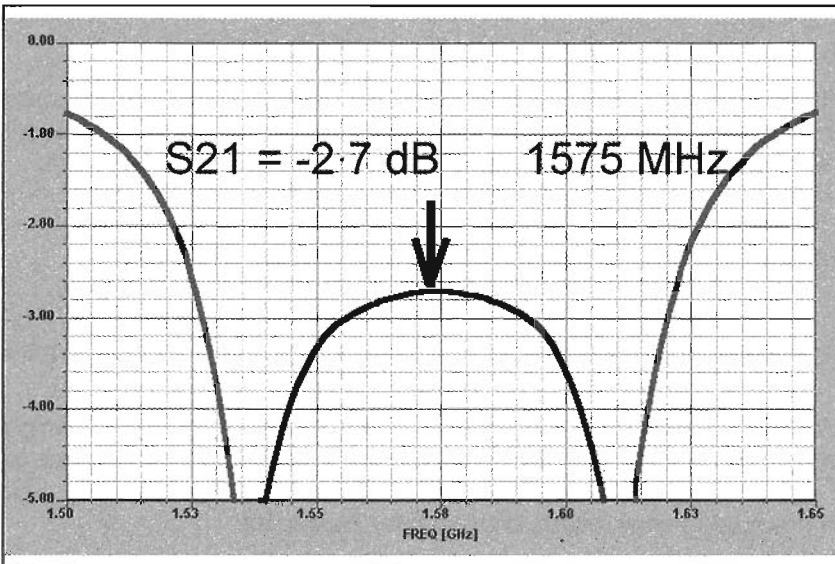

Fig 34: Closeup of the S21 curve after optimisation.

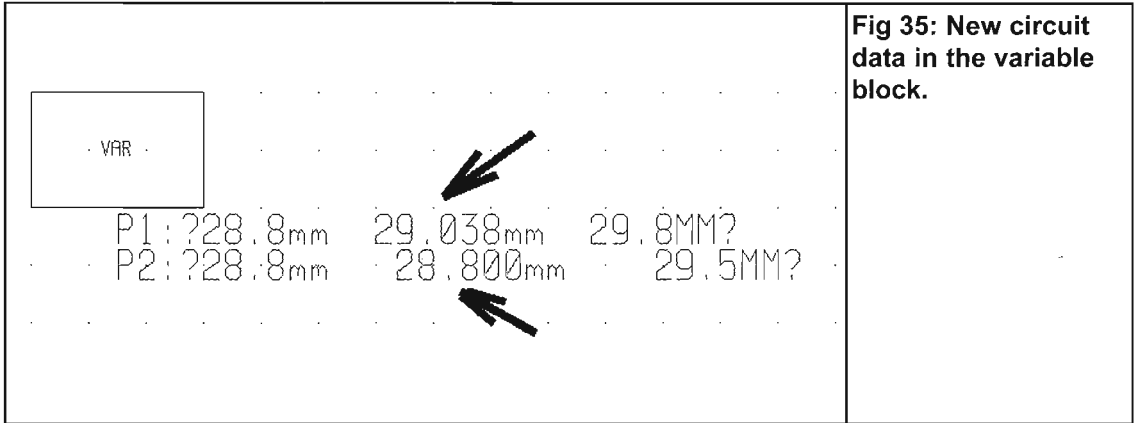

Fig 35: New circuit data in the variable block.

The results are shown in Fig. 33, and they look very satisfactory.

The data within the pass band have changed in accordance with Fig. 34; the result is useable.

The only question remaining is, where is the new circuit data used by the optimiser to produce the curves above?

It's very simple: you'll find them in the variable block instead of the initial values (Fig. 35)!

Finally, all data for the layout preparation in accordance with ANSOFT's physical variants:

First and fourth line pairs:

W = 1.58mm
S = 0.33mm
P = 29.04mm

Second and third line pairs:

W = 1.82mm
S = 1.82mm
P = 28.80mm

Now only one question remains: "Which of the two programs is really right"?

There's only one way to find the answer to this question: produce another printed circuit board using these dimensions, measure it under exactly the same conditions as for the PUFF product using the network analyser, and then cold-bloodedly analyse the results and compare them.

TRL85 microwave and analysis program, Gunthard Kraus, DG8GB

TRL85 is based on the same computing algorithms as PUFF or PCAAD, but is markedly more powerful.

Apart from the familiar WINDOWS tools, you will appreciate, for example, the option which allows you to take into account the incorporation of the circuit into a housing using "distance to cover". In addition, the relationships between losses and frequencies are carefully and separately logged, broken down into power losses and insulator losses, etc.

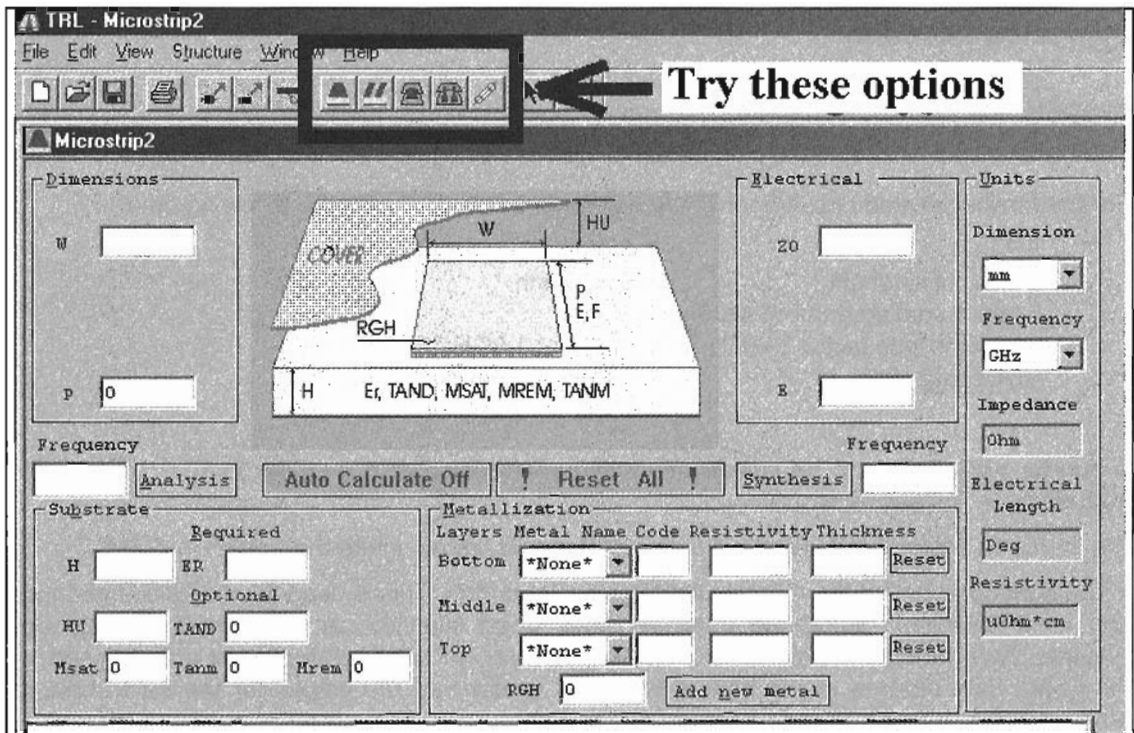

Fig 36: TRL85 screen display showing stripline calculation options.

Working with TRL85

The rest of this article assumes that a TRL85 is installed on the computer in use. You can set up a start button for the TRL85 program on the WINDOWS screen or simply move to the directory for TRL85 and click on the file "TRL85.exe".

On the first screen (Fig. 36) you should first click on each of the symbols in succession. In this way you can see the basic structure of the various modes of for yourself, together with the screen menus offered. The areas covered are:

- Microstrip
- Edge coupled Microstrip
- Stripline
- Edge coupled Stripline
- Coaxial cable

The following examples can be used to familiarise yourself with the program on a step-by-step basis.

Typical application

Analysis and synthesis of a 50Ω microstrip feeder

For the familiar printed circuit board material Rogers RO 4003 with the following data:

ER (ϵ_r)	= 3.38
Board thickness H	= 0.813 mm
Copper coating on both sides	= 35 μm
Dielectric loss factor TAND	= 0.001 at 1.6GHz
Screening plate	= 13 mm above the board

A quarter wave line is to be investigated, with an electrical length of 90 degrees at the GPS frequency $f = 1575.42\text{MHz}$.

We therefore select the "Microstrip" option button and first examine the screen in detail:

In the right hand half of the menu is the "Synthesis" button. This is used if a specific impedance and electrical circuit length (in degrees) have been selected, at the operating frequency required. As a result, the physical (mechanical) length and width of the circuit are obtained for the board data entered at the bottom left hand corner and the values for the track material entered at the bottom right hand corner.

In the left hand half of the menu is the "Analysis" button. This can be used to specify (from the mechanical dimensions) the electrical characteristics (the impedance level, the electrical length in degrees, the losses in dB / mm, even separated into dielectric and conductor losses, etc.).

The following steps should now be carefully carried out one after another (Fig. 37):

- 1) Enter a 50Ω impedance level here
- 2) Is the dimensional unit the mm?
- 3) Is the frequency already being measured in GHz?
- 4) Let the electrical length be 90 (the associated dimensional unit has already been set to degrees).
- 5) Enter frequency 1.57542GHz correctly.
- 6) The specifications for the track material [copper /thickness = 0.035mm /RGH = roughness = 5 μm] must go in this field. Under "Bottom" select the option "Copper" and for "RGH" enter the proposed 5 μm .
- 7) And here finally all data concerning the printed circuit board (thickness = 0.813mm / ER = 3.38 / cover distance from board = 13mm / TAND = 0.001)

When everything has been done, press the "Synthesis" button and the corresponding result appears on the screen (Fig. 38). In the top left hand corner of the menu, the two boxes for W (width) and P (physical length) are filled with the calculated values.

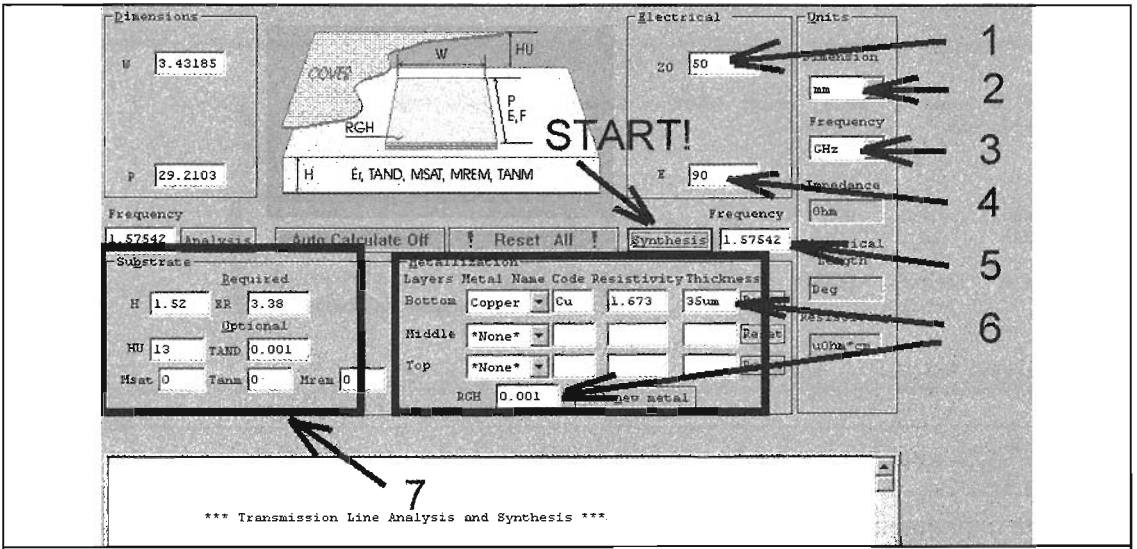

Fig 37: TRL85 steps for microstrip simulation.

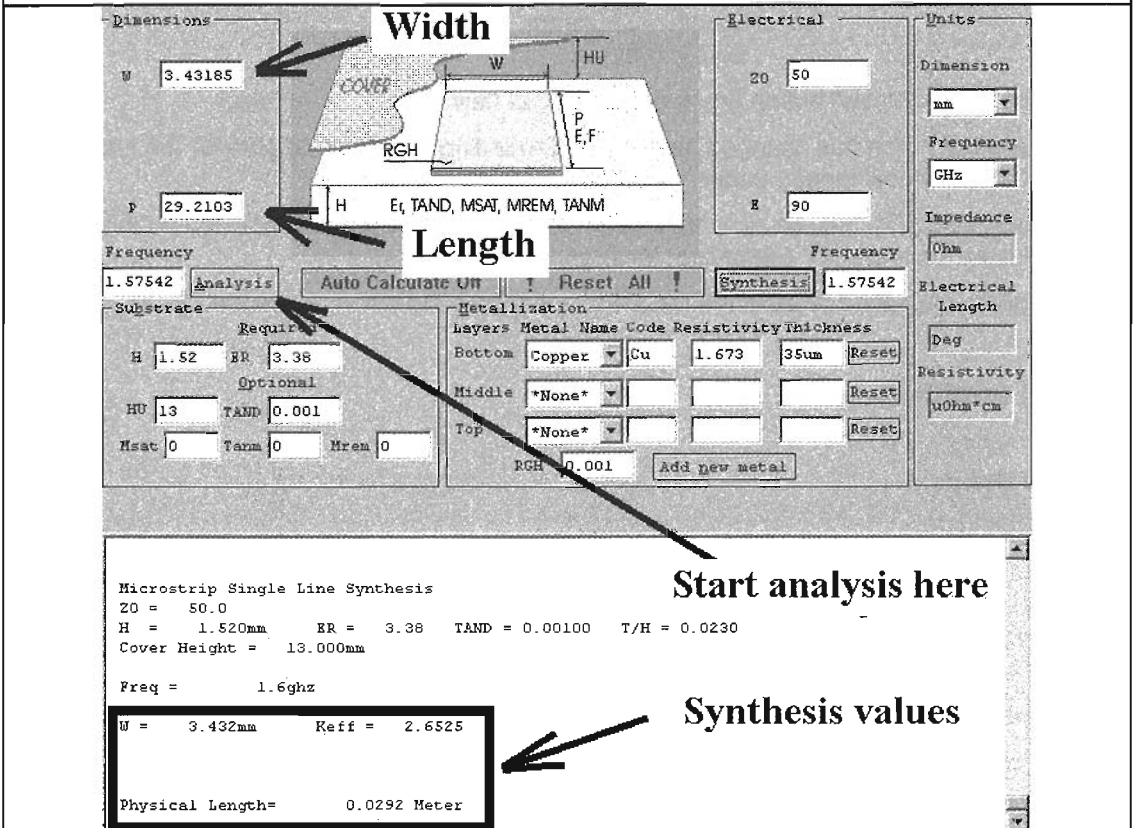

Fig 38: TRL85 results of synthesis on microstrip line.

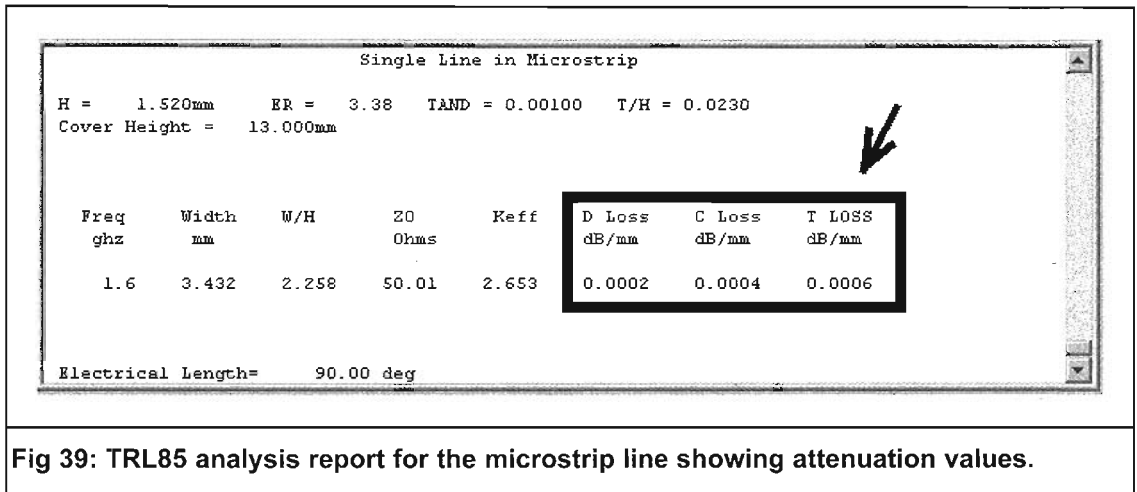

Fig 39: TRL85 analysis report for the microstrip line showing attenuation values.

Under the menu area, in a large separate field, the results are displayed. In the marked frame, here too we have the values for the length and width of the stripline, which are:

Width = 1.83mm
 Length = 29.24mm
 for Z = 50Ω

Now press the "Analysis" button again and see what new options are offered:

In the menu not much has changed, just that the rounding errors are shown for the impedance level and the electrical length, under "Reverse Calculation".

In the report field (Fig. 39), we now also have the attenuation value at 1.6GHz, and this divided into "D" (dielectric loss), "C" (conductor loss) and "T" (total loss).

You are given the option to save the results in a separate file when you leave TRL85.

Typical application:

Coupled line pair

With band pass filters made from coupled line pairs, once the filter design is complete we obtain the values for the EVEN and ODD impedances. They must first be converted into mechanical data before the printed circuit board is designed. "PUFF" can also do this but with "TRL85" we can also calculate fitting into a screed housing with the cover distance of, for example, 13mm.

The following data are assumed for the line pair in such a filter:

Z_{EVEN} = 65Ω
 Z_{ODD} = 40.8Ω
 Electrical length = 90 degrees

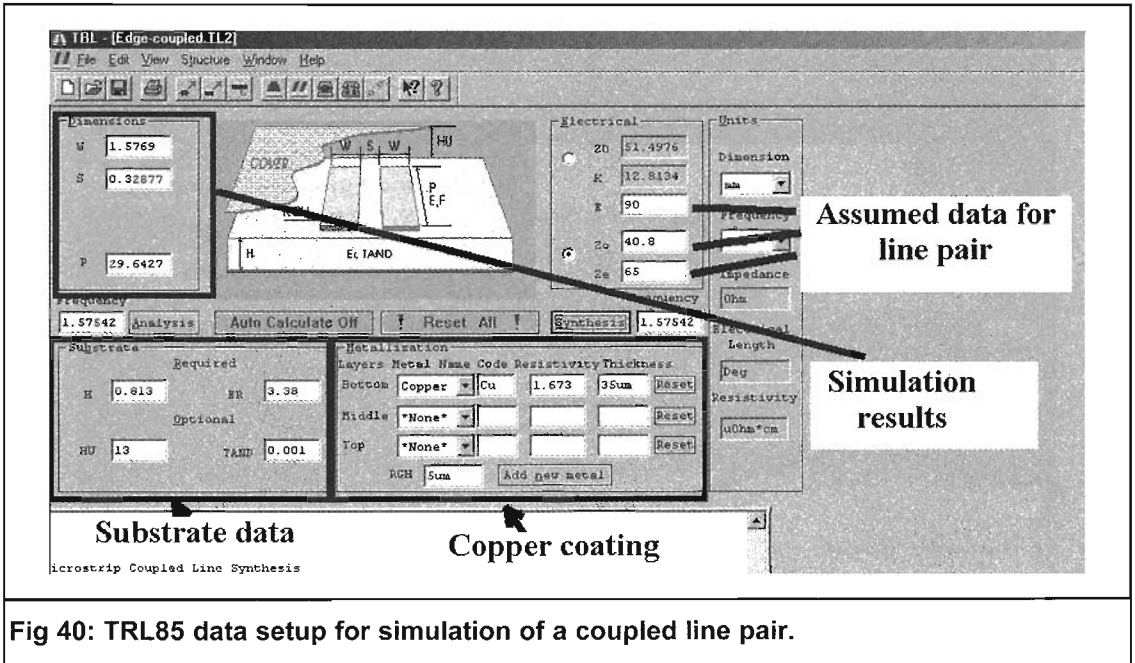

Fig 40: TRL85 data setup for simulation of a coupled line pair.

The same printed circuit board made of RO4003 is used again and the data to be entered for it are:

Relative permittivity	ER = 3.38
Printed circuit board thickness	H = 0.813mm
Copper coating on both sides	35 μ m
Dielectric loss factor	TAND = 0.001 at 1.6GHz
Screening plate 13mm above printed circuit board.	

Now use the second button from the left to switch to “edge coupled microstrip” and re-enter the printed circuit board data in the “Substrate” field in the screen menu that appears.

We also need the data on metallisation again. So we select “copper” under “Bottom” and for “RGH” we select a surface roughness of 5 μ m.

Now things get interesting, because we can now finally enter the electrical length, E, the ODD resistance, Z_o , and the EVEN resistance, Z_e .

Press the “Synthesis” button once, and we at once obtain the following values in the left-hand half of the screen (Fig. 40):

Conductor width	W = 1.58mm
Interaction gap	S = 0.33mm
Physical circuit length	P = 29.65mm

If we now press the “Analysis” button, we can see how TRL85 determines the electrical length, E, together with the resistances Z_o and Z_e . But the most important thing is the results report in the lower half of the screen, for there we find the precise loss factors and other details.

But don't forget that unfortunately TRL85 can not perform open-end corrections, we have to do

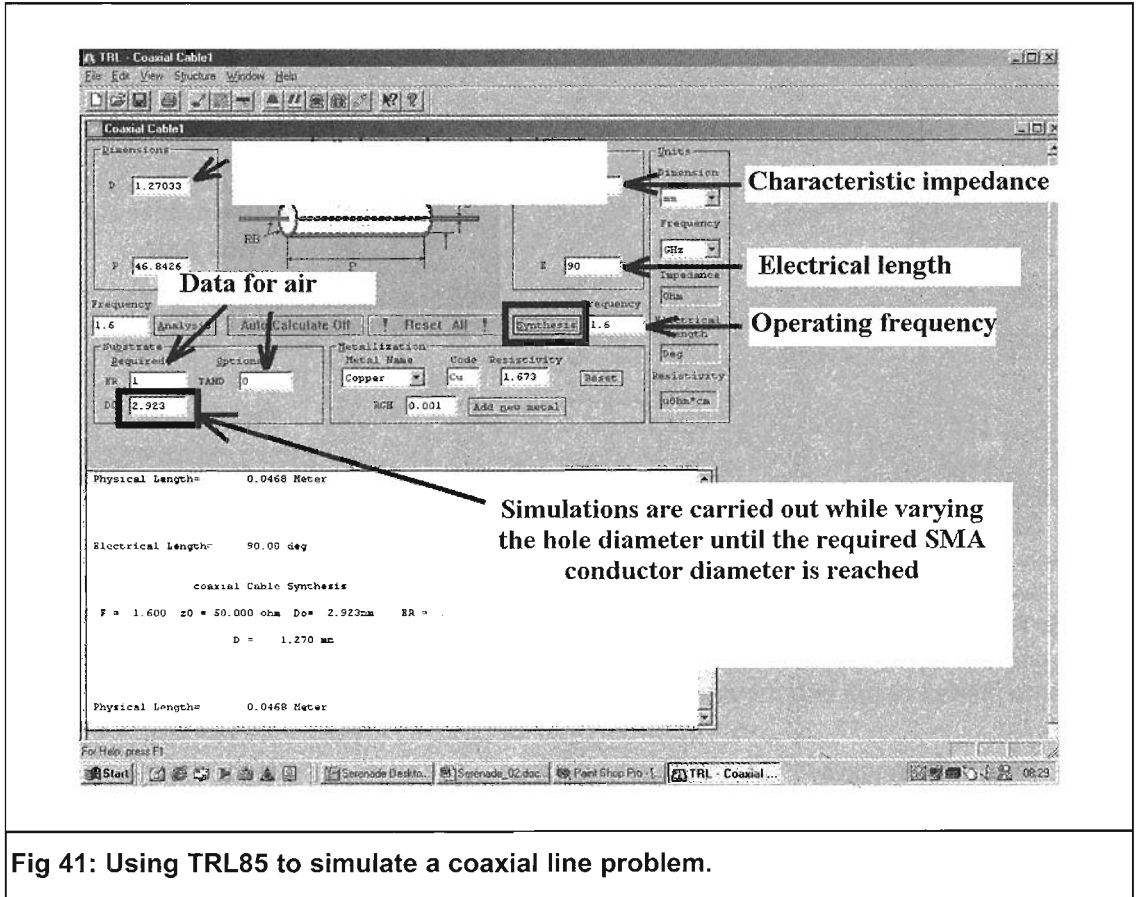

Fig 41: Using TRL85 to simulate a coaxial line problem.

that ourselves and determine the shortening required using, for example, the familiar diagrams in the “PUFF Manual”, see Fig 16.

Coaxial line

Here we are not trying to go over the data for a coaxial cable but to solve the following problem:

The internal conductor of an SMA flanged bush with a diameter of 1.27mm is fed through the wall of an aluminium housing to the printed circuit board. This housing wall is 3mm thick and the hole should be selected in such a way that the impedance level, even inside the wall, is 50Ω. What drill diameter should be selected? The solution is shown in Fig. 41.

Call up “TRL85”, select the “Coaxial cable” menu and enter an impedance level of 50Ω, an assumed electrical length of 90 (degrees), an operating frequency of 1.6GHz and the data for air (ER = 1, TAND = 0). The program then needs the external diameter and calculates the internal diameter for this. Here we can start with any value as the external diameter. Finally, press the “Synthesis” button.

We alter this external diameter and continue to create simulations until the internal diameter reaches the required value of 1.27mm. For this, we need a hole with a diameter of 2.9mm in the housing wall.

Summary

The “TRL85” stripline calculator provides an outstanding supplement to simulation using “PUFF” and is indispensable once the housing has to be included as well.

In other respects, “PUFF” and “TRL85” give practically identical results. Its ease of operation makes it a joy to use, and this is not the only way in which “PUFF” compares unfavourably. TRL85 also has direct modelling of all data (impedance level, splitting loss fractions, etc.) at the design frequency and a WINDOWS interface.

References

- [1] Design and realisation of microwave circuits, Gunthard Kraus, VHF Communications, from issue 4/96, P. 244 - 250, at irregular intervals to issue 2/99.
- [2] PUFF manual, original English version available from VHF Communications, <http://www.vhfcomm.co.uk>
- [3] Ansoft-Serenade manuals (supplied when program is downloaded), www.ansoft.com
- [4] APLAC manuals (supplied when program is downloaded), www.aplac.com
- [5] Microwave Engineering by David Pozar (John Wiley & Sons, New York, ISBN 0-471-17096-8).
- [6] Microwave Filters, Impedance-Matching Networks, and Coupling Structures by G. Matthaei, L. Young and E. M. T. Jones. (Artech House Publishers, ISBN 0-89006-099-1).
- [7] Microstrip Lines and Slotlines by K. C. Gupta, Ramesh Garg, Inder Bahl and Prakash Bhartia. (Artech House Publishers, ISBN 0-89006-766-X).
- [8] Software, manuals and tutorial are combined on an “ANSOFT-CD” and can be obtained from the author, provided the costs are reimbursed. Please E-mail me at: krausg@elektronikschule.de.

1

- 1.6GHz 97, 167, 172, 174-176
- 10GHz
 - conversion 47
 - operation 4, 59
 - specialists 2
 - transverter 28, 37, 46
- 1152MHz 39
- 1268MHz 34
- 13cm
 - amplifier 80, 85-86
 - band 69, 78, 96
 - GaAs Fet amplifier power 87
- 144MHz
 - transceiver 1, 4, 22, 24-26
 - transmitter 34

2

- 23cm
 - band 37
 - transverter 37-38

3

- 3456MHz transverter 68
- 3dB
 - compression 92
 - coupler 131-133
- 3GHz
 - oscillator 104
 - transverter 64

Microwave Projects

4

4-way

combiner	71	
Gysel combiner		71

47GHz

amplifier	91-92, 94	
microwave band		90
preamplifier	95	

5

5750MHz transverter	37	
---------------------	----	--

5905MHz Local Oscillator		62
--------------------------	--	----

5GHz

band	62	
divider	125	
Ham band	61	
pre-divider	121-124	
transverter	61, 65-67	

6

6.5MHz sub-carrier	34-35	
--------------------	-------	--

7

70cm band	106	
-----------	-----	--

9

9cm	96	
-----	----	--

A

Absorption material	95	
---------------------	----	--

ALPS model ED18-A	31	
-------------------	----	--

Aluminium nitride	93	
-------------------	----	--

Amateur bands	112	
---------------	-----	--

Amplifier		
chips	94	
circuit	80-81, 93	
Ansoft	144, 159, 166	
ANSOFT-CD	177	
Antenna		
changeover relay		76-78
matching	132	
port	113, 119	
AO-40	34	
ARRL UHF/Microwave Projects Manual	68	
Atmel	31-32, 36	
ATV transmitter	34	
Avantek power amplifier		62

B

Balanced		
mixer	34, 38-40, 61-62	
mixers	39, 41	
Bandpass		
filter	62-64, 148	
filters	105	
Bandwidth	6, 62, 72, 132, 148	
Bessel filter	146	
BFR34	44	
BFR520	44	
Bolometer principle	98	
Bond technology	90	
Boonton	105	
Butterworth filters	146	

Microwave Projects

C

CAD

- Program 96, 144, 157
- software 78, 80-81

Change-over relay 78

Chebyshev

- filters 146
- type 146-147

Coaxial

- cable 74, 171, 176
- Ceramic filters 47
- connector 100
- relay 45

Conversion loss 41, 62

Coupler 70, 72, 80, 105, 126-133, 145

Crystal oscillator 2, 29, 41

D

Demodulation of

- the CW 4
- SSB Signals 36

Demodulator 6, 10, 27

Design

- 3dB power dividers 125
- microwave circuits 143

Dielectric loss 45, 153, 160, 172, 174-175

Digital

- devices 134
- frequency divider 134
- meter 104
- signals 29

Direct Conversion Receiver 35

Directional	
coupler	105, 126-127, 130-131, 133, 145
couplers	97, 105, 125-127, 131

Doubly Balanced Mixer 38-39, 61-62

Down conversion 62

E

EMC 142

EME 37

ERA-2 64, 66

ERA3 34

F

Filter

 data 148

 design 174

 elements 46, 49, 52-53

 extensions 52

 type 148

Filtered second harmonic 34

Fm

 radio equipment 112

 receiver 112-113, 119

Frequency

 counter 20, 120, 135, 137, 141

 counters 121, 134-135

 meter 14, 25, 28

 multipliers 41, 105

 synthesiser 134

G

GaAs

 Fet amplifiers 88

Microwave Projects

MMIC	69, 88
Technology	69, 78, 96
Gali-2 MMIC	137, 141
GD	
meter	105-107, 109, 111-112
meters	105, 110-112
GPS	148, 172
Grid-Dip Meter	105
Gunnplexer	104

H

Hairpin filters	144
Half-duplex	
operation	76
system	77
systems	77
Harmonica	161, 163, 165-166
Heat conductive paste	101
Heatsink	69, 74-75, 89
Hilbert filters	6
Hittite prescalers	139, 141
Hybrid	
amplifier	88
ring	63-65
rings	64

I

IF	
attenuator	67
frequency	46-47, 62
port	41, 58-59
preamplifiers	47

Switching	62-63, 66-67
Input	
impedance	80, 113
matching	92
splitters	72
Insertion loss	43, 71, 126
Interdigital filter	42
ISM	
applications	88
band	34
Isolating network	71-72
J	
J-FET transistor	107
K	
K plugs	93
L	
L-band	29
LNA	59, 63-64, 68
LO	
amplifier	47, 49, 54-55, 59
filter	52, 54, 67
multiplier	59
Local oscillator modules	25
Logarithmic amplifier	14
Loop filter	31-32
Low-pass filter	116, 148
M	
M57762	
modules	72, 74
Power Amplifier modules	69

Microwave Projects

Masthead pre-amplifier	77
Matched directional coupler	127
Micro-controller	31-33
Microstrip	
couplers	125
line	173-174
lines	93, 177
technology	125
Microwave	
bands	1, 37
counters	135
Filters	177
frequencies	135
GAAS FET Amps	68
Mitsubishi	
GaAsFETs	79
model M67715	33
Mixer	6, 34, 37-41, 47, 49, 55, 57, 61-62, 67, 112, 132-133
Mixers	38-39, 41, 64, 68, 105, 125, 132, 140
MMIC amplifier	31, 45, 69, 88
Modifications of Qualcomm LNA Board	68
Modulation measurements	99
Modulator	6, 10, 28
Molecular resonances	91
MOSFET	39-40, 74

N

NBFM	37
Negative bias	60, 88-89, 109
Network analyser	104, 170
Noise	
FET	4
figure	45, 47

floor of the receiver	62
level	59, 113
Notch filter	116
NTC	
thermistor	98, 100-102, 104
thermistors	104
O	
Open-end	
correction	156, 158, 160
corrections	166, 175
Oscillator chain	41
Output combiners	72
P	
Pacific Monolithics	88
Parabolic antennas	10
Pass band ripple	146-147
Phase	
distortion	146
Locked Loop	1
Phasing-system SSB	35
PIC	14, 20, 28
PIN	
diode switch	63
diodes	45, 68
Pipecap filters	46
PLL	29, 31, 42, 46
PLLs	2
Polarisation	
of circular antennas	132
switching	132

Microwave Projects

Power

amplifier	10, 33, 62, 69-70, 77-78, 88, 90-91, 96
divider	64, 96
meter	72, 76, 97-98, 104, 141

Pre-amplifier 77-78

Pre-scaler 31, 46

Preamplifier 64, 78, 95

Prescaler ICs 137, 139

Prescalers 134-135, 139, 141

PUFF

CAD software	78, 80
manual	157, 160, 166, 176-177
simulation	150-152, 155

Push-pull mixers 125, 132

Q

Quadrature couplers 70

Quality of a mixer 38

Quartz

filter	4
filtering method	4

R

Receive

demodulators	10
filter elements	53

Reference frequency 31, 41

Reflection factor 146-148

RF

Circuit Design	68
connector	100
Design Guide	35
millivoltmeter	72

RO4003	175
Rogers	
material R04003	150
R04003 material	161
RSGB	89, 139
S	
S parameters	45, 92, 165-166
S-band	34
S-meter	1, 6, 14, 20, 24
S-parameters	80
S11	80, 147-148, 152, 162-163, 167, 169
S21 parameter	45
S22 parameter	95
Sage Laboratories Inc	126, 133
San Diego Microwave Group	46, 68
Semiconductor chips	90-91
Sequencer	63, 67, 76, 78
Sequencers	76
SERENADE software	161
SHF	
transverter	27
Weaver transceivers	6
Siemens Matsushita Components	142
Sinad meter	97, 112-113
SMD	
ICs	134
packages	44
Spectrum analyser	34, 59
SRA-11 mixer	47, 55
Stripline calculator	159, 161, 163, 177
Striplines	44, 145-146, 156-157, 160

Microwave Projects

Surface mount

construction techniques	88
device	88
devices	89

Surplus 5GHz bandpass filter	62
------------------------------	----

Synthesiser

calculations	46
VCO	46

T

T/R

relay	63, 67
relays	62

Teflon board	81
--------------	----

Thermistor	98-102, 104
------------	-------------

Thin-film technology	99
----------------------	----

Transceiver	1-2, 4, 6, 10, 20, 22, 24-27, 36, 46, 74-76
-------------	---

Transmission

lines	37, 39, 42, 70-72
loss	147, 155, 165

Transverter design	37, 61, 63
--------------------	------------

TRL85	177
-------	-----

TRL85 stripline calculator	159, 161, 163
----------------------------	---------------

Tuning stubs	49, 54, 57, 59
--------------	----------------

U

UHF/Microwave mixers	68
----------------------	----

Unbalanced mixer	39, 41
------------------	--------

V

Varicap

diode	14
diodes	106

VCO frequency	57
Velocity factor	65-66
Virtual ground	72
VSWR of antennas	130
VXO	2, 14, 27

W

Waveguide	
effects	95
filters	144
Weaver Method of SSB-Generation DJ9BV	36

Wideband	
amplifier	133
amplifiers	104, 132
feed	131
mixer	61

Wilkinson	
divider	92
dividers	92
splitter	70, 72

Wireline	
coupler	131
designs	127

X

X Band Transverter	46-47
X-band	46, 97, 99, 105

